

Specification

(Reference)

Title: FIXED CARBON COMPOSITION RESISTORS

Style: RC1/4,1/2

RoHS COMPLIANCE ITEM

Product specification contained in this specification
are subject to change at any time without notice
If you have any questions or a Purchasing Specification for any quality
Agreement is necessary, please contact our sales staff.



釜屋電機株式會社
KAMAYA ELECTRIC CO., LTD.

Issue Dept.: Research & Development Department Hokkaido Research Center

1. Scope

1.1 This specification covers the detail requirements for fixed carbon composition resistors; rectangular type, style of RC1/2, 1/4.

1.2 Applicable documents

JIS C 5201-1: 1998, JIS C 5201-2: 1998, JIS C 5201-2-1: 1998
IEC60115-1: 1999, IEC60115-2: 1982, IEC60115-2-1: 1982

2. Classification

Type designation shall be the following form.

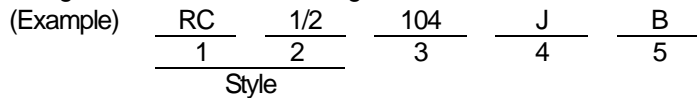

- 1 Fixed carbon composition resistors □ Style
- 2 Rated dissipation
- 3 Rated resistance Example; 104 → 100kΩ
- 4 Tolerance on rated resistance
- 5 Packaging form

3. Rating

3.1 The ratings shall be in accordance with Table-1.

Table-1

Style	Rated dissipation (W)	Rated resistance range (Ω)	Preferred number series for resistors	Tolerance on rated resistance
RC1/2	0.5	1~22M	E24	J(±5%)
			E12	K(±10%)
			E6	M(±20%)
RC1/4	0.25	1~5.6M	E24	J(±5%)
			E12	K(±10%)
			E6	M(±20%)

Style	Limiting element voltage (V)	Isolation voltage (V)	Category temperature range (°C)
RC1/2	350	500	-55~+125
RC1/4	250	100	

3.2 Climatic category

55/125/56

Lower category temperature - 55 °C
Upper category temperature +125 °C
Duration of the damp heat, steady state test 56days

3.3 Stability class

10%

Limits for change of resistance:
-for long-term tests ±(10%+0.5Ω)
-for short-term tests ±(2%+0.1Ω)

3.4 Derating

The derated values of dissipation at temperature in excess of 70 °C shall be as indicated by the following curve.

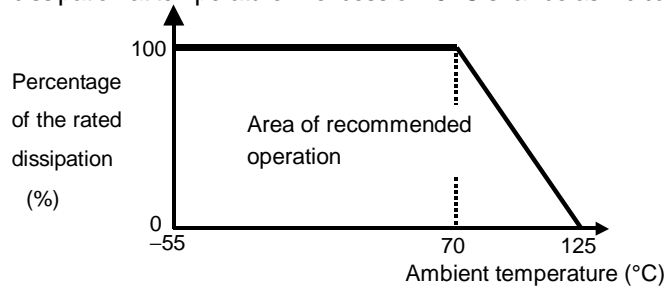

Figure-1 Derating curve

3.5 Rated voltage

d. c. or a. c. r. m. s. voltage calculated from the square root of the product of the rated resistance and the rated dissipation.

$$E = \sqrt{P \cdot R}$$

E : Rated voltage (V)
P : Rated dissipation (W)
R : Rated resistance (Ω)

Limiting element voltage can only be applied to resistors when the resistance value is equal to or higher than the critical resistance value.

At high value of resistance, the rated voltage may not be applicable.

4. Packaging form

The standard packaging form shall be in accordance with Table-2.

Table-2

Symbol	Packaging form		Standard packaging quantity / units	Application	Style
B	Bulk (Straight lead)	Loose package	500 pcs.	RC1/2	See 5.1
			1,000 pcs.	RC1/4	
H	* Horizontal forming		1,000 pcs.	RC1/4	See 8
			500 pcs.	RC1/2	
TB	52mm width taping box		2,000 pcs.	RC1/4, 1/2	See 9
TD	52mm width taping reel		3,000 pcs.	RC1/2	
			5,000 pcs.	RC1/4	

* The packaging form symbol of horizontal forming refer to Paragraph 8.

5. Dimensions

5.1 Straight lead type

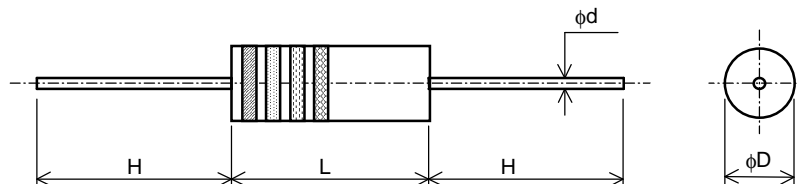

Figure-2

Table-3

Unit:mm

Style	L	φD	H	φd
RC1/2	9.5 ^{+0.8} / _{-0.7}	3.6 ± 0.2	28 ± 3	0.7 ^{+0.07} / _{-0.05}
RC1/4	6.3 ± 0.7	2.4 ± 0.1	30 ± 3	0.6 ± 0.05

6. Marking

6.1 Marking of product

The rated resistance and tolerance on rated resistance shall be marked by four color coding on the surface of resistor.
The color coding shall be based on JIS C 5062-1997 "Marking codes for resistors and capacitors".
The tolerance on rated resistance tolerance M($\pm 20\%$) shall be none color of the forth color code.

6.2 Marking of package

The label of a minimum package shall be legibly marked with follows;
(1) Classification (Style, Rated resistance, Tolerance on rated resistance, Packaging form) (2) Lot No. (3) Quantity
(4) Manufacturer's name or trade mark (5) Others

7. Performance

7.1 The standard condition for tests shall be in accordance with Sub-clause 4.2, JIS C 5201-1: 1998.

7.2 The performance shall be satisfied in Table-4.

Table-4(1)

No.	Test items	Condition of test (JIS C 5201-1)	Performance requirements
1	Visual examination	Sub-clause 4.4.1 Checked by visual examination.	As in 4.4.1 The marking shall be legible, as checked by visual examination.
2	Dimension Resistance	Sub-clause 4.4.2 Sub-clause 4.5	As specified in Table-3 of this specification. As in 4.5.2 The resistance value shall correspond with the rated resistance taking into account the specified tolerance.
3	Voltage proof	Sub-clause 4.7 Method: V-block method Test voltage: Alternating voltage with a peak value of 1.42 times the insulation voltage. Duration: 60 s \pm 5 s	No breakdown or flash over
4	Solderability Overload (in the mounted state)	Sub-clause 4.17 Without ageing Method: 1 (The solder bath method) Bath temperature: 235 °C \pm 5 °C Immersion time: 5 s \pm 0.5 s Depth immersion: A point within about 4mm from the resistor body Sub-clause 4.13 The applied voltage shall be 2.5 times the rated voltage or twice the limiting element voltage, whichever is the less severe. Duration: 5 s Visual examination Resistance	Good thinning as evidenced by free flowing of the solder with wetting of the terminations. No visible damage Legible marking $\Delta R \leq \pm (2\%+0.1\Omega)$

Table-4(2)

No	Test items	Condition of test (JIS C 5201-1)	Performance requirements
5	<p>Robustness of termination</p> <p>Tensile</p> <p>Bending</p> <p>Torsion</p> <p>Resistance to soldering heat</p>	<p>Sub-clause 4.16</p> <p>Sub-clause 4.16.2</p> <p>The force; 10N</p> <p>Duration: 10 s ± 1 s</p> <p>Sub-clause 4.16.3</p> <p>Method 1</p> <p>Bending times: 2 times</p> <p>Bending force: 5N</p> <p>Sub-clause 4.16.4</p> <p>Method A: Severity 2</p> <p>(two successive Rotations of 180°)</p> <p>Visual examination</p> <p>Resistance</p> <p>Sub-clause 4.18</p> <p>Method: 1B</p> <p>Solvent temperature: RC1/4: 300 °C ± 10 °C RC1/2:350 °C ± 10 °C</p> <p>Immersion time: 3.5 s ± 0.5 s</p> <p>Depth of immersion:A point within 4±0.8mm from the resistor body.</p> <p>Visual examination</p> <p>Resistance</p>	<p>No visible damage</p> <p>$\Delta R \leq \pm (2\%+0.1\Omega)$</p> <p>No visible damage</p> <p>Legible marking</p> <p>$\Delta R \leq \pm (3\%+0.1\Omega)$</p>
6	<p>Rapid change temperature</p> <p>Vibration</p>	<p>Sub-clause 4.19</p> <p>Lower category temperature: -55 °C</p> <p>Upper category temperature: +125 °C</p> <p>Duration of exposure at each temperature: 30 min.</p> <p>Number of cycles: 5 cycles.</p> <p>Visual examination</p> <p>Resistance</p> <p>Sub-clause 4.22</p> <p>Endurance by sweeping</p> <p>Frequency range: 10 Hz to 500 Hz</p> <p>Amplitude: 0.75 mm or acceleration 98 m/s² (whichever is the less severe)</p> <p>Total duration: 6 h</p> <p>Visual examination</p> <p>Resistance</p>	<p>No visible damage</p> <p>$\Delta R \leq \pm(2\%+0.1\Omega)$</p> <p>No visible damage</p> <p>$\Delta R \leq \pm(2\%+0.1\Omega)$</p>

Table-4(3)

No	Test items	Condition of test (JIS C 5201-1)	Performance requirements
7	<p>Climatic sequence</p> <p>-Dry heat</p> <p>-Damp heat, cycle (12+12hour cycle) First cycle</p> <p>-Cold</p> <p>-Low air pressure</p> <p>-Damp heat, cycle (12+12hour cycle) Remaining cycle</p> <p>-D.C. load</p>	<p>Sub-clause 4.23</p> <p>Sub-clause 4.23.2</p> <p>Test temperature: + 125 °C</p> <p>Duration: 16 h</p> <p>Sub-clause 4.23.3</p> <p>Test method: 2</p> <p>Test temperature: 55 °C</p> <p>[Severity(2)]</p> <p>Sub-clause 4.23.4</p> <p>Test temperature -55 °C</p> <p>Duration: 2h</p> <p>8 kPa</p> <p>Sub-clause 4.23.6</p> <p>Test method: 2</p> <p>Test temperature: 55 °C</p> <p>[Severity (2)]</p> <p>Number of cycles: 5 cycles</p> <p>Sub-clause 4.23.7</p> <p>The applied voltage shall be the rated voltage or the limiting element voltage whichever is the smaller.</p> <p>Duration: 1 min.</p> <p>Visual examination</p> <p>Resistance</p> <p>Insulation resistance</p>	<p>No visible damage</p> <p>Legible marking</p> <p>$\Delta R \leq \pm (10\%+0.5\Omega)$</p> <p>$R \geq 100 M\Omega$</p>
8	<p>Endurance at 70 °C</p>	<p>Sub-clause 4.25.1</p> <p>Ambient temperature: 70 °C ± 2 °C</p> <p>Duration: 1000 h</p> <p>The voltage shall be applied in cycles of 1.5 h on and 0.5 h.</p> <p>The applied voltage shall be the rated voltage or the limiting element voltage whichever is the smaller.</p> <p>Examination at 48 h, 500 h and 1000 h:</p> <p>Visual examination</p> <p>Resistance</p> <p>Examination at 1000 h:</p> <p>Insulation resistance</p>	<p>No visible damage</p> <p>$\Delta R \leq \pm (10\%+0.5\Omega)$</p> <p>$R \geq 1 G\Omega$</p>

Table-4(4)

No	Test items	Condition of test (JIS C 5201-1)	Performance requirements	
9	Variation of resistance with temperature	Sub-clause 4.8 -55 °C / +20 °C +20 °C / +125°C	At -55°C	
			Resistance range(Ω)	Temperature coefficient(%)
			R≤1kΩ	+6.5-0(%)
			R≤10kΩ	+10-0(%)
			R≤100kΩ	+13-0(%)
			R≤1MΩ	+15-0(%)
			R>1MΩ	+20-0(%)
			At +125°C	
			Resistance range(Ω)	Temperature coefficient(%)
			R≤1kΩ	+1-5(%)
			R≤10kΩ	0-6(%)
			R≤100kΩ	0-7.5(%)
			R≤1MΩ	0-10(%)
			R>1MΩ	0-15(%)
10	Damp heat, steady state	Sub-clause 4.24 Ambient temperature: 40 °C ± 2 °C Relative humidity : 93 \pm ₃ % a) 1st group: without voltage applied. b) 2nd group: The d.c.voltage shall be applied continuously. The voltage shall be accordance with Sub-clause 4.24.2.1 b). c) 3rd group: The d.c.voltage shall be applied continuously. The voltage: 20 V ± 2 V Visual examination Resistance Insulation resistance	No visible damage Legible marking $\Delta R \leq \pm (10\%+0.5\Omega)$ R ≥ 100 MΩ	
11	Dimensions (detail)	Sub-clause 4.4.3	As in Table-3	
	Endurance at upper category temperature	Sub-clause 4.25.3 Ambient temperature: 125 °C ± 2 °C Duration: 1000 h Examination at 48 h, 500 h and 1000 h: Visual examination Resistance Examination at 1000h: Insulation resistance	No visible damage $\Delta R \leq \pm (10\%+0.5\Omega)$ R ≥ 1 GΩ	

8. Horizontal forming

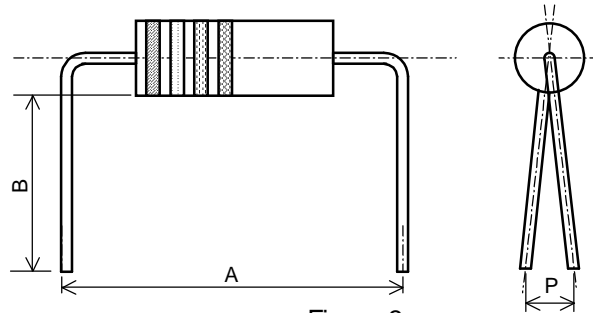

Figure-3

Table-5

Unit:mm

Style	Packaging form symbol	A	B	P
RC1/2	H	15.0 ± 0.5	5.0 ± 0.5	1.8max.
RC1/4	H60	10.0 ± 0.5	5.0 ± 0.5	1.5max.
	H62	12.5 ± 0.5		

9. Taping design and dimensions

9.1 Applicable document JIS C 0806-1:1999

9.2 Taping design and dimensions shall be in accordance with Figure-4 and Table-6.

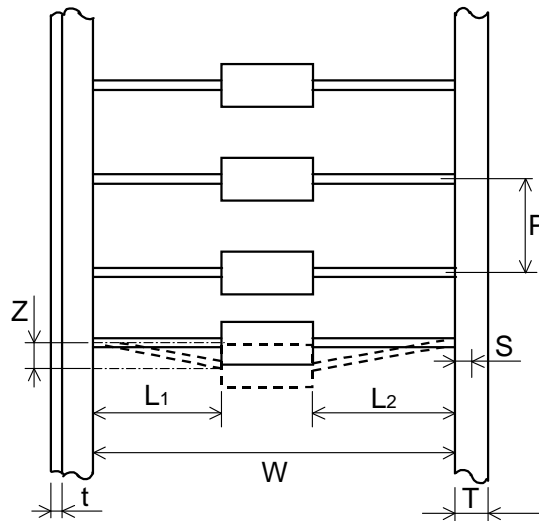

Figure-4

Table-6

Unit:mm

Style	W	P	L1-L2	Z	S	T	t
RC1/2	52.4 ^{+1.6} / _{-1.4}	5.08 ± 0.38	1.0max.	1.0max.	3.2min.	6.0 ± 0.5	0.5max.
RC1/4							

9.3 Notes

- 9.3.1 The direction of color codes should be on unified.
- 9.3.2 No component shall be missed.
- 9.3.3 The wire leads shall be free from kinks and bends.
- 9.3.4 Pitches tolerance is 2mm(100±2mm) for 20 pitches.
- 9.3.5 The edge waving of tape shall be not more than ±1.0mm through a length of 300mm.
- 9.3.6 The reinforcement of the tape cutting should be reinforced by a new tape (30mm min.) in 3mm limits and insuring 1 pitch dimension as shown in Figure-5.

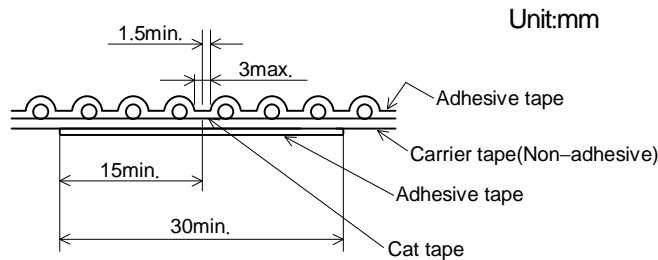

Figure-5

9.2 Taped and box

The box shall be of the design and physical dimensions in accordance with Figure-6 and Table-7.
The box of materials shall be carton.

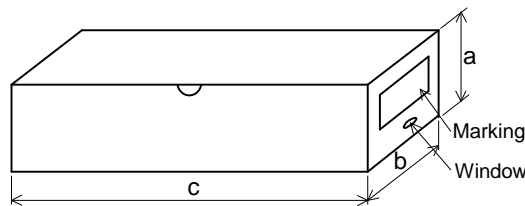

Figure-6

Table-7

Unit:mm

Style	Packaging form symbol	a	b	c
RC1/2	TB	65 ± 5	75 ± 5	455 ± 5
RC1/4		60 ± 5	75 ± 5	275 ± 5

9.3 Taping reel

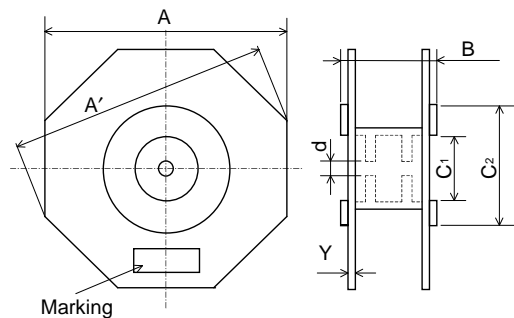

Figure-7

Table-8

Unit:mm

Style	Packaging form symbol	A	A'	B	C ₁	C ₂	d	Y
RC1/2	TD	260 ± 5	* 280	75 ± 5	60.4 ± 1.0	78 ± 1	14.5 ± 0.5	* 3
RC1/4								

*Reference

X-ON Electronics

Largest Supplier of Electrical and Electronic Components

Click to view similar products for [Carbon Composition Resistors](#) category:

Click to view products by [Kamaya](#) manufacturer:

Other Similar products are found below :

[OE5655](#) [OG5625](#) [OB1025](#) [OE1855](#) [OG2005](#) [OC2255](#) [OH6205](#) [QWCC339](#) [CF1/4W-18±5% T52](#) [RC0S2CA270RKE](#) [RC1/4272KB](#)
[OF110JE-TR](#) [CF18JT910R](#) [RCC050 10R JB](#) [RCC025 2R7 J B](#) [CBT50J6K8](#) [CBT50K680R](#) [CFR01SJ0101A10](#) [CFR01SJ0102A10](#)
[CFR01SJ0105A10](#) [CFR01SJ018JA10](#) [CFR01SJ0202A10](#) [CFR01SJ0274A10](#) [CFR01SJ0304A10](#) [CFR01SJ0331A10](#) [CFR01SJ0361A10](#)
[CFR01SJ0390A10](#) [CFR01SJ0393A10](#) [CFR01SJ0470A10](#) [CFR01SJ051JA10](#) [CFR01SJ0560A10](#) [CFR01SJ0683A10](#) [CFR01SJ0820A10](#)
[CFR02SJ0100A10](#) [CFR02SJ0101A10](#) [CFR02SJ0103A10](#) [CFR02SJ0121AA0](#) [CFR02SJ0151AA0](#) [CFR02SJ0154AA0](#) [CFR02SJ0205A10](#)
[CFR02SJ0220A10](#) [CFR02SJ0224A10](#) [CFR02SJ022JA10](#) [CFR02SJ027JA10](#) [CFR02SJ0303A10](#) [CFR02SJ0333A10](#) [CFR02SJ0393AA0](#)
[CFR02SJ0431A10](#) [CFR02SJ0681A10](#) [CFR03SJ0100AA0](#)