

Data sheet

Title: FIXED THICK FILM CHIP RESISTORS; RECTANGULAR TYPE & PRECISION

Style: RGC1/32,1/20,1/16S,1/16,1/10,1/8

AEC-Q200 qualified (Without RGC1/32)

RoHS COMPLIANCE ITEM

Halogen and Antimony Free

Note: • Stock conditions

Temperature: +5°C ~ +35°C

Relative humidity: 25% ~ 75%

The period of guarantee: Within 2 year from shipment by the company.
Solderability shall be satisfied.

- Product specification contained in this data sheet are subject to change at any time without notice.
- If you have any questions or a Purchasing Specification for any quality Agreement is necessary, please contact our sales staff.



釜屋電機株式会社
KAMAYA ELECTRIC CO., LTD.

Hokkaido Research Center
Approval by: T. Sannomiya
Drawing by: M. Shibuya

1. Scope

1.1 This data sheet covers the detail requirements for fixed thick film chip resistors; rectangular type & precision, style of RGC1/32,1/20,1/16S,1/16,1/10,1/8.

1.2 Applicable documents

JIS C 5201-1: 2011, JIS C 5201-8: 2014, JIS C 5201-8-1: 2014
 IEC60115-1: 2008, IEC60115-8: 2009, IEC60115-8-1: 2014
 EIAJ RC-2134C-2010

2. Classification

Type designation shall be the following form.

(Example)

RGC	1/8	C	123	D	TP
1	2	3	4	5	6
Style					

- 1 Fixed thick film chip resistors; rectangular type & precision Style
- 2 Rated dissipation and / or dimension
- 3 Temperature coefficient of resistance

K	$\pm 100 \times 10^{-6} / ^\circ\text{C}$
C	$\pm 50 \times 10^{-6} / ^\circ\text{C}$

4 Rated resistance

123	E24 Series, 3 digit, Ex. 123--> 12k Ω ,
1000	E96 Series, 4 digit, Ex. 1000-->100 Ω 1022--> 10.2k Ω

5 Tolerance on rated resistance

B	$\pm 0.1\%$
D	$\pm 0.5\%$
F	$\pm 1\%$

6 Packaging form

B	Bulk (loose package)
PA	Press pocket taping
TH	Paper taping
TP	

3. Rating

3.1 The ratings shall be in accordance with Table-1.

Table-1

Style	Rated dissipation (W)	Temperature coefficient of resistance ($10^{-6} / ^\circ\text{C}$)		Rated resistance range(Ω)	Preferred number series for resistors	Tolerance on rated resistance
RGC1/32	0.03	C	± 50	100~100k	E24,96	D($\pm 0.5\%$)
RGC1/20	0.05	C	± 50	1k~1M	E24,96	B($\pm 0.1\%$), D($\pm 0.5\%$)
		K	± 100	51~97.6		
RGC1/16S	0.063	C	± 50	100~1M	E24,96	B($\pm 0.1\%$), D($\pm 0.5\%$) F($\pm 1\%$)
		K	± 100	1.02M~3.3M 10~97.6		
RGC1/16	0.1	C	± 50	100~1M	E24,96	B($\pm 0.1\%$), D($\pm 0.5\%$) F($\pm 1\%$) D($\pm 0.5\%$)F($\pm 1\%$)
		K	± 100	1.02M~3.3M 10~97.6		
				3.3~9.76		
RGC1/10	0.125	C	± 50	10~3.3M	E24,96	B($\pm 0.1\%$), D($\pm 0.5\%$) F($\pm 1\%$) D($\pm 0.5\%$)F($\pm 1\%$)
				3.3~9.76		
RGC1/8	0.25	C	± 50	10~4.7M	E24,96	B($\pm 0.1\%$), D($\pm 0.5\%$) F($\pm 1\%$) F($\pm 1\%$)
				3.3~9.76		

Style	Limiting element voltage (V)	Isolation voltage (V)	Category temperature range($^\circ\text{C}$)
RGC1/32	15	50	-55~+125
RGC1/20	25		
RGC1/16S	50	100	-55~+155
RGC1/16			
RGC1/10	150		
RGC1/8	200		

3.2 Climatic category

3.2.1 RGC1/32

55/125/56	Lower category temperature	- 55 $^\circ\text{C}$
	Upper category temperature	+125 $^\circ\text{C}$
	Duration of the damp heat, steady state test	56days

3.2.2 RGC1/20,1/16S,1/16,1/10,1/8

55/155/56	Lower category temperature	- 55 $^\circ\text{C}$
	Upper category temperature	+155 $^\circ\text{C}$
	Duration of the damp heat, steady state test	56days

3.3 Stability class

5%

Limits for change of resistance:

- for long - term tests	$\pm(5\%+0.1\Omega)$
- for short - term tests	$\pm(1\%+0.05\Omega)$

3.4 Derating

The derated values of dissipation at temperature in excess of 70 °C shall be as indicated by the following curve.

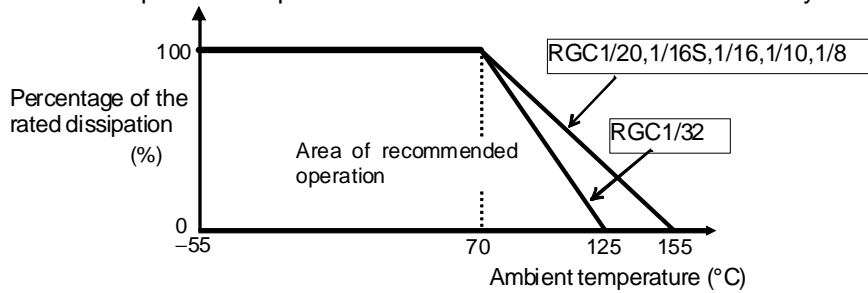

Figure-1 Derating curve

3.5 Rated voltage

d.c.or a.c.r.m.s.voltage calculated from the square root of the product of the rated resistance and the rated dissipation.

$$E = \sqrt{P \cdot R}$$

E: Rated voltage (V)

P: Rated dissipation (W)

R: Rated resistance (Ω)

Limiting element voltage can only be applied to resistors when the resistance value is equal to or higher than the critical resistance value.

At high value of resistance, the rated voltage may not be applicable.

4. Packaging form

The standard packaging form shall be in accordance with Table-2.

Table-2

Symbol	Packaging form		Standard packaging quantity / units	Application
B	Bulk (loose package)		1,000 pcs.	RGC1/32,1/20,1/16S,1/16,1/10,1/8
PA	Press pocket taping (paper taping)	8mm width, 2mm pitches	20,000 pcs.	RGC1/32
			15,000 pcs.	RGC1/20
TH	Paper taping	8mm width, 2mm pitches	10,000 pcs.	RGC1/16S
TP	Paper taping	8mm width, 4mm pitches	5,000 pcs.	RGC1/16, 1/10, 1/8

5. Dimensions

5.1 The resistor shall be of the design and physical dimensions in accordance with Figure-2 and Table-3.

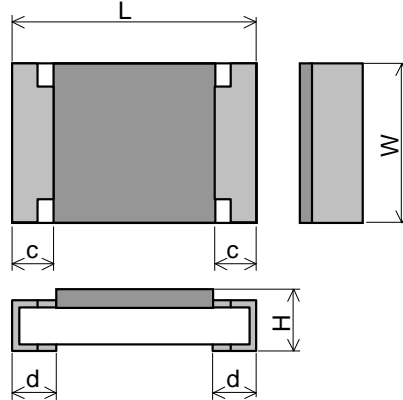

Figure-2

Table-3

Unit: mm

Style	L	W	H	c	d
RGC1/32	0.4±0.02	0.2±0.02	0.13±0.02	0.08±0.03	0.1±0.03
RGC1/20	0.6±0.03	0.3±0.03	0.23±0.03	0.1±0.05	0.15±0.05
RGC1/16S	1.0±0.05	0.5±0.05	0.35±0.05	0.2±0.1	0.25 ^{+0.05} _{-0.10}
RGC1/16	1.6±0.1	0.8 ^{+0.15} _{-0.05}	0.45±0.10	0.25±0.10	0.3±0.1
RGC1/10	2.0±0.1	1.25±0.10	0.6±0.1	0.4±0.2	0.4±0.2
RGC1/8	3.1±0.1	1.6±0.15	0.6±0.1	0.5±0.25	0.5±0.25

5.2 Net weight (Reference)

Style	Net weight(mg)
RGC1/32	0.035
RGC1/20	0.16
RGC1/16S	0.6
RGC1/16	2
RGC1/10	5
RGC1/8	9

6. Marking

The Rated resistance shall be marked in 3 digits (E24) or 4 digits (E96) and marked on over coat side.

- E24 series: 3 digits, E96 series: 4 digits

In case of the resistance value that E96 overlaps with E24, It is marked by either.

The Rated resistance of RGC1/16 should not be marked in 4 digits.

The Rated resistance of RGC1/32,1/20,1/16S should not be marked.

Marking example	Contents	Application
123	12×10 ³ [Ω] → 12 [kΩ]	RGC1/16,1/10,1/8
3R3	3.3 [Ω]	Less than 10Ω of RGC1/16,1/10,1/8
5623	562×10 ³ [Ω] → 562[kΩ]	RGC1/10,1/8
12R7	12.7 [Ω]	RGC1/10,1/8

7. Performance

7.1 The standard condition for tests shall be in accordance with Sub-clause 4.2, JIS C 5201-1: 2011.

7.2 The performance shall be satisfied in Table-4.

Table-4(1)

No.	Test items	Condition of test (JIS C 5201-1)	Performance requirements
1	Visual examination	Sub-clause 4.4.1 Checked by visual examination.	As in 4.4.1 The marking shall be legible, as checked by visual examination.
2	Dimension Resistance	Sub-clause 4.4.2 Sub-clause 4.5	As specified in Table-3 of this specification. As in 4.5.2 The resistance value shall correspond with the rated resistance taking into account the specified tolerance.
3	Voltage proof	Sub-clause 4.7 Method: 4.6.1.4(See Figure-5) Test voltage: Alternating voltage with a peak value of 1.42 times the insulation voltage. Duration: 60 s \pm 5 s Insulation resistance Test voltage: Insulation voltage Duration: 1 min.	No breakdown or flash over $R \geq 1 \text{ G } \Omega$
4	Solderability	Sub-clause 4.17 Without ageing Flux: The resistors shall be immersed in a non-activated soldering flux for 2s. Bath temperature: 235 $^{\circ}\text{C} \pm 5 \text{ }^{\circ}\text{C}$ Immersion time: 2 s \pm 0.5 s	As in 4.17.4.5 The terminations shall be covered with a smooth and bright solder coating.
5	Mounting Overload (in the mounted state) Solvent resistance of the marking	Sub-clause 4.31 Substrate material: Epoxide woven glass Test substrate: Figure-3 Sub-clause 4.13 The applied voltage shall be 2.5 times the rated voltage or twice the limiting element voltage, whichever is the less severe. Duration: 2 s Visual examination Resistance Sub-clause 4.30 Solvent: 2-propanol Solvent temperature: 23 $^{\circ}\text{C} \pm 5 \text{ }^{\circ}\text{C}$ Method 1 Rubbing material: cotton wool Without recovery	No visible damage $\Delta R \leq \pm (1\%+0.05\Omega)$ Legible marking

Table-4(2)

No	Test items	Condition of test (JIS C 5201-1)	Performance requirements
6	Mounting Bound strength of the end face plating Final measurements	Sub-clause 4.31 Substrate material: Epoxide woven glass Test substrate: Figure-4 Sub-clause 4.33 Bent value: 3 mm Resistance Sub-clause 4.33.6 Visual examination	$\Delta R \leq \pm (1\%+0.05\Omega)$ No visible damage
7	Resistance to soldering heat Component resistance solvent	Sub-clause 4.18 Solder temperature: 260 °C ± 5 °C Immersion time: 10 s ± 0.5 s Visual examination Resistance Sub-clause 4.29 Solvent: 2-propanol Solvent temperature: 23 °C ± 5 °C Method 2 Recovery: 48 h Visual examination Resistance	As in 4.18.3.4 No sign of damage such as cracks. $\Delta R \leq \pm (1\%+0.05\Omega)$ No visible damage $\Delta R \leq \pm (1\%+0.05\Omega)$
8	Mounting Adhesion Rapid change temperature	Sub-clause 4.31 Substrate material: Epoxide woven glass Test substrate: Figure-3 Sub-clause 4.32 Force: 5 N(RGC1/32: 2N, RGC1/20: 3N) Duration: 10 s ± 1 s Visual examination Sub-clause 4.19 RGC1/32 Lower category temperature: -55 °C Upper category temperature: +125 °C RGC1/20,1/16S,1/16,1/10,1/8 Lower category temperature: -55 °C Upper category temperature: +155 °C Duration of exposure at each temperature: 30 min. Number of cycles: 5 cycles. Visual examination Resistance	No visible damage No visible damage $\Delta R \leq \pm (1\%+0.05\Omega)$

Table-4(3)

No	Test items	Condition of test (JIS C 5201-1)	Performance requirements
9	Climatic sequence -Dry heat -Damp heat, cycle (12+12hour cycle) First cycle -Cold -Damp heat, cycle (12+12hour cycle) Remaining cycle -D.C. load	Sub-clause 4.23 Sub-clause 4.23.2 RGC1/32 Test temperature: +125 °C RGC1/20,1/16S,1/16,1/10,1/8: Test temperature: +155 °C Duration: 16 h Sub-clause 4.23.3 Test method: 2 Test temperature: 55 °C [Severity(2)] Sub-clause 4.23.4 Test temperature -55 °C Duration: 2h Sub-clause 4.23.6 Test method: 2 Test temperature: 55 °C [Severity (2)] Number of cycles: 5 cycles Sub-clause 4.23.7 The applied voltage shall be the rated voltage or the limiting element voltage whichever is the smaller. Duration: 1 min. Visual examination Resistance	No visible damage $\Delta R \leq \pm (5\%+0.1\Omega)$
10	Mounting Endurance at 70 °C	Sub-clause 4.31 Substrate material: Epoxide woven glass Test substrate: Figure-3 Sub-clause 4.25.1 Ambient temperature: 70 °C ± 2 °C Duration: 1000 h The voltage shall be applied in cycles of 1.5 h on and 0.5 h. The applied voltage shall be the rated voltage or the limiting element voltage whichever is the smaller. Examination at 48 h, 500 h and 1000 h: Visual examination Resistance	No visible damage $\Delta R \leq \pm (5\%+0.1\Omega)$

Table-4(4)

No	Test items	Condition of test (JIS C 5201-1)	Performance requirements
11	Mounting Variation of resistance with temperature	Sub-clause 4.31 Substrate material: Epoxide woven glass Test substrate: Figure-3 Sub-clause 4.8 RGC1/32: +20 °C / +125°C RGC1/20,1/16S,1/16,1/10,1/8: +20 °C / +155°C	As in Table-1
12	Mounting Damp heat, steady state	Sub-clause 4.31 Substrate material: Epoxide woven glass Test substrate: Figure-3 Sub-clause 4.24 Ambient temperature: 40 °C ± 2 °C Relative humidity : 93 $\frac{2}{3}$ % a) 1st group: without voltage applied. b) 2nd group: The d.c.voltage shall be applied continuously. The voltage shall be accordance with Sub-clause 4.24.2.1 b). without polarizing voltage [4.24.2.1, c)] Visual examination Resistance	No visible damage Legible marking $\Delta R \leq \pm (5\%+0.1\Omega)$
13	Dimensions (detail) Mounting Endurance at upper category temperature	Sub-clause 4.4.3 Sub-clause 4.31 Substrate material: Epoxide woven glass Test substrate: Figure-3 Sub-clause 4.25.3 RGC1/32: Ambient temperature:125 °C ± 2 °C RGC1/20,1/16S,1/16,1/10,1/8: Ambient temperature:155 °C ± 2 °C Duration: 1000 h Examination at 48 h, 500 h and 1000 h: Visual examination Resistance	As in Table-3 No visible damage $\Delta R \leq \pm (5\%+0.1\Omega)$

8. Test substrate

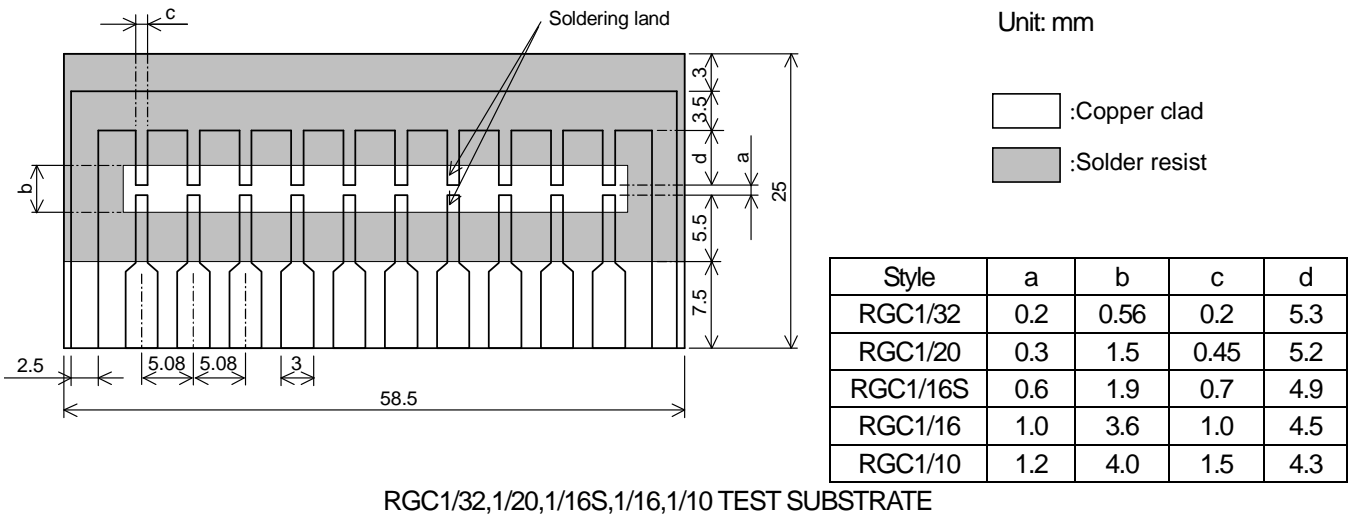
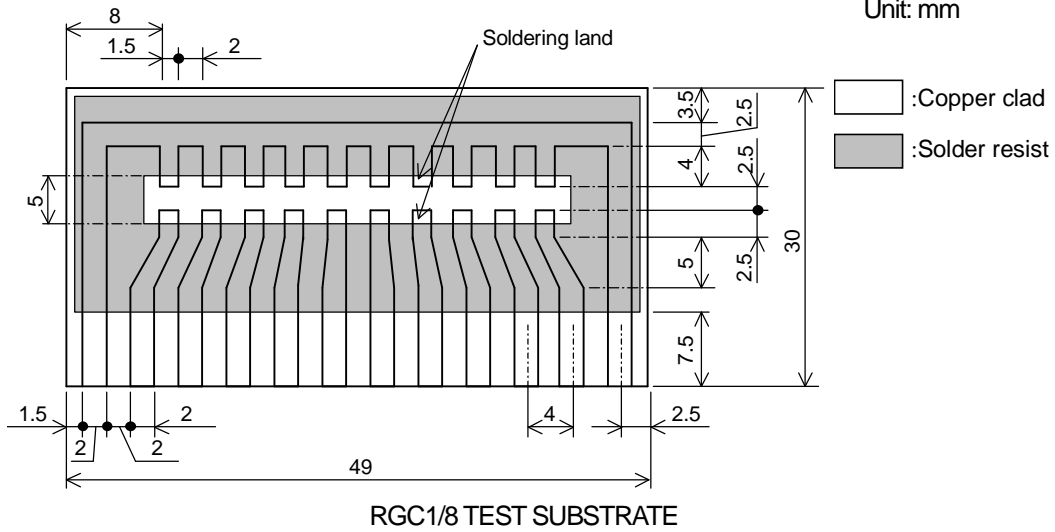
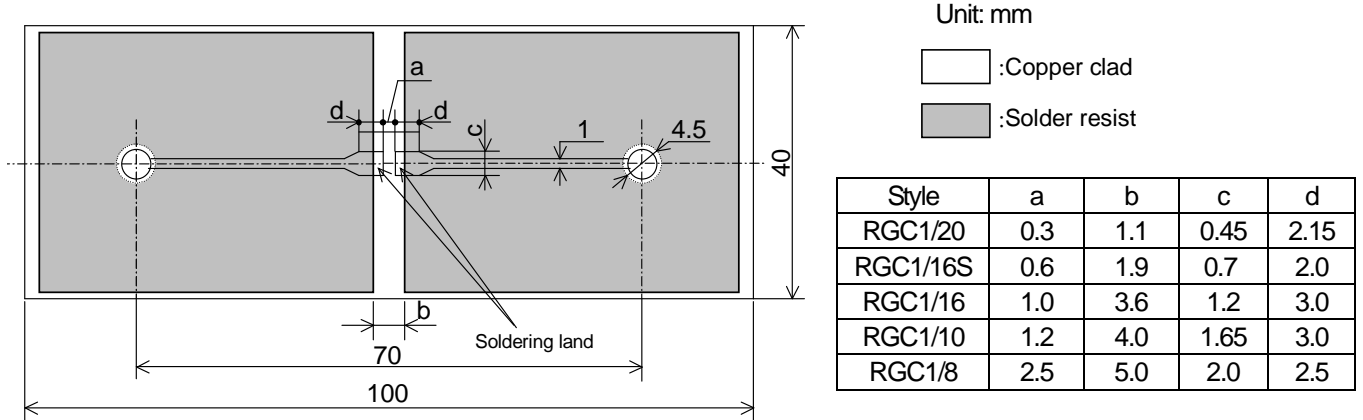
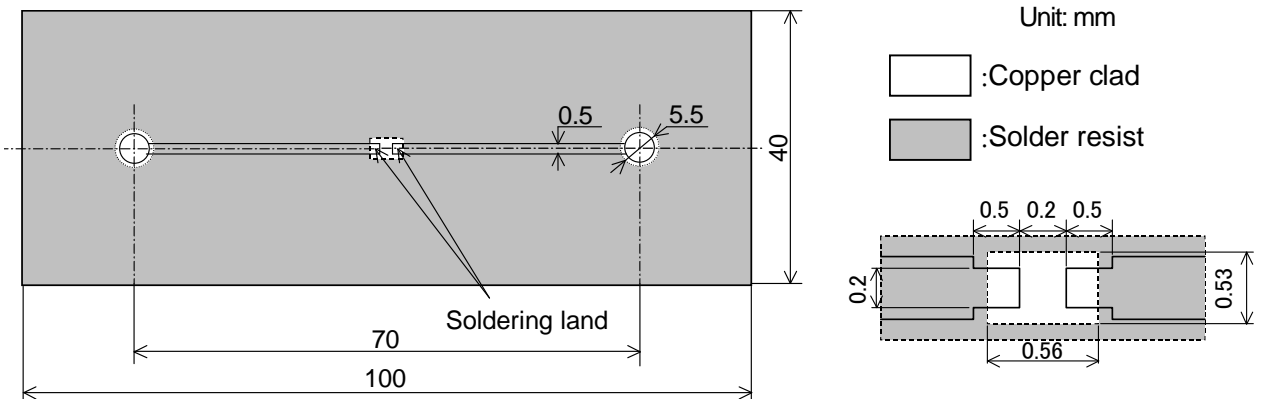

Figure-3

- Remark 1). Material: Epoxide woven glass
Thickness: 1.6mm Thickness of copper clad: 0.035mm
- 2). In the case of connection by connector, the connecting terminals are gold plated.
However, the plating is not necessary when the connection is made by soldering.



RGC BOUND STRENGTH OF THE END FACE PLATING TEST SUBSTRATE



RGC1/32 BOUND STRENGTH OF THE END FACE PLATING TEST SUBSTRATE

Figure-4

Remark 1). Material: Epoxide woven glass
Thickness: 1.6mm Thickness of copper clad: 0.035mm

•RGC1/16S,1/16,1/10,1/8

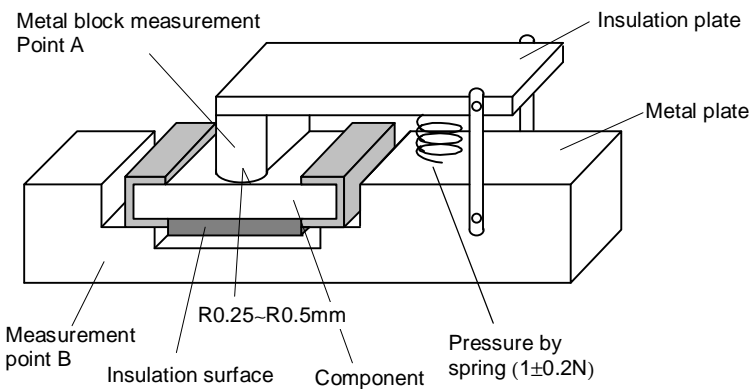

•RGC1/32,1/20

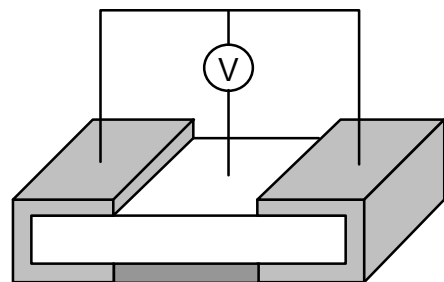

Figure-5

9. Taping

9.1 Applicable documents JIS C 0806-3: 2014, EIAJ ET-7200C: 2010

9.2 Taping dimensions

9.2.1 Press pocket taping (Paper taping, 8mm width, 2mm pitches)

Taping dimensions shall be in accordance with Figure-6 and Table-5.

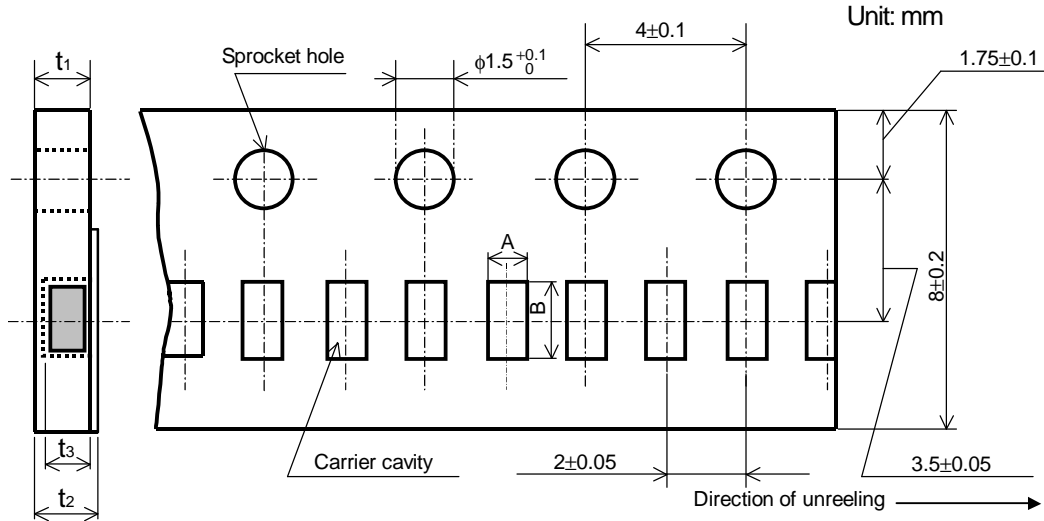

Figure-6

Table-5

Unit: mm

Style	A	B	t_1	t_2	t_3
RGC1/32	0.24 ± 0.03	0.45 ± 0.03	0.31 ± 0.03	0.36 ± 0.03	0.15 ± 0.02
RGC1/20	0.37 ± 0.05	0.67 ± 0.05	0.42 ± 0.03	0.45 ± 0.05	0.27 ± 0.02

9.2.2 Paper taping (8mm width, 2mm pitches)

Taping dimensions shall be in accordance with Figure-7 and Table-6.

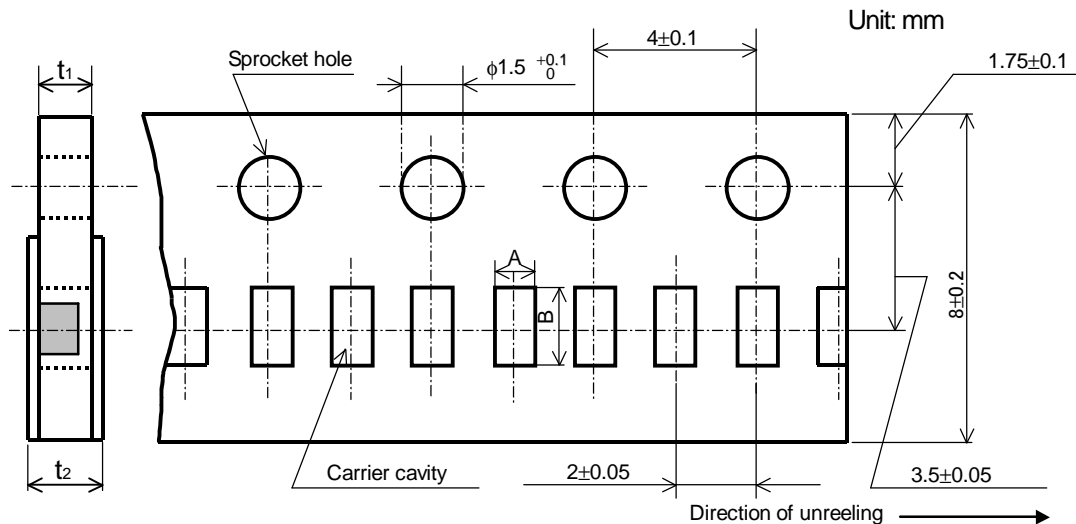

Figure-7

Table-6

Unit: mm

Style	A	B	t_1	t_2
RGC1/16S	$0.65^{+0.05}_{-0.10}$	$1.15^{+0.05}_{-0.10}$	0.4 ± 0.05	0.5max.

9.2.3 Paper taping (8mm width, 4mm pitches)

Taping dimensions shall be in accordance with Figure-8 and Table-7.

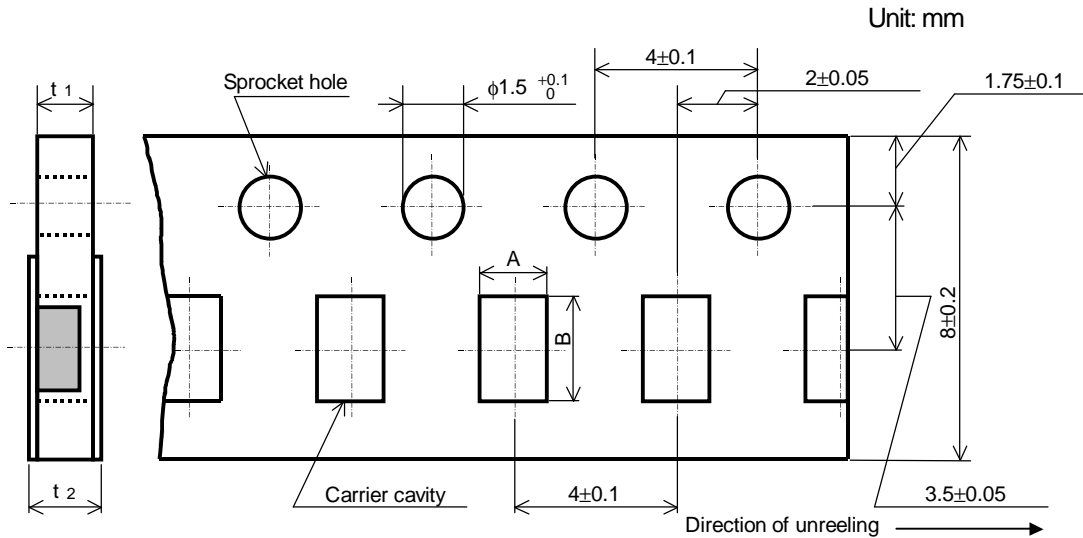

Figure-8

Table-7

Unit: mm

Style	A	B	t_1	t_2
RGC1/16	1.15 ± 0.15	1.9 ± 0.2	0.6 ± 0.1	0.8max.
RGC1/10	1.65 ± 0.15	2.5 ± 0.2	0.8 ± 0.1	1.0max.
RGC1/8	2.00 ± 0.15	3.6 ± 0.2		

- 1). The cover tapes shall not cover the sprocket holes.
- 2). Tapes in adjacent layers shall not stick together in the packing.
- 3). Components shall not stick to the carrier tape or to the cover tape.
- 4). Pitch tolerance over any 10 pitches ± 0.2 mm.
- 5). The peel strength of the top cover tape shall be within 0.1N to 0.5N on the test method as shown in the following
RGC1/32,1/20: Figure-9, RGC1/16S, 1/16, 1/10, 1/8: Figure-10.
- 6). When the tape is bent with the minimum radius for 25 mm, the tape shall not be damaged and the components shall maintain their position and orientation in the tape.
- 7). In no case shall there be two or more consecutive components missing.
The maximum number of missing components shall be one or 0.1%, whichever is greater.
- 8). The resistors shall be faced to upward at the over coating side in the carrier cavity.

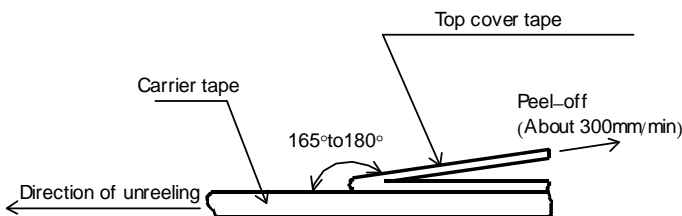

Figure-9

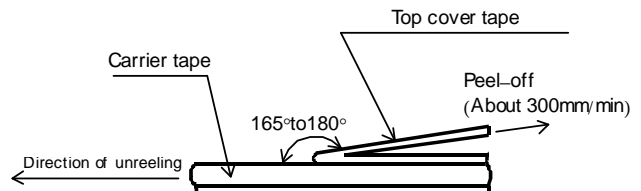

Figure-10

9.3 Reel dimension

Reel dimensions shall be in accordance with the following Figure-11 and Table-8.

Plastic reel (Based on EIAJ ET-7200C)

Unit: mm

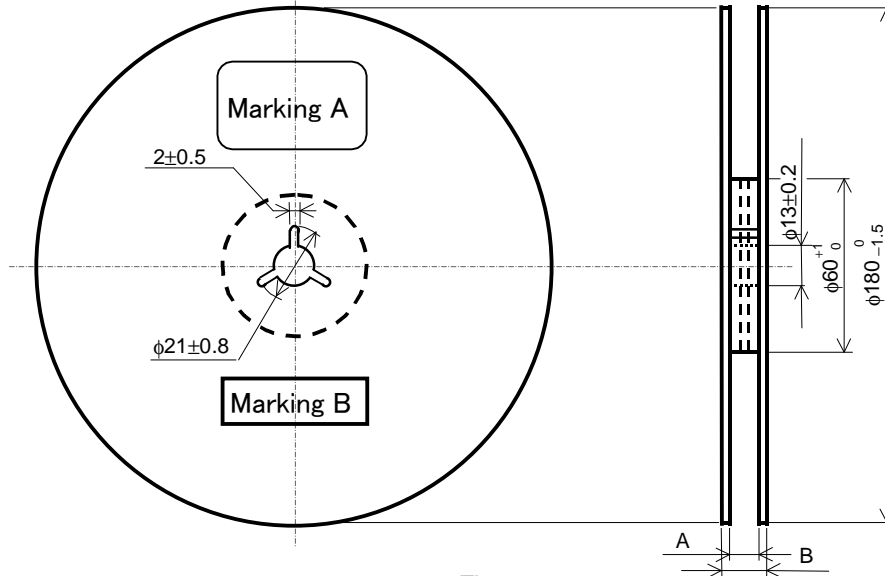

Figure-11

Table-8

Unit: mm

Style	A	B	Note
RGC1/32,1/20,1/16S,1/16,1/10,1/8	9 ^{+1.0} / ₀	11.4±1.0	Injection molding
		13±1.0	Vacuum forming

Note: Marking label shall be marked on a place of Marking A or two place of marking A and B.

9.4 Leader and trailer tape.

(Example)

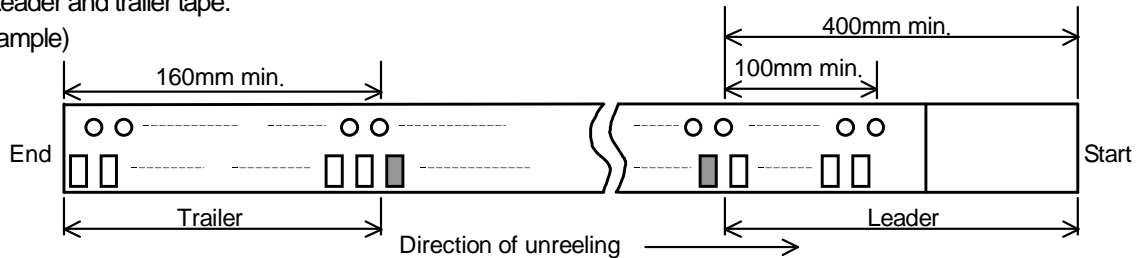

Figure-12

10. Marking on package

The label of a minimum package shall be legibly marked with follows.

10.1 Marking A

(1) Classification

(Style, Temperature coefficient of resistance, Rated resistance, Tolerance on rated resistance, Packaging form)

(2) Quantity (3) Lot number (4) Manufacturer's name or trade mark (5) Others

10.2 Marking B (KAMAYA control label)

X-ON Electronics

Largest Supplier of Electrical and Electronic Components

Click to view similar products for [Thick Film Resistors - SMD category](#):

Click to view products by [Kamaya manufacturer](#):

Other Similar products are found below :

[CR-05FL7--150R](#) [CR-05FL7--698K](#) [CR-12FP4--324R](#) [CR-12JP4--680R](#) [M55342K06B10D0RS6](#) [M55342K06B14E0RS6](#)
[M55342K06B1E78RS3](#) [M55342K06B24E9RS6](#) [M55342K06B6E19RWL](#) [M55342K06B6E81RS3](#) [M55342M05B200DRWB](#)
[M55342M06B4K70MS3](#) [MC0603-511-JTW](#) [742C083750JTR](#) [MCR01MZPF1202](#) [MCR01MZPF1601](#) [MCR01MZPF1800](#)
[MCR01MZPF6201](#) [MCR01MZPF9102](#) [MCR01MZPJ113](#) [MCR01MZPJ121](#) [MCR01MZPJ125](#) [MCR01MZPJ751](#) [MCR03EZHJ103](#)
[MCR03EZPF2004](#) [MCR03EZPJ270](#) [MCR03EZPJ821](#) [MCR10EZPF1102](#) [MCR10EZPF2700](#) [MCR18EZPJ330](#) [RC1005F1152CS](#)
[RC1005F1182CS](#) [RC1005F1372CS](#) [RC1005F183CS](#) [RC1005F1911CS](#) [RC1005F1912CS](#) [RC1005F203CS](#) [RC1005F2052CS](#)
[RC1005F241CS](#) [RC1005F2431CS](#) [RC1005F3011CS](#) [RC1005F303CS](#) [RC1005F4321CS](#) [RC1005F4642CS](#) [RC1005F471CS](#)
[RC1005F4751CS](#) [RC1005F5621CS](#) [RC1005F6041CS](#) [RC1005J106CS](#) [RC1005J121CS](#)