

# Data sheet

Title: FIXED THICK FILM CHIP RESISTORS;  
RECTANGULAR TYPE

Style: RMC10,16,20,32,35

Automotive Grade  
AEC-Q200 qualified

RoHS COMPLIANCE ITEM  
Halogen and Antimony Free

- Note:
- Stock conditions  
Temperature: +5°C ~ +35°C  
Relative humidity: 25% ~ 75%  
The period of guarantee: Within 2 year from shipment by the company.  
Solderability shall be satisfied.
  - Product specification contained in this data sheet are subject to change at any time without notice
  - If you have any questions or a Purchasing Specification for any quality Agreement is necessary, please contact our sales staff.



**釜屋電機株式会社**  
**KAMAYA ELECTRIC CO., LTD.**

Hokkaido Research Center  
Approval by: T. Sannomiya  
Drawing by: M. Shibuya

## 1. Scope

1.1 This specification covers the detail requirements for fixed thick film chip resistors; rectangular type, style of RMC10, 16, 20,32, 35.

### 1.2 Applicable documents

JIS C 5201-1: 2011, IEC60115-1: 2008, AEC-Q200 Rev.D

### 1.3 For Automotive Grade

- AEC-Q200 qualified (Grade 0)
- Managed and manufactured under the exclusive manufacturing process for automotive.

## 2. Classification

Type designation shall be the following form.

(Example)	1)	RMC	32	-	123	J	TP
		1	2	3	4	5	6
		Style					
	2)	RMC	32		JP		TP
		1	2		4		6
		Style					

1 Fixed thick film chip resistors; rectangular type

2 Rated dissipation and / or dimension

3 Temperature coefficient of resistance



K	$\pm 100 \times 10^{-6} / ^\circ\text{C}$
-(Dash)	Standard

4 Rated resistance

123	E24 Series, 3 digit, Ex. 123--> 12k $\Omega$ ,
1000	E96 Series, 4 digit, Ex. 1000-->100 $\Omega$ 1022--> 10.2k $\Omega$
JP	Chip jumper

5 Tolerance on rated resistance

B	$\pm 0.1\%$
D	$\pm 0.5\%$
F	$\pm 1\%$
G	$\pm 2\%$
J	$\pm 5\%$

6 Packaging form 1. Scope

B	Bulk (loose package)
TH	Paper taping
TP	
TE	Embossed taping

### 3. Rating

3.1 The ratings shall be in accordance with Table-1.

Table-1(1)

Style	Rated dissipation (W)	Temperature coefficient of resistance ( $10^{-6} / ^\circ\text{C}$ )		Rated resistance range ( $\Omega$ )	Preferred number series for resistors	Tolerance on rated resistance	
RMC10	0.1	K	$\pm 100$	10~1M	E24, 96	B( $\pm 0.1\%$ ) D( $\pm 0.5\%$ )	
			Standard	$\pm 200$		1.02M~3.3M	D( $\pm 0.5\%$ )
		K	$\pm 100$	10~1M		E24	F( $\pm 1\%$ )
			Standard	$\pm 200$			1.02M~10M
		+500~-200		1~9.76			
		$\pm 200$		10~10M			
		$\pm 200$		10~10M			
		+500~-200	1~9.1				
RMC16	0.1	K	$\pm 100$	10~3.3M	E24, 96	B( $\pm 0.1\%$ ) D( $\pm 0.5\%$ )	
			$\pm 100$	10~10M		F( $\pm 1\%$ )	
		Standard	+500~-200	1~9.76		E24	G( $\pm 2\%$ )
			$\pm 200$	10~10M			
			+500~-200	1.0~9.1			
			$\pm 200$	10~22M			
			+500~-200	1.0~9.1			
		RMC20	0.125	K	$\pm 100$	10~2.2M	E24,96
Standard	$\pm 200$				2.21M~3.3M	D( $\pm 0.5\%$ )	
K	$\pm 100$			10~2.2M	E24	F( $\pm 1\%$ )	
	Standard			$\pm 200$		2.21M~10M	
+500~-200				1.0~9.76			
$\pm 200$				10~10M			
+500~-200				1.0~9.1			
$\pm 200$	10~22M						
+500~-200	1.0~9.1						
RMC32	0.25	K	$\pm 100$	10~1M	E24,96	B( $\pm 0.1\%$ ) D( $\pm 0.5\%$ ) F( $\pm 1\%$ )	
			Standard	$\pm 200$		1.02M~10M	F( $\pm 1\%$ )
		+500~-200		1.0~9.76			
		$\pm 200$		10~10M		E24	G( $\pm 2\%$ )
		+500~-200		1.0~9.1			
		$\pm 200$	10~24M				
		+500~-200	1.0~9.1				
		RMC35	0.5	K	$\pm 100$	10~1M	E24,96
Standard	$\pm 200$				1.02M~10M	F( $\pm 1\%$ )	
	+500~-200			1.0~9.76			
	$\pm 200$			10~1M	E24	G( $\pm 2\%$ )	
	$\pm 200$			10~22M			
+500~-200	1.0~9.1			J( $\pm 5\%$ )			

Table-1(2)

Style	Limiting element voltage (V)	Isolation voltage (V)	Category temperature range (°C)
RMC10	50	100	-55~+155
RMC16			
RMC20	150	500	
RMC32			
RMC35	200		

Note. Rated current of chip jumper: RMC10: 1(A), RMC16, 20, 32, 35: 2(A)

Note. Resistance value of chip jumper: 50 mΩ max.

### 3.2 Climatic category

55/155/56

Lower category temperature	- 55 °C
Upper category temperature	+155 °C
Duration of the damp heat, steady state test	56days

### 3.3 Stability class

2%

Limits for change of resistance:

 -for long-term tests  $\pm(2\%+0.1\Omega)$  Chip jumper: 50 mΩ max.

 -for short-term tests  $\pm(0.5\%+0.05\Omega)$  Chip jumper: 50 mΩ max.

### 3.4 Derating

The derated values of dissipation (or current rating in case of chip jumper) at temperature in excess of 70 °C shall be as indicated by the following curve.

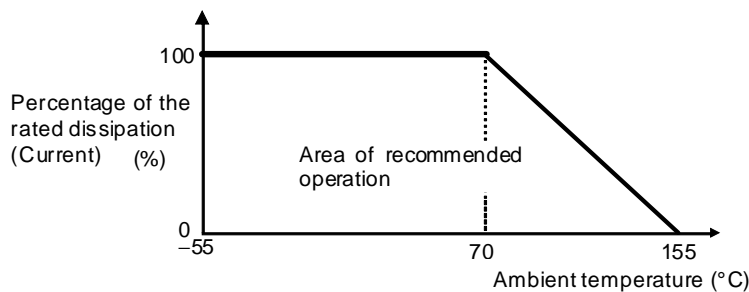

Figure-1 Derating curve

### 3.5 Rated voltage

d. c. or a. c. r. m. s. voltage calculated from the square root of the product of the rated resistance and the rated dissipation.

$$E = \sqrt{P \cdot R}$$

E : Rated voltage (V)

P : Rated dissipation (W)

R : Rated resistance (Ω)

Limiting element voltage can only be applied to resistors when the resistance value is equal to or higher than the critical resistance value.

At high value of resistance, the rated voltage may not be applicable.

#### 4. Packaging form

The standard packaging form shall be in accordance with Table-2.

Table-2

Symbol	Packaging form		Standard packaging quantity / units	Application
B	Bulk (loose package)		1,000 pcs.	RMC10,16,20,32,35
TH	Paper taping	8mm width, 2mm pitches	10,000 pcs.	RMC10
TP	Paper taping	8mm width, 4mm pitches	5,000 pcs.	RMC16, 20, 32
TE	Embossed taping	8mm width, 4mm pitches	4,000 pcs.	RMC35

#### 5. Dimensions

5.1 The resistor shall be of the design and physical dimensions in accordance with Figure-2 and Table-3.

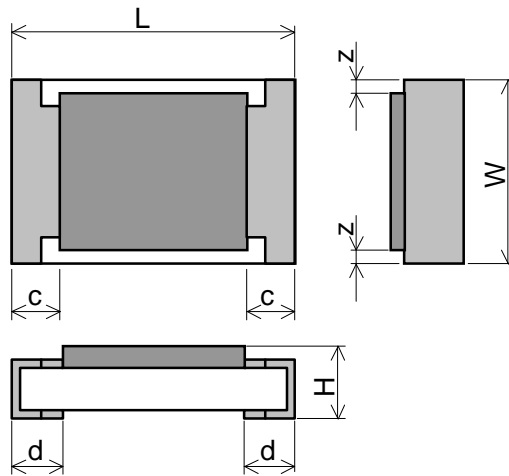

Figure-2

Table-3

Unit : mm

Style	L	W	H	c	d	z
RMC10	1.0±0.05	0.5±0.05	0.35±0.05	0.2±0.1	0.25 <sup>+0.05</sup> <sub>-0.10</sub>	-----
RMC16	1.6±0.1	0.8 <sup>+0.15</sup> <sub>-0.05</sub>	0.45±0.10	0.3±0.1	0.3±0.1	-----
RMC20	2.0±0.1	1.25±0.10	0.55±0.10	0.4±0.2	0.4±0.2	-----
RMC32	3.1±0.1	1.6±0.15	0.55±0.10	0.5±0.25	0.5±0.25	0.05~0.3
RMC35	3.1±0.15	2.5±0.15	0.55±0.15	0.5±0.25	0.5±0.25	0.05~0.3

#### 5.2 Net weight (Reference)

Style	Net weight(mg)
RMC10	0.6
RMC16	2
RMC20	5
RMC32	9
RMC35	16

## 6. Marking

The Rated resistance of RMC 10 should not be marked.

### 6.1 RMC20,32,35.

The nominal resistance shall be marked in 3 digits or 4 digits and marked on over coat side.

- E24 series: 3 digits, E96 series: 4 digits

In case of the resistance value that E96 overlaps with E24, It is marked by either.

Marking example	Contents	Application
123	$12 \times 10^3$ [ $\Omega$ ] $\rightarrow$ 12 [k $\Omega$ ]	RMC20,32,35
2R2	2.2 [ $\Omega$ ]	Less than 10 $\Omega$ of RMC32,35
2.2	2.2 [ $\Omega$ ]	Less than 10 $\Omega$ of RMC20
5623	$562 \times 10^3$ [ $\Omega$ ] $\rightarrow$ 562[k $\Omega$ ]	RMC20,32,35
12R7	12.7 [ $\Omega$ ]	RMC20,32,35

### 6.2 RMC16

The nominal resistance shall be marked in 3 digits and marked on over coat side.

No marking in the E96 series.

Marking example	Contents	Application
123	$12 \times 10^3$ [ $\Omega$ ] $\rightarrow$ 12 [k $\Omega$ ]	E24
2R2	2.2 [ $\Omega$ ]	E24
No marking	$102 \times 10^2$ [ $\Omega$ ] $\rightarrow$ 10.2 [k $\Omega$ ]	E96
No marking	$332 \times 10^{-1}$ [ $\Omega$ ] $\rightarrow$ 33.2 [ $\Omega$ ]	E96

### 6.3 Marking example of Jumper Chip

Marking example	Contents	Application
○ or 000	JP	RMC16
○		RMC20,32
000		RMC35

## 7. Performance

7.1 The standard condition for tests shall be in accordance with Sub-clause 4.2, JIS C 5201-1: 1998.

7.2 The performance shall be satisfied in Table-4.

Table-4(1)

No.	Test items	Condition of test	Performance requirements
1	High temperature exposure AEC Q200 - No.3	MIL-STD-202 Method 108 Ambient temperature: 155±2°C, Condition: Without load, Duration: 1000 <sup>+48</sup> <sub>0</sub> h Interval measurements: 250 h and 500 h	Resistor: ΔR/R: Within ±(2%+0.1Ω) Chip jumper: 50mΩ max. No visible damage
2	Temperature cycling AEC Q200 - No.4	JESD22 Method JA-104 Temperature: -55±3°C / 125±2°C, Dwell time: 30min maximum at each temp. Transition time: 1 min. max. Number of cycles: 1000 cycles. Interval measurements: 250 cy and 500 cy	Resistor: ΔR/R: Within ±(1%+0.05Ω) Chip jumper: 50mΩ max. No visible damage
3	Bias humidity AEC Q200 – No.7	MIL-STD-202 Method 103 Condition: 85°C & 85% R.H. Test power: 10% of rated power shall be applied for continuously. Duration: 1,000 <sup>+48</sup> <sub>0</sub> h Interval measurements: 250 h and 500 h	Resistor: ΔR/R: Within ±(2%+0.1Ω) Chip jumper: 50mΩ max. No visible damage
4	Operational life AEC Q200 – No.8	MIL-STD-202 Method 108 Ambient temperature: 125±2°C The applied voltage shall be the voltage to be calculated at 35% of rated dissipation or the limiting element voltage whichever is the smaller. Condition: The voltage shall be applied for continuously. Duration: 1000 <sup>+48</sup> <sub>0</sub> h Interval measurements: 250 h and 500 h	Resistor: ΔR/R: Within ±(2%+0.1Ω) Chip jumper: 50mΩ max. No visible damage
5	Dimensions AEC Q200 – No.10	JESD22 Method JB-100	As in Table-3
6	Resistance to Solvents AEC Q200 – No.12	MIL-STD-202 Method 215 Solvent: 2-propanol at 25°C Immersion time: 3 min Brush: 10 times brushing Immersion and brush cycle: 3cycle	Resistor: ΔR/R: Within ±(1%+0.05Ω) Chip jumper: 50mΩ max. No visible damage
7	Mechanical Shock AEC Q200 – No.13	MIL-STD-202 Method 213 Waveform: half sine, Peak value 100G, Normal duration 6ms Condition: XX'YY'ZZ', 10times each	Resistor: ΔR/R: Within ±(0.5%+0.05Ω) Chip jumper: 50mΩ max. No visible damage

Table-4(2)

No	Test items	Condition of test	Performance requirements
8	Vibration AEC Q200 – No.14	MIL-STD-202 Method 204 Peak acceleration and Sweep time: 5 g's for 20 min , Frequency 10Hz to 2000Hz, Condition: 12 cycles each of 3 orientations	Resistor: $\Delta R/R$ : Within $\pm(0.5\%+0.05\Omega)$ Chip jumper: 50m $\Omega$ max. No visible damage
9	Resistance to soldering heat AEC Q200 - No.15	MIL-STD-202 Method 210 Solder bath temp: 260 $\pm$ 5 $^{\circ}$ C Immersed time: 10 $\pm$ 1s	Resistor: $\Delta R/R$ : Within $\pm(0.5\%+0.05\Omega)$ Chip jumper: 50m $\Omega$ max. No visible damage
10	ESD test AEC Q200 – No.17	AEC-Q200-002 Human body model, 2 Kohm, 150 pF, Test voltage: RMC16,1/10.1/8,1/4 2000V RMC10 800V	Resistor: $\Delta R/R$ : Within $\pm(5\%+0.1\Omega)$ No visible damage
11	Solderability AEC Q200 – No.18	J-STD-002 a) Bake the sample for 155 $^{\circ}$ C dwell time 4h / solder dipping 235 $^{\circ}$ C/ 5s. Solder: Sn96.5-Ag3-Cu0.5 b) Category 3, Solder dipping 215 $^{\circ}$ C/ 5s. Solder: Sn63Pb37 c) Category 3, Solder dipping 260 $^{\circ}$ C/ 7s.	The surface of terminal immersed shall be min. of 95% covered with a new coating of solder.
12	Electrical Characterization AEC Q200 - No.19	1. D.C. Resistance 2. Temperature Coefficient of Resistance -55 $^{\circ}$ C / +20 $^{\circ}$ C +20 $^{\circ}$ C / +155 $^{\circ}$ C	1. The resistance value shall correspond with the rated resistance taking into account the specified tolerance. 2. As in Table-1
13	Bending strength AEC Q200 – No.21	AEC-Q200-005 Bending value 2mm Holding time: 60sec.	Resistor: $\Delta R/R$ : Within $\pm(0.5\%+0.05\Omega)$ Chip jumper: 50m $\Omega$ max. No visible damage
14	Adhesion AEC Q200 – No.22	AEC-Q200-006 Pressurizing force: RMC20,32,35 17.7N RMC10,16 10N Test time: 60 $\pm$ 1s.	Resistor: $\Delta R/R$ : Within $\pm(0.5\%+0.05\Omega)$ Chip jumper: 50m $\Omega$ max. No visible damage



## 9. Taping

9.1 Applicable documents JIS C 0806-3: 2014, EIAJ ET-7200C: 2010

### 9.2 Taping dimensions

#### 9.2.1 Paper taping (8mm width, 2mm pitches)

Taping dimensions shall be in accordance with Figure-3 and Table-5.

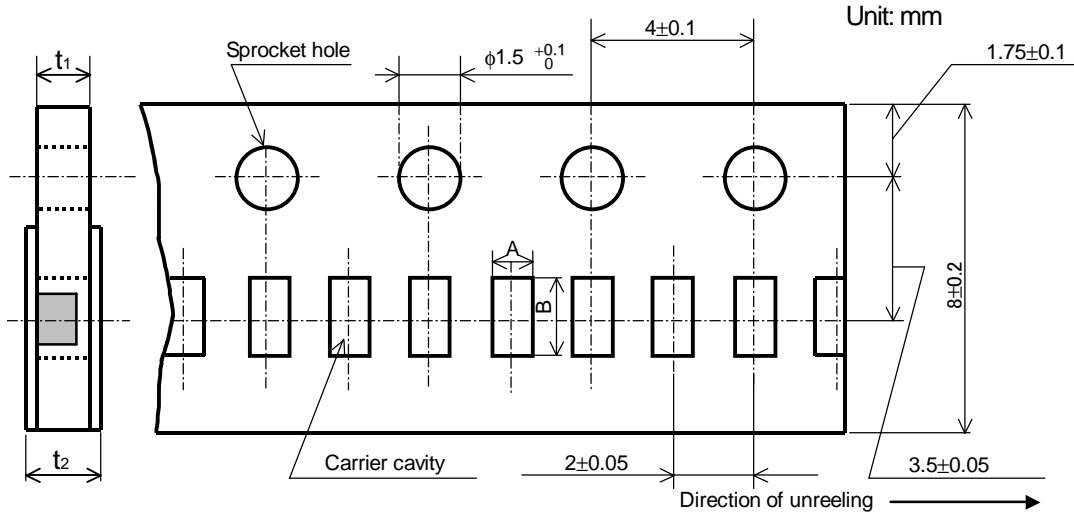

Figure-3

Table-5

Unit: mm

Style	A	B	t <sub>1</sub>	t <sub>2</sub>
RMC10	0.65 <sup>+0.05</sup> <sub>-0.10</sub>	1.15 <sup>+0.05</sup> <sub>-0.10</sub>	0.4 ± 0.05	0.5max.

#### 9.2.2 Paper taping (8mm width, 4mm pitches)

Taping dimensions shall be in accordance with Figure-4 and Table-6.

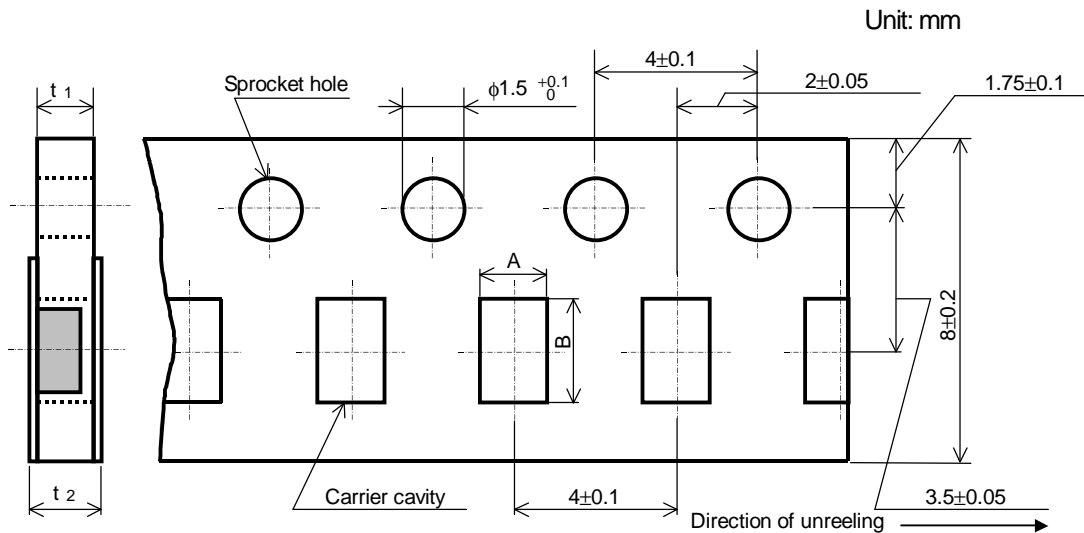

Figure-4

Table-6

Unit: mm

Style	A	B	t <sub>1</sub>	t <sub>2</sub>
RMC16	1.15 ± 0.15	1.9 ± 0.2	0.6 ± 0.1	0.8max.
RMC20	1.65 ± 0.15	2.5 ± 0.2	0.8 ± 0.1	1.0max.
RMC32	2.00 ± 0.15	3.6 ± 0.2		

9.2.3 Embossed tapping dimensions shall be in accordance with Figure-5 and Table-7.

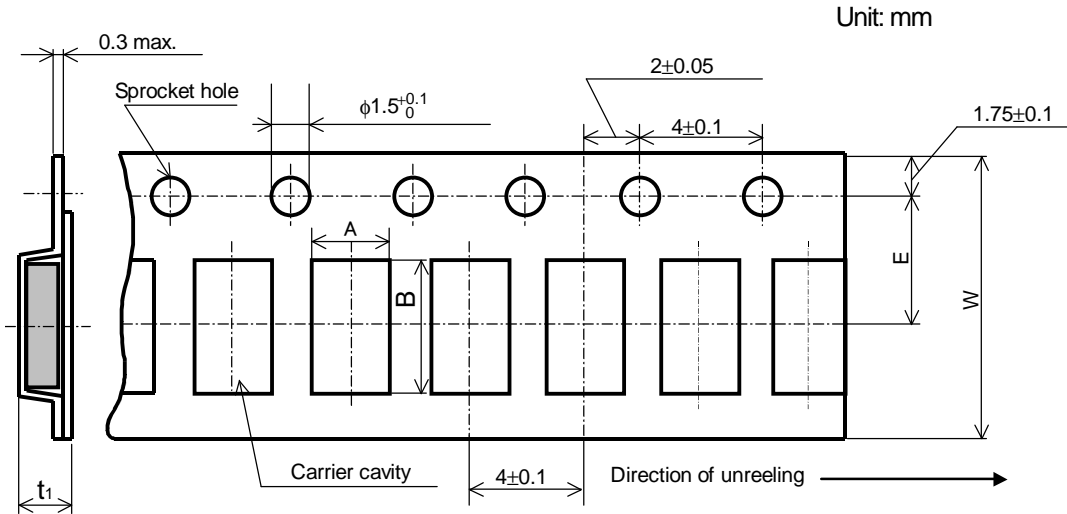

Figure-5

Table-7

Unit: mm

Style	A	B	W	E	$t_1$
RMC35	$2.85 \pm 0.20$	$3.5 \pm 0.2$	$8.0 \pm 0.3$	$3.5 \pm 0.05$	$1.0 \pm 0.2$

- 1). The cover tapes shall not cover the sprocket holes.
- 2). Tapes in adjacent layers shall not stick together in the packing.
- 3). Components shall not stick to the carrier tape or to the cover tape.
- 4). Pitch tolerance over any 10 pitches  $\pm 0.2\text{mm}$ .
- 5). The peel strength of the top cover tape shall be within 0.1N to 0.5N on the test method as shown in the following RMC10, 16, 20, 32: Figure-6, RMC35: Figure-7.
- 6). When the tape is bent with the minimum radius for 25 mm, the tape shall not be damaged and the components shall maintain their position and orientation in the tape.
- 7). In no case shall there be two or more consecutive components missing.  
The maximum number of missing components shall be one or 0.1%, whichever is greater.
- 8). The resistors shall be faced to upward at the over coating side in the carrier cavity.

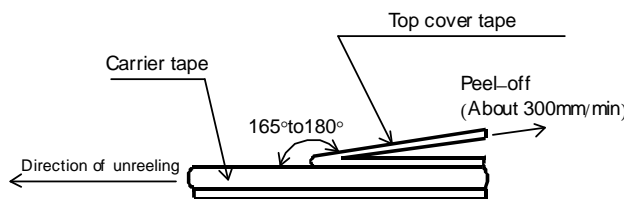

Figure-6

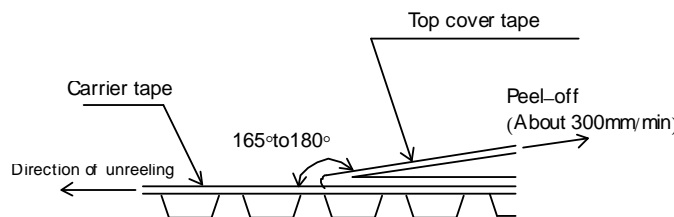

Figure-7

### 9.3 Reel dimension

Reel dimensions shall be in accordance with the following Figure-8 and Table-8.

Plastic reel (Based on EIAJ ET-7200C)

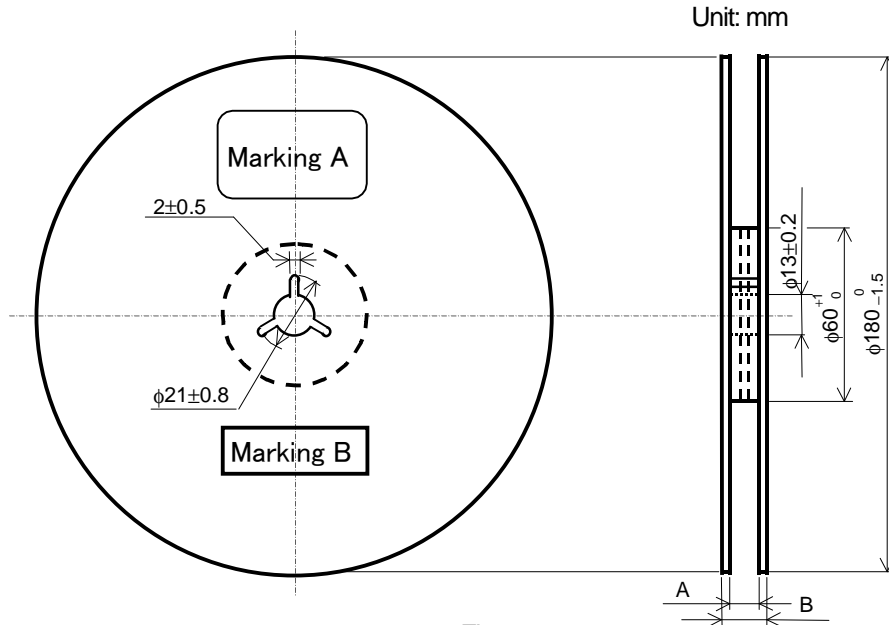

Figure-8

Table-8

Unit: mm

Style	A	B	Note
RMC 10, 16, 20, 32, 35	9 <sup>+1.0</sup> / <sub>0</sub>	11.4±1.0	Injection molding
		13±1.0	Vacuum forming

Note: Marking label shall be marked on a place of Marking A or two place of marking A and B.

### 9.4 Leader and trailer tape.

(Example)

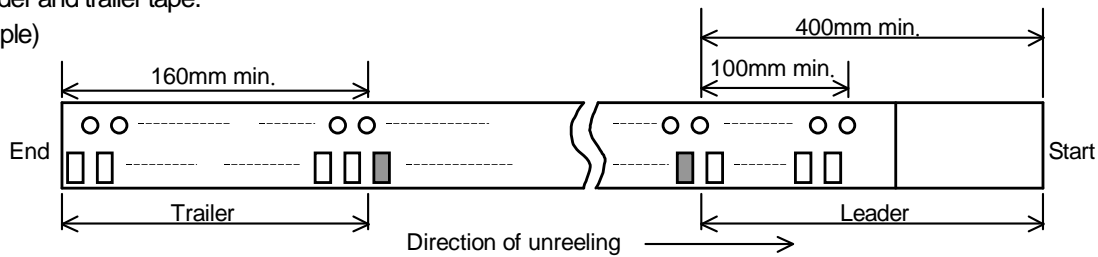

Figure-9

## 10. Marking on package

The label of a minimum package shall be legibly marked with follows.

### 10.1 Marking A

#### (1) Classification

(Style, Temperature coefficient of resistance, Rated resistance, Tolerance on rated resistance, Packaging form)

#### (2) Quantity (3) Lot number (4) Manufacturer's name or trade mark (5) Others

### 10.2 Marking B (KAMAYA Control label)

## X-ON Electronics

Largest Supplier of Electrical and Electronic Components

*Click to view similar products for [Thick Film Resistors - SMD category](#):*

*Click to view products by [Kamaya manufacturer](#):*

Other Similar products are found below :

[CR-05FL7--150R](#) [CR-05FL7--19K6](#) [CR-05FL7--243R](#) [CR-05FL7--40K2](#) [CR-05FL7--698K](#) [CR-12FP4--324R](#) [CR-12JP4--680R](#)  
[M55342K06B1E78RS3](#) [M55342K06B6E19RWL](#) [M55342K06B6E81RS3](#) [M55342M05B200DRWB](#) [M55342M06B4K70MS3](#) [MC0603-511-](#)  
[JTW](#) [742C083750JTR](#) [MCR01MZPF1202](#) [MCR01MZPF1601](#) [MCR01MZPF1800](#) [MCR01MZPF6201](#) [MCR01MZPF9102](#) [MCR01MZPJ113](#)  
[MCR01MZPJ121](#) [MCR01MZPJ125](#) [MCR01MZPJ751](#) [MCR03EZHZ103](#) [MCR03EZPF2004](#) [MCR03EZPJ270](#) [MCR03EZPJ821](#)  
[MCR10EZPF1102](#) [MCR18EZPJ330](#) [RC0603F1473CS](#) [RC0603F150CS](#) [RC1005F1152CS](#) [RC1005F1182CS](#) [RC1005F1372CS](#)  
[RC1005F183CS](#) [RC1005F1911CS](#) [RC1005F1912CS](#) [RC1005F203CS](#) [RC1005F2052CS](#) [RC1005F241CS](#) [RC1005F2431CS](#)  
[RC1005F3011CS](#) [RC1005F303CS](#) [RC1005F4321CS](#) [RC1005F4642CS](#) [RC1005F471CS](#) [RC1005F4751CS](#) [RC1005F5621CS](#)  
[RC1005F6041CS](#) [RC1005J106CS](#)