

Data sheet

Title: FIXED THICK FILM CHIP RESISTORS;
RECTANGULAR TYPE & HIGH POWER

Style: RMCH10,16,20,32,35

AEC-Q200 qualified

RoHS COMPLIANCE ITEM

Halogen and Antimony Free

Note: •Stock conditions

Temperature: +5°C ~ +35°C

Relative humidity: 25% ~ 75%

The period of guarantee: Within 2 year from shipment by the company.
Solderability shall be satisfied.

- Product specification contained in this data sheet are subject to change at any time without notice
- If you have any questions or a Purchasing Specification for any quality Agreement is necessary, please contact our sales staff.



釜屋電機株式會社
KAMAYA ELECTRIC CO., LTD.

Hokkaido Research Center
Approval by: T. Sannomiya
Drawing by: M. Shibuya

1. Scope

1.1 This data sheet covers the detail requirements for fixed thick film chip resistors; rectangular type & high power, style of RMCH10,16,20,32,35

1.2 Applicable documents

JIS C 5201-1: 2011, JIS C 5201-8: 2014, JIS C 5201-8-1: 2014
 IEC60115-1: 2008, IEC60115-8: 2009, IEC60115-8-1: 2014
 EIAJ RC-2134C-2010

2. Classification

Type designation shall be the following form.

(Example) 1)

| | | | | | |
|-------|----|----|-----|---|----|
| RMCH | 16 | K- | 123 | J | TP |
| 1 | 2 | 3 | 4 | 5 | 6 |
| ----- | | | | | |
| Style | | | | | |

1 Fixed thick film chip resistors; rectangular type & high power

2 Rated dissipation and / or dimension

3 Temperature coefficient of resistance

| | |
|---------|---|
| K | $\pm 100 \times 10^{-6} / ^\circ\text{C}$ |
| -(Dash) | Standard |

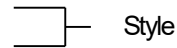

4 Rated resistance

| | |
|------|--|
| 123 | E24 Series, 3 digit, Ex. 123--> 12k Ω , |
| 1000 | E96 Series, 4 digit, Ex. 1000-->100 Ω 1022--> 10.2k Ω |

5 Tolerance on rated resistance

| | |
|---|-------------|
| D | $\pm 0.5\%$ |
| F | $\pm 1\%$ |
| J | $\pm 5\%$ |

6 Packaging form

| | |
|----|----------------------|
| B | Bulk (loose package) |
| TH | Paper taping |
| TP | |
| TE | Embossed taping |

3. Rating

3.1 The ratings shall be in accordance with Table-1.

Table-1

| Style | Rated dissipation (W) | Temperature coefficient of resistance ($10^6 / ^\circ\text{C}$) | | Rated resistance range (Ω) | Preferred number series for resistors | Tolerance on rated resistance |
|--------|-----------------------|---|-----------|-------------------------------------|---------------------------------------|---------------------------------|
| RMCH10 | 0.125 | K | ± 100 | 10~1M | E24, 96 | D($\pm 0.5\%$),F($\pm 1\%$) |
| | | Standard | ± 200 | 1~9.76 | | |
| | | K | ± 100 | 10~1M | E24 | J($\pm 5\%$) |
| | | Standard | ± 200 | 1~9.1 | | |
| RMCH16 | 0.25 | K | ± 100 | 10~1M | E24, 96 | D($\pm 0.5\%$),F($\pm 1\%$) |
| | | Standard | ± 200 | 1~9.76 | | |
| | | K | ± 100 | 10~1M | E24 | J($\pm 5\%$) |
| | | Standard | ± 200 | 1~9.1 | | |
| RMCH20 | 0.33 | K | ± 100 | 10~1M | E24, 96 | D($\pm 0.5\%$),F($\pm 1\%$) |
| | | Standard | ± 200 | 1~9.76 | | |
| | | K | ± 100 | 10~1M | E24 | J($\pm 5\%$) |
| | | Standard | ± 200 | 1~9.1 | | |
| RMCH32 | 0.5 | K | ± 100 | 10~1M | E24, 96 | D($\pm 0.5\%$),F($\pm 1\%$) |
| | | Standard | ± 200 | 1~9.76 | | |
| | | K | ± 100 | 10~1M | E24 | J($\pm 5\%$) |
| | | Standard | ± 200 | 1~9.1 | | |
| RMCH35 | 0.75 | K | ± 100 | 10~1M | E24, 96 | D($\pm 0.5\%$),F($\pm 1\%$) |
| | | Standard | ± 200 | 1~9.76 | | |
| | | K | ± 200 | 10~1M | E24 | J($\pm 5\%$) |
| | | Standard | ± 200 | 1~9.1 | | |

| Style | Limiting element voltage (V) | Insulation voltage (V) | Category temperature range ($^\circ\text{C}$) |
|--------|------------------------------|------------------------|---|
| RMCH10 | 50 | 100 | -55~+155 |
| RMCH16 | 150 | 150 | |
| RMCH20 | 200 | 500 | |
| RMCH32 | | | |
| RMCH35 | | | |

3.2 Climatic category

55/155/56

Lower category temperature - 55 $^\circ\text{C}$
 Upper category temperature +155 $^\circ\text{C}$
 Duration of the damp heat, steady state test 56days

3.3 Stability class

2%

Limits for change of resistance:
 -for long-term tests $\pm(2\%+0.1\Omega)$
 -for short-term tests $\pm(0.5\%+0.05\Omega)$

3.4 Derating

The derated values of dissipation at temperature in excess of 70 °C shall be as indicated by the following curve.

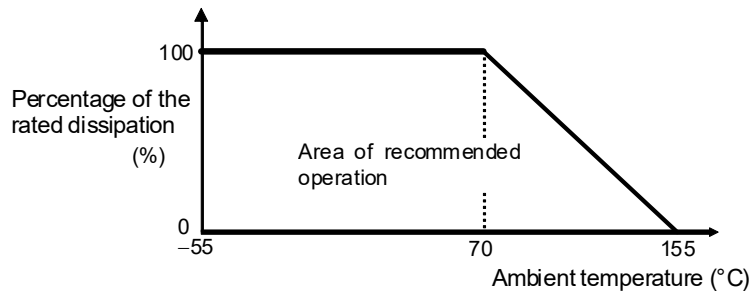

Figure-1 Derating curve

3.5 Rated voltage

d. c. or a. c. r. m. s. voltage calculated from the square root of the product of the rated resistance and the rated dissipation.

$$E = \sqrt{P \cdot R}$$

E : Rated voltage (V)

P : Rated dissipation (W)

R : Rated resistance (Ω)

Limiting element voltage can only be applied to resistors when the resistance value is equal to or higher than the critical resistance value.

At high value of resistance, the rated voltage may not be applicable.

4. Packaging form

The standard packaging form shall be in accordance with Table-2.

Table-2

| Symbol | Packaging form | | Standard packaging quantity / units | Application |
|--------|----------------------|------------------------|-------------------------------------|--------------------|
| B | Bulk (loose package) | | 1,000 pcs. | RMCH10,16,20,32,35 |
| TH | Paper taping | 8mm width, 2mm pitches | 10,000 pcs. | RMCH10 |
| TP | Paper taping | 8mm width, 4mm pitches | 5,000 pcs. | RMCH16,20,32 |
| TE | Embossed taping | 8mm width, 4mm pitches | 4,000 pcs. | RMCH35 |

5. Dimensions

5.1 The resistor shall be of the design and physical dimensions in accordance with Figure-2 and Table-3.

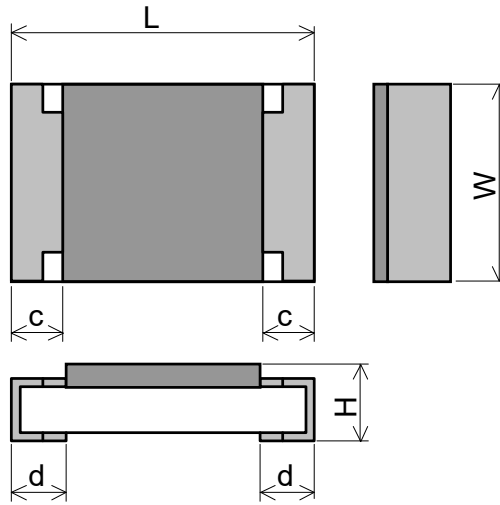

Figure-2

Table-3

Unit : mm

| Style | L | W | H | c | d |
|--------|----------|---------------------------------------|-----------|----------|--|
| RMCH10 | 1.0±0.05 | 0.5±0.05 | 0.35±0.05 | 0.2±0.15 | 0.25 ^{+0.05} _{-0.10} |
| RMCH16 | 1.6±0.1 | 0.8 ^{+0.15} _{-0.05} | 0.45±0.10 | 0.3±0.2 | 0.3±0.1 |
| RMCH20 | 2.0±0.1 | 1.25±0.10 | 0.55±0.10 | 0.3±0.2 | 0.4±0.2 |
| RMCH32 | 3.1±0.1 | 1.6±0.15 | 0.55±0.10 | 0.3±0.2 | 0.5±0.25 |
| RMCH35 | 3.1±0.15 | 2.5±0.15 | 0.55±0.15 | 0.3±0.2 | 0.5±0.25 |

5.2 Net weight (Reference)

| Style | Net weight(mg) |
|--------|----------------|
| RMCH10 | 0.6 |
| RMCH16 | 2 |
| RMCH20 | 5 |
| RMCH32 | 9 |
| RMCH35 | 16 |

6. Marking

The nominal resistance shall be marked in 3 digits or 4 digits and marked on over coat side.

- E24 series: 3 digits, E96 series: 4 digits

In case of the resistance value that E96 overlaps with E24, It is marked by either.

The Rated resistance of RMCH10 should not be marked.

The Rated resistance of RMCH16 should not be marked in 4 digits (E96).

| Marking example | Contents | Application |
|-----------------|-----------------------------------|----------------------------------|
| 123 | 12×10 ³ [Ω] → 12 [kΩ] | RMCH16,20,32,35 |
| 2R2 | 2.2 [Ω] | Less than 10Ω of RMCH16,20,32,35 |
| 5623 | 562×10 ³ [Ω] → 562[kΩ] | RMCH20,32,35 |
| 12R7 | 12.7 [Ω] | RMCH20,32,35 |

Table-4(2)

| No | Test items | Condition of test (JIS C 5201-1) | Performance requirements |
|----|--|---|--|
| 6 | Mounting Bound strength of the end face plating Final measurements | Sub-clause 4.31 Substrate material: Epoxide woven glass Sub-clause 4.33 Bent value: 3 mm Resistance Sub-clause 4.33.6 Visual examination | $\Delta R \leq \pm (0.5\%+0.05\Omega)$ No visible damage |
| 7 | Resistance to soldering heat Component solvent resistance | Sub-clause 4.18 Solder temperature: $260\text{ }^\circ\text{C} \pm 5\text{ }^\circ\text{C}$ Immersion time: $10\text{ s} \pm 0.5\text{ s}$ Visual examination Resistance Sub-clause 4.29 Solvent: 2-propanol Solvent temperature: $23\text{ }^\circ\text{C} \pm 5\text{ }^\circ\text{C}$ Method 2 Recovery: 48 h Visual examination Resistance | As in 4.18.3.4 No sign of damage such as cracks. $\Delta R \leq \pm (0.5\%+0.05\Omega)$ No visible damage $\Delta R \leq \pm (0.5\%+0.05\Omega)$ |
| 8 | Mounting Adhesion Rapid change temperature | Sub-clause 4.31 Substrate material: Epoxide woven glass Sub-clause 4.32 Force: 5 N Duration: $10\text{ s} \pm 1\text{ s}$ Visual examination Sub-clause 4.19 Lower category temperature: $-55\text{ }^\circ\text{C}$ Upper category temperature: $+155\text{ }^\circ\text{C}$ Duration of exposure at each temperature: 30 min. Number of cycles: 5 cycles. Visual examination Resistance | No visible damage No visible damage $\Delta R \leq \pm(0.5\%+0.05\Omega)$ |

Table-4(3)

| No | Test items | Condition of test (JIS C 5201-1) | Performance requirements |
|----|---|---|--|
| 9 | Climatic sequence -Dry heat -Damp heat, cycle (12+12hour cycle) First cycle -Cold -Damp heat, cycle (12+12hour cycle) Remaining cycle -D.C. load | Sub-clause 4.23 Sub-clause 4.23.2 Test temperature: +155 °C Duration: 16 h Sub-clause 4.23.3 Test method: 2 Test temperature: 55 °C [Severity(2)] Sub-clause 4.23.4 Test temperature -55 °C Duration: 2h Sub-clause 4.23.6 Test method: 2 Test temperature: 55 °C [Severity (2)] Number of cycles: 5 cycles Sub-clause 4.23.7 The applied voltage shall be the rated voltage or the limiting element voltage whichever is the smaller. Duration: 1 min. Visual examination Resistance | No visible damage $\Delta R \leq \pm (2\%+0.1\Omega)$ |
| 10 | Mounting Endurance at 70 °C | Sub-clause 4.31 Substrate material: Epoxide woven glass Sub-clause 4.25.1 Ambient temperature: 70 °C \pm 2 °C Duration: 1000 h The voltage shall be applied in cycles of 1.5 h on and 0.5 h off. The applied voltage shall be the rated voltage or the limiting element voltage whichever is the smaller. Examination at 48 h , 500 h and 1000 h: Visual examination Resistance | No visible damage $\Delta R \leq \pm (2\%+0.1\Omega)$ |
| 11 | Mounting Variation of resistance with temperature | Sub-clause 4.31 Substrate material: Epoxide woven glass Sub-clause 4.8 -55 °C / +20 °C +20 °C / +155°C | As in Table-1 |

Table-4(4)

| No | Test items | Condition of test (JIS C 5201-1) | Performance requirements |
|----|--|---|---|
| 12 | Mounting Damp heat, steady state | Sub-clause 4.31 Substrate material: Epoxide woven glass Sub-clause 4.24 Ambient temperature: 40 °C ± 2 °C Relative humidity : 93 ± ₃ % a) 1st group: without voltage applied. b) 2nd group: The d. c. voltage shall be applied continuously. The voltage shall be accordance with Sub-clause 4.24.2.1 b). without polarizing voltage [4.24.2.1, c)] Visual examination Resistance | No visible damage Legible marking $\Delta R \leq \pm (2\%+0.1\Omega)$ |
| 13 | Dimensions (detail) Mounting Endurance at upper category temperature | Sub-clause 4.4.3 Sub-clause 4.31 Substrate material: Epoxide woven glass Sub-clause 4.25.3 Ambient temperature: 155 °C ± 2 °C Duration: 1000 h Examination at 48 h, 500 h and 1000 h: Visual examination Resistance | As in Table-3 No visible damage $\Delta R \leq \pm (2\%+0.1\Omega)$ |

8. Taping

8.1 Applicable documents JIS C 0806-3: 2014, EIAJ ET-7200C: 2010

8.2 Taping dimensions

8.2.1 Paper taping (8mm width, 2mm pitches)

Taping dimensions shall be in accordance with Figure-3 and Table-5.

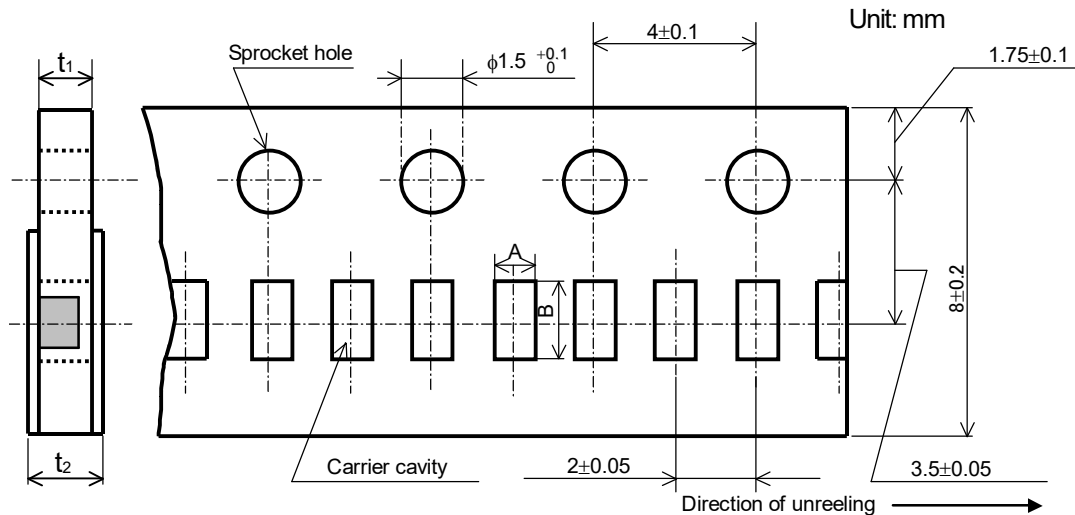

Figure-3

Table-5

| Style | A | B | t_1 | t_2 |
|--------|------------------------|------------------------|----------------|---------|
| RMCH10 | $0.65^{+0.05}_{-0.10}$ | $1.15^{+0.05}_{-0.10}$ | 0.4 ± 0.05 | 0.5max. |

8.2.2 Paper taping (8mm width, 4mm pitches)

Taping dimensions shall be in accordance with Figure-4 and Table-6.

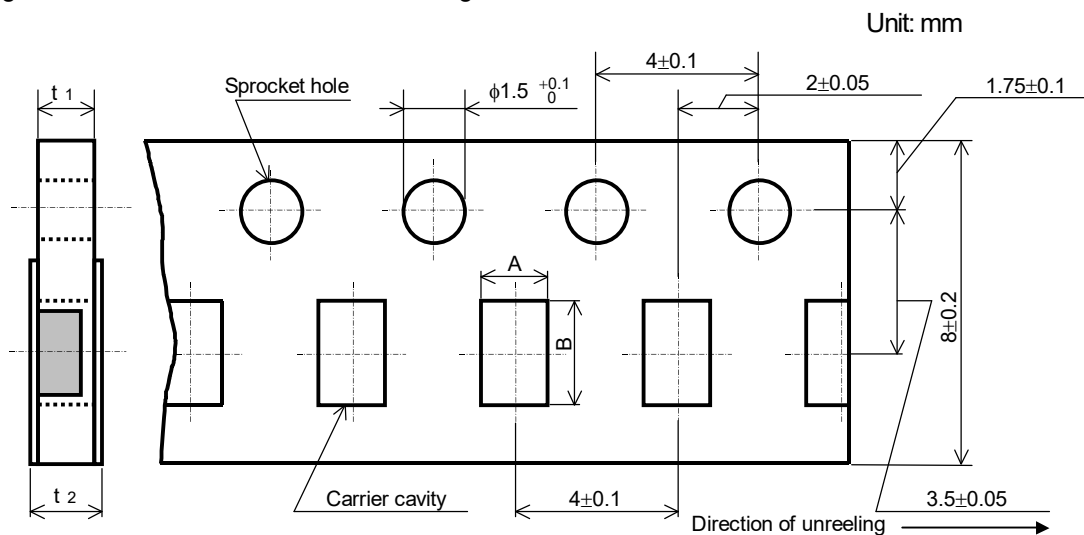

Figure-4

Table-6

| Style | A | B | t_1 | t_2 |
|--------|-----------------|---------------|---------------|---------|
| RMCH16 | 1.15 ± 0.15 | 1.9 ± 0.2 | 0.6 ± 0.1 | 0.8max. |
| RMCH20 | 1.65 ± 0.15 | 2.5 ± 0.2 | 0.8 ± 0.1 | 1.0max. |
| RMCH32 | 2.00 ± 0.15 | 3.6 ± 0.2 | | |

8.2.3 Embossed tapping dimensions shall be in accordance with Figure-5 and Table-7.

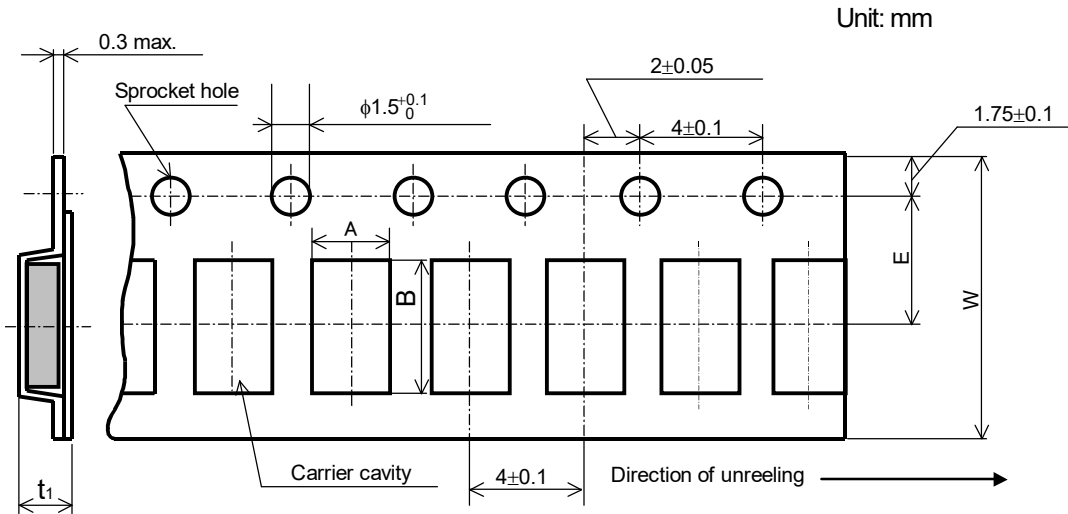

Figure-5

Table-7

Unit: mm

| Style | A | B | W | E | t ₁ |
|--------|-----------|---------|---------|----------|----------------|
| RMCH35 | 2.85±0.20 | 3.5±0.2 | 8.0±0.3 | 3.5±0.05 | 1.0±0.2 |

- 1). The cover tapes shall not cover the sprocket holes.
- 2). Tapes in adjacent layers shall not stick together in the packing.
- 3). Components shall not stick to the carrier tape or to the cover tape.
- 4). Pitch tolerance over any 10 pitches ±0.2mm.
- 5). The peel strength of the top cover tape shall be within 0.1N to 0.5N on the test method as shown in the following RMCH10,16,20,32: Figure-6, RMCH35: Figure-7.
- 6). When the tape is bent with the minimum radius for 25 mm, the tape shall not be damaged and the components shall maintain their position and orientation in the tape.
- 7). In no case shall there be two or more consecutive components missing.
The maximum number of missing components shall be one or 0.1%, whichever is greater.
- 8). The resistors shall be faced to upward at the over coating side in the carrier cavity.

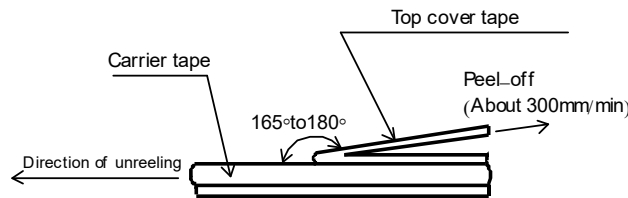

Figure-6

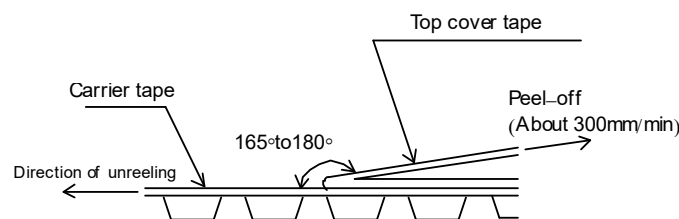

Figure-7

8.3 Reel dimension

Reel dimensions shall be in accordance with the following Figure-8 and Table-8.

Plastic reel (Based on EIAJ ET-7200C)

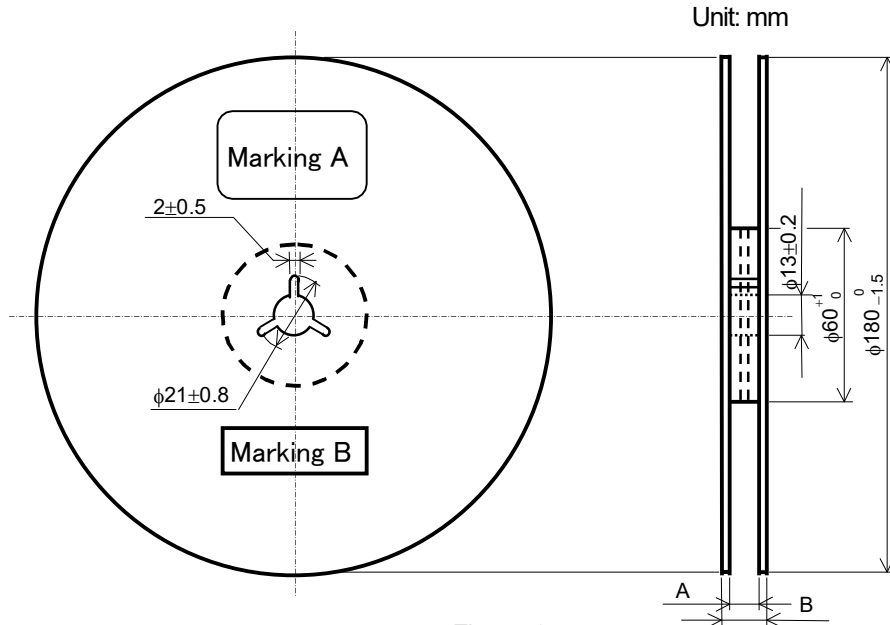

Figure-8

Table-8

Unit: mm

| Style | A | B | Note |
|--------------------|--------------------------------|----------|-------------------|
| RMCH10,16,20,32,35 | 9 ^{+1.0} ₀ | 11.4±1.0 | Injection molding |
| | | 13±1.0 | Vacuum forming |

Note: Marking label shall be marked on a place of Marking A or two place of marking A and B.

8.4 Leader and trailer tape.

(Example)

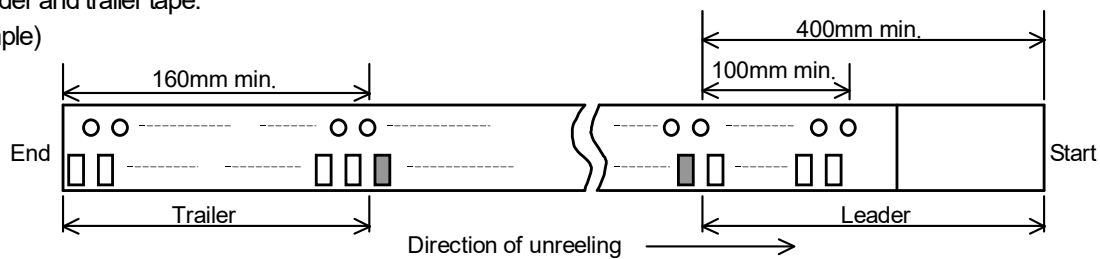

Figure-9

9. Marking on package

The label of a minimum package shall be legibly marked with follows.

9.1 Marking A

(1) Classification

(Style, Temperature coefficient of resistance, Rated resistance, Tolerance on rated resistance, Packaging form)

(2) Quantity (3) Lot number (4) Manufacturer's name or trade mark (5) Others

9.2 Marking B (KAMAYA Control label)

X-ON Electronics

Largest Supplier of Electrical and Electronic Components

Click to view similar products for [Thick Film Resistors - SMD category](#):

Click to view products by [Kamaya manufacturer](#):

Other Similar products are found below :

[CR-05FL7--150R](#) [CR-05FL7--19K6](#) [CR-05FL7--243R](#) [CR-05FL7--40K2](#) [CR-05FL7--698K](#) [CR-12FP4--324R](#) [CR-12JP4--680R](#)

[M55342K06B6E19RWL](#) [M55342K06B6E81RS3](#) [M55342M05B200DRWB](#) [M55342M06B4K70MS3](#) [MC0603-511-JTW](#) [742C083750JTR](#)

[MCR01MZPF1202](#) [MCR01MZPF1601](#) [MCR01MZPF1800](#) [MCR01MZPF6201](#) [MCR01MZPF9102](#) [MCR01MZPJ113](#) [MCR01MZPJ121](#)

[MCR01MZPJ125](#) [MCR01MZPJ751](#) [MCR03EZHJ103](#) [MCR03EZPFX2004](#) [MCR03EZPJ270](#) [MCR03EZPJ821](#) [MCR10EZPF1102](#)

[MCR18EZPJ330](#) [RC0603F1473CS](#) [RC0603F150CS](#) [RC1005F1152CS](#) [RC1005F1182CS](#) [RC1005F1372CS](#) [RC1005F183CS](#)

[RC1005F1911CS](#) [RC1005F1912CS](#) [RC1005F203CS](#) [RC1005F2052CS](#) [RC1005F241CS](#) [RC1005F2431CS](#) [RC1005F3011CS](#)

[RC1005F303CS](#) [RC1005F4321CS](#) [RC1005F4642CS](#) [RC1005F471CS](#) [RC1005F4751CS](#) [RC1005F5621CS](#) [RC1005F6041CS](#)

[RC1005J106CS](#) [RC1005J121CS](#)