

BT134W Series
2A TRIACs
4 Quadrants

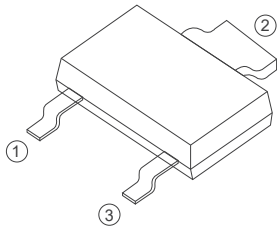

SOT-223-2

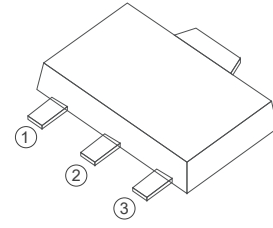

SOT-89

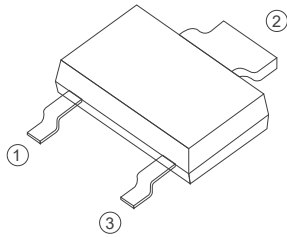

SOT-89-2L

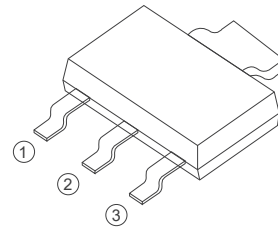

SOT-223-3

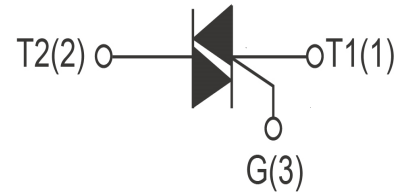

FEATURES

> $I_T(RMS): 2A$ > $V_{GT}: 1.2V$ > $V_{DRM} V_{RRM}: 600V$

APPLICATIONS

Washing machine, vacuums, massager, solid state relay, AC Motor speed regulation and so on.

Absolute Maximum Ratings (T_J=25°C unless otherwise specified)

Symbol	Parameter	Conditions	Ratings	Unit
VDRM/VRRM	Repetitive Peak Off-State Voltage		600	V
IT(RMS)	R.M.S On-State Current	T _c =110°C	2	A
ITSM	Surge On-State Current	T _p =10ms	20	
I ² t	I ² t for fusing	T _p =10ms	2.6	A ² s
PG(AV)	Average Gate Power Dissipation	T _J =125°C	0.5	W
IGM	Peak Gate Current	t _p =20us T _J =125°C	2	A
T _J	Operating Junction Temperature		~40~125	°C
TSTG	Storage Temperature		~40~150	

Electrical Characteristics (T_J=25°C unless otherwise specified)

Symbol	Parameter	Test Conditions	Value	Unit	
IDRM	Repetitive Peak Off-State Current	T _J =25°C	≤10	uA	
		T _J =110°C	≤200	uA	
IRRM	Repetitive Peak Reverse Current	T _J =25°C	≤10	uA	
		T _J =110°C	≤200	uA	
VTM	Forward "on" voltage	I _T =4A t _p =380us	≤1.5	V	
VGD	Gate non-trigger voltage	V _D =V _{DRM} , T _J =110°C	≥0.2	V	
IH	Holding current	V _D =12V ,I _{GT} =0.1A	I,II,III	≤5	mA
			IV	≤10	mA
VGT	Gate trigger voltage	V _D =12V	≤1.2	V	
IGT	Gate trigger current	V _D =12V	I,II,III	≤3	mA
			IV	≤7	mA
di/dt	Critical-rate of rise of commutation current.	I _T =4A I _G =0.2A, dI _G /dt=0.2A/us	I,II,III	≥50	A /us
			IV	≥10	A /us
dv/dt	Critical-rate of rise of commutation voltage	T _J =110°C V _D =2/3V _{DRM}	≥30	V/us	

FIG1

FIG.1: Maximum power dissipation versus RMS on-state current

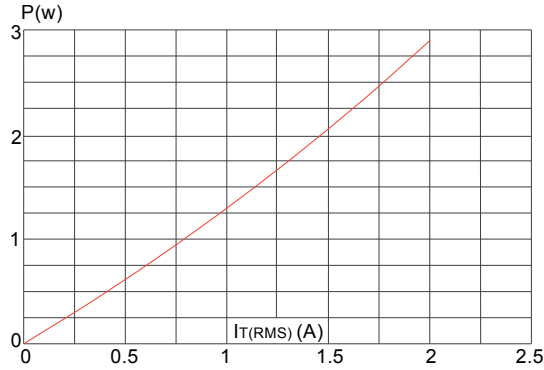

FIG2

FIG.2: RMS on-state current versus case temperature

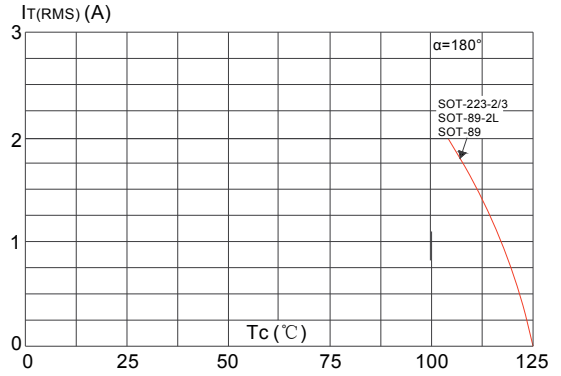

FIG3

Surge peak on-state current versus number of cycles

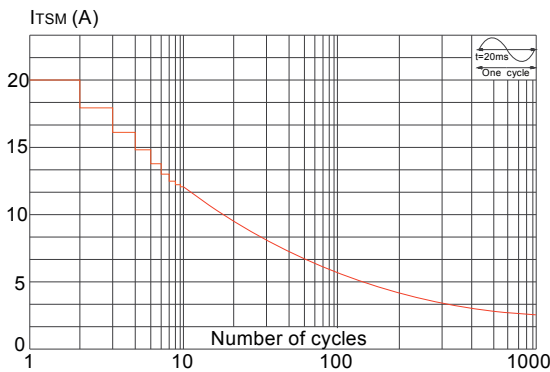

FIG4

On-state characteristics (maximum values)

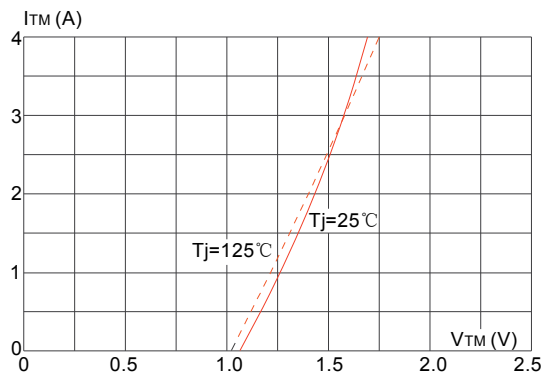

FIG5

Non-repetitive surge peak on-state current for a sinusoidal pulse with width $t_p < 20\text{ms}$, and corresponding value of I^2t ($dI/dt < 100\text{A}/\mu\text{s}$)

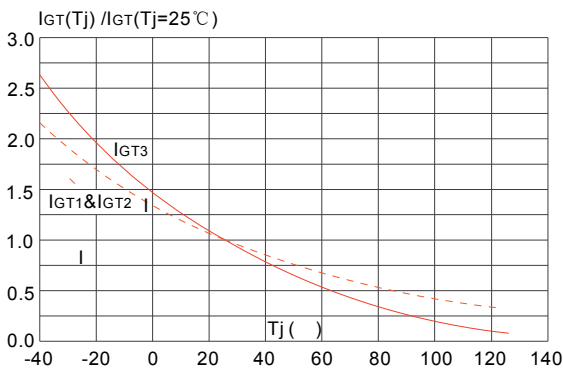
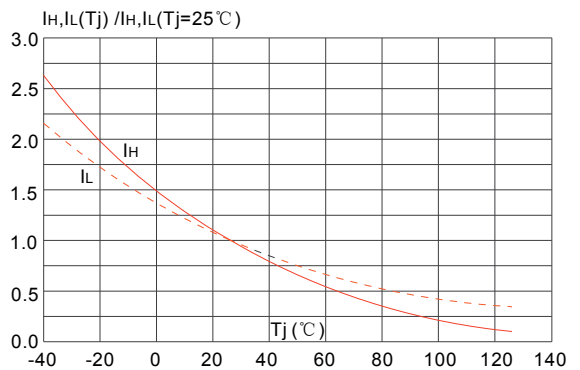
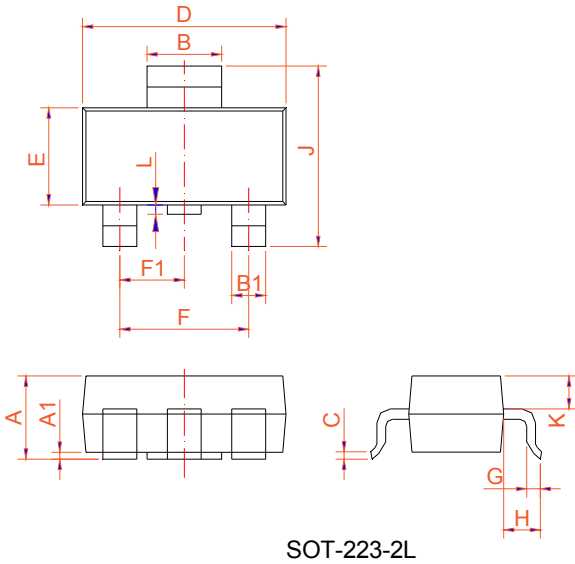

FIG6

FIG.6: Relative variations of gate trigger current, holding current and latching current versus junction temperature



PACKAGE MECHANICAL DATA



Ref.	Dimensions					
	Millimeters			Inches		
	Min.	Typ.	Max.	Min.	Typ.	Max.
A	1.5	1.6	1.8	0.059	0.063	0.071
A1	0.01	0.06	0.10	0.001	0.002	0.004
B	2.9	3.0	3.1	0.114	0.118	0.122
B1	0.6	0.7	0.8	0.024	0.028	0.031
C	0.22	0.26	0.32	0.009	0.010	0.013
D	6.3	6.5	6.7	0.248	0.256	0.264
E	3.3	3.5	3.7	0.130	0.138	0.146
F		4.6			0.181	
F1		2.3			0.091	
G	0.7	0.9	1.1	0.028	0.035	0.043
H	1.5	1.75	2	0.059	0.069	0.079
J	6.7	7.0	7.3	0.264	0.276	0.287
K		0.9			0.035	
L	0	0.1	0.2	0	0.004	0.008

Ref.	Dimensions					
	Millimeters			Inches		
	Min.	Typ.	Max.	Min.	Typ.	Max.
A	1.3	1.4	1.5	0.051	0.055	0.059
A1	0.01	0.06	0.10	0.001	0.002	0.004
B	1.6	1.7	1.8	0.063	0.067	0.071
B1	0.3	0.4	0.5	0.012	0.016	0.020
C	0.22	0.254	0.32	0.009	0.010	0.013
D	4.75	4.95	5.15	0.187	0.195	0.203
E	2.75	2.95	3.15	0.108	0.116	0.124
F		3.0			0.118	
F1		1.5			0.059	
G	0.2	0.3	0.4	0.008	0.012	0.016
H	0.58	0.78	0.98	0.023	0.031	0.039
J	4.3	4.5	4.7	0.169	0.177	0.185
K		0.88			0.035	

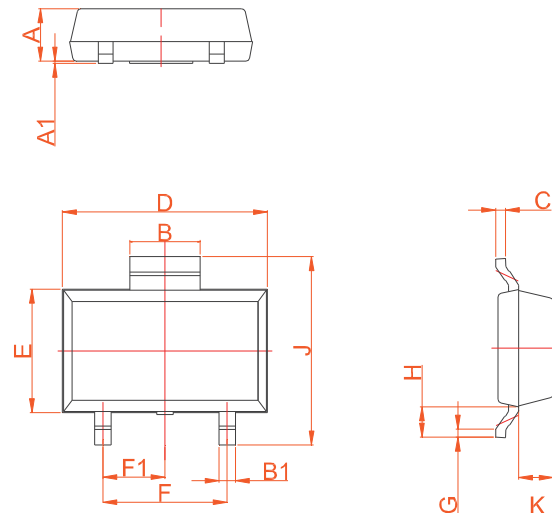

PACKAGE MECHANICAL DATA

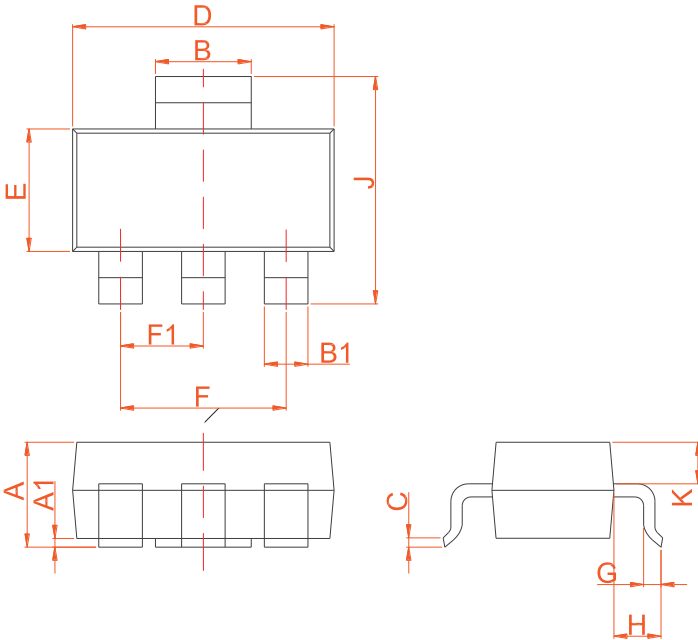

SOT-223

Ref.	Dimensions					
	Millimeters			Inches		
	Min.	Typ.	Max.	Min.	Typ.	Max.
A	1.5	1.6	1.8	0.059	0.063	0.071
A1	0	0.06	0.10	0	0.002	0.004
B	2.9	3.0	3.1	0.114	0.118	0.122
B1	0.6	0.7	0.8	0.024	0.028	0.031
C	0.22	0.26	0.32	0.009	0.010	0.013
D	6.3	6.5	6.7	0.248	0.256	0.264
E	3.3	3.5	3.7	0.130	0.138	0.146
F		4.6			0.181	
F1		2.3			0.091	
G	0.7	0.9	1.1	0.028	0.035	0.043
H	1.5	1.75	2.0	0.059	0.069	0.079
J	6.7	7.0	7.3	0.264	0.276	0.287
K	0.8	0.9	1.0	0.031	0.035	0.039

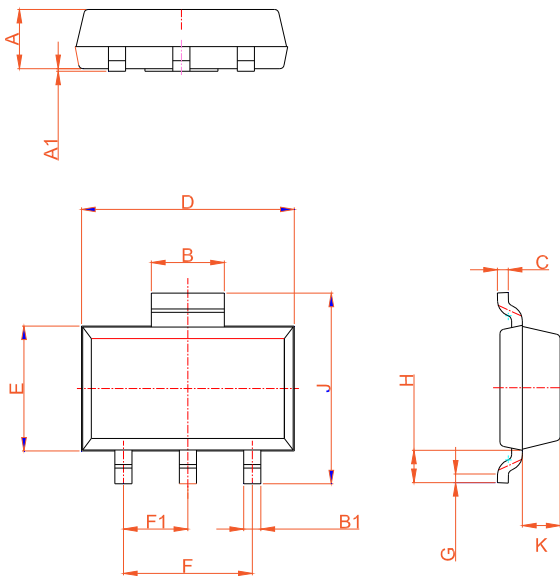

SOT-89

Ref.	Dimensions					
	Millimeters			Inches		
	Min.	Typ.	Max.	Min.	Typ.	Max.
A	1.3	1.4	1.5	0.051	0.055	0.059
A1	0.01	0.06	0.10	0.001	0.002	0.004
B	1.6	1.7	1.8	0.063	0.067	0.071
B1	0.3	0.4	0.5	0.012	0.016	0.020
C	0.22	0.254	0.32	0.009	0.010	0.013
D	4.75	4.95	5.15	0.187	0.195	0.203
E	2.75	2.95	3.15	0.108	0.116	0.124
F		3.0			0.118	
F1		1.5			0.059	
G	0.2	0.3	0.4	0.008	0.012	0.016
H	0.58	0.78	0.98	0.023	0.031	0.039
J	4.3	4.5	4.7	0.169	0.177	0.185
K		0.88			0.035	



Information furnished is believed to be accurate and reliable. However, Shenzhen HanKingyuan Electronic assumes no responsibility for the consequences of use of such information nor for any infringement of patents or other rights of third parties which may result from its use. Specifications mentioned in this publication are subject to change without notice. This publication supersedes and replaces all information previously supplied.

The KY logo is a registered trademark of Shenzhen HanKingyuan Electronic.

©2013 Shenzhen HanKingyuan Electronic - Printed in Shenzhen - All Rights Reserved

X-ON Electronics

Largest Supplier of Electrical and Electronic Components

Click to view similar products for [Triacs](#) category:

Click to view products by [Kang Yang](#) manufacturer:

Other Similar products are found below :

[BT137-600-0Q](#) [OT415Q](#) [2N6075A](#) [NTE5688](#) [BTA2008W-800D,135](#) [D31410](#) [QJ8006NH4TP](#) [QJ8010NH5TP](#) [QJ8008NH4TP](#)
[QJ8006NH4RP](#) [QJ8010RH5TP](#) [QJ8010NH4TP](#) [QJ8006LH4TP](#) [BT136-600,127](#) [BT137B-800,118](#) [BT138-800E,127](#) [BTA140-600,127](#)
[BTA208-800B,127](#) [BTA225-800B,127](#) [MAC97A6,116](#) [BTA420-800BT,127](#) [BTA201W-800E,115](#) [BTA212B-800B,118](#) [MCR100-8](#) [100-8](#)
[BT131S](#) [MCR100-6](#) [MCR100-8](#) [BT136S-800E](#) [BT151-650R](#) [BT136-800E](#) [BT138S-800E](#) [MAC97A8](#) [BT137S-800E](#) [BT169-23](#) [BT131-89-](#)
[2L](#) [MAC97A6-23-3L](#) [BT169-89-2L](#) [BT139-800E](#) [MCR100-8](#) [BT169-MS](#) [MCR100-8](#) [MCR100-6](#) [BTA408X-1000C0T,127](#) [BTA201-](#)
[800ER,116](#) [T810](#) [2P4M](#) [BT137-600E](#) [BT137-800D](#) [BT136-800E](#) [BT151](#)