

BT138 Series
12A TRIACs
4 Quadrants TRIACs

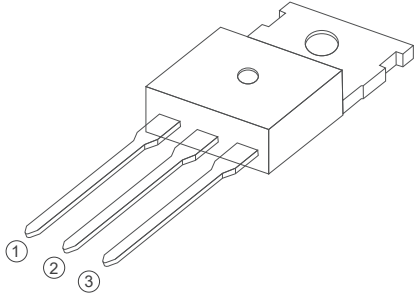

TO-220C

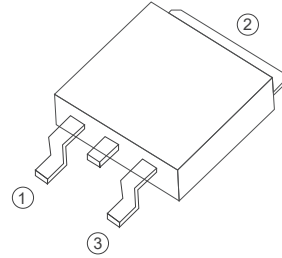

TO-252

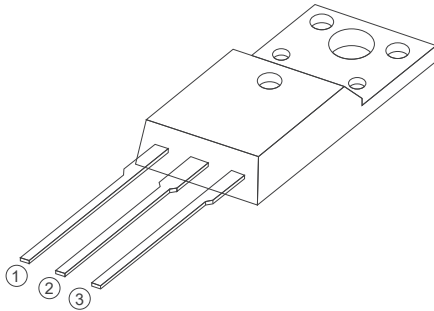

TO-220F Insulated

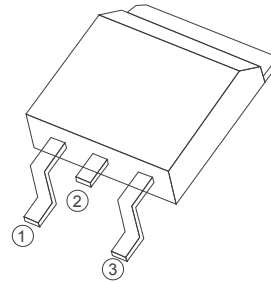

TO-263

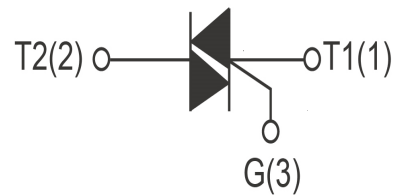

FEATURES

> IT(RMS): 12A > VGT: 1.5V > VDRM VRRM:600and800V

APPLICATIONS

Washing machine,vacuums, massager,solid state relay, AC Motor speed regulation and so on.

Absolute Maximum Ratings (T_J=25°C unless otherwise specified)

Symbol	Parameter	Conditions	Ratings	Unit
VDRM VRRM	Repetitive Peak Off-State Voltage	BT138-600	600	V
		BT138-800	800	V
IT(RMS)	R.M.S On-State Current	T _c =110°C	12	A
ITSM	Surge On-State Current	tp=16.7ms/tp=10ms	115/120	A
I ² t	I ² t for fusing	Tp=10ms	70	A ² s
PG(AV)	Average Gate Power Dissipation	T _J =125°C	1	W
IGM	Peak Gate Current	tp=20us T _J =125°C	4	A
T _J	Operating Junction Temperature		~40~125	°C
TSTG	Storage Temperature		~40~150	°C

Electrical Characteristics (T_J=25°C unless otherwise specified)

Symbol	Parameter	Test Conditions	Value				Unit
			D	E	F	G	
IDRM	Repetitive Peak Off-State Current	T _J =25°C	≤5				uA
		T _J =125°C	≤1				mA
IRRM	Repetitive Peak Reverse Current	T _J =25°C	≤5				uA
		T _J =125°C	≤1				mA
VTM	Forward "on" voltage	IT=35A tp=380us	≤1.55				V
VGT	Gate trigger voltage	VD=12V ,RL=30Ω	≤1.5				V
di/dt	Critical-rate of rise of commutation current.	T _J =125°C ,IG=2XIGT, tr ≤100ns,F=100Hz	≥50				A /us
			≥10				A /us
IGT	Gate trigger current	VD=12V RL=30Ω	≤5	≤10	≤25	≤50	mA
			≤10	≤25	≤70	≤100	mA
IH	Holding current	IT=0.2A	≤10	≤25	≤30	≤60	mA
VGD	Gate non-trigger voltage	ALL VD=VDRM T _J =125°C,RL=3.3KΩ	≥0.2				V
dv/dt	Critical-rate of rise of commutation voltage	T _J =125°C VD=2/3VDRM Gate	≥5	≥10	≥50	≥200	V/us

FIG1

Maximum power dissipation versus RMS on-state current

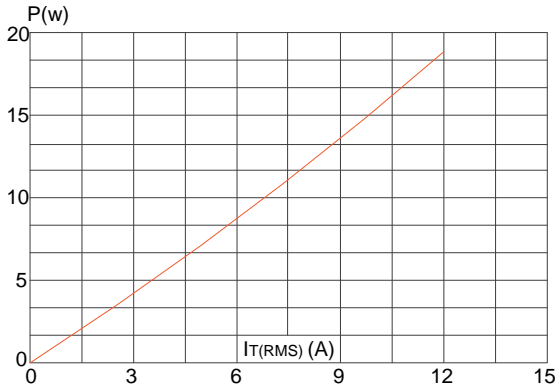

FIG2

RMS on-state current versus case temperature

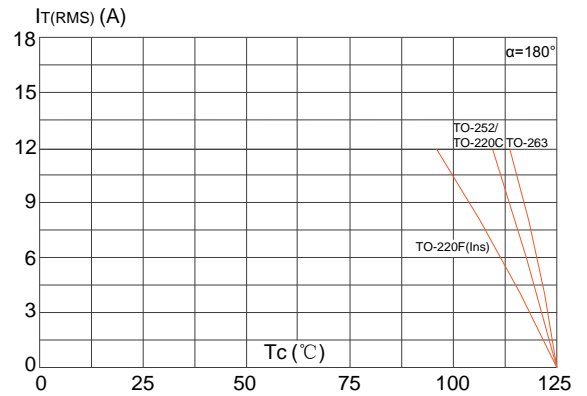

FIG3

Surge peak on-state current versus number of cycles

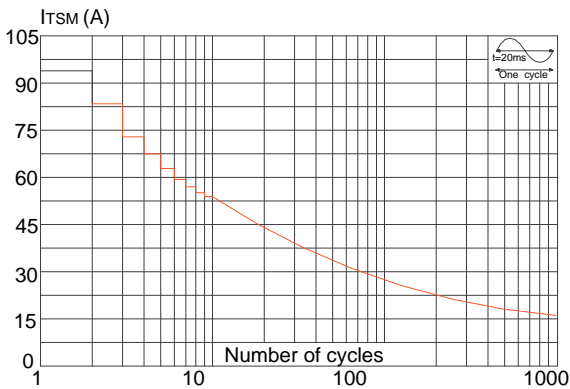

FIG4

On-state characteristics (maximum values)

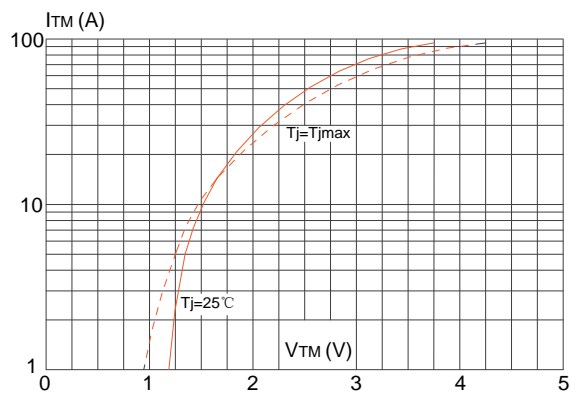

FIG5

Non-repetitive surge peak on-state current for a sinusoidal pulse with width $t_p < 20\text{ms}$, and corresponding value of I^2t ($di/dt < 100\text{A}/\mu\text{s}$)

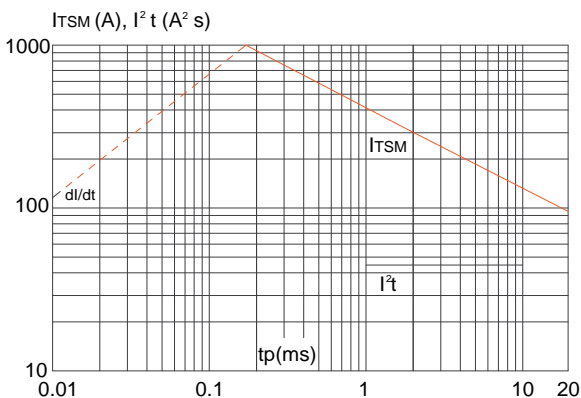

FIG6

Relative variations of gate trigger current, holding current and latching current versus junction temperature

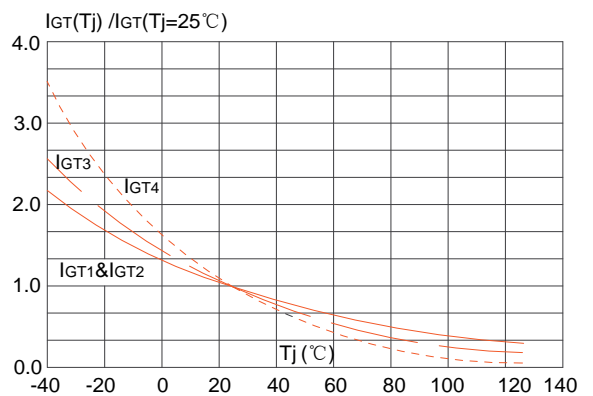

FIG7

FIG.7: Relative variations of holding current versus junction temperature

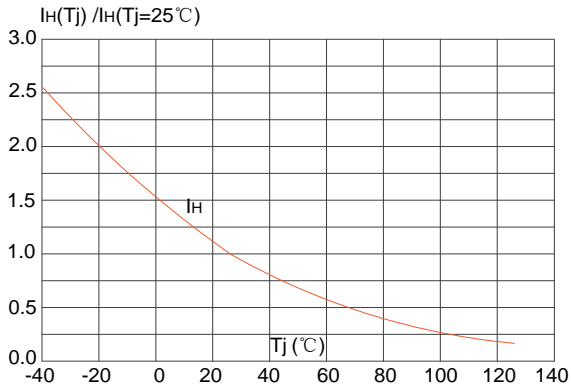
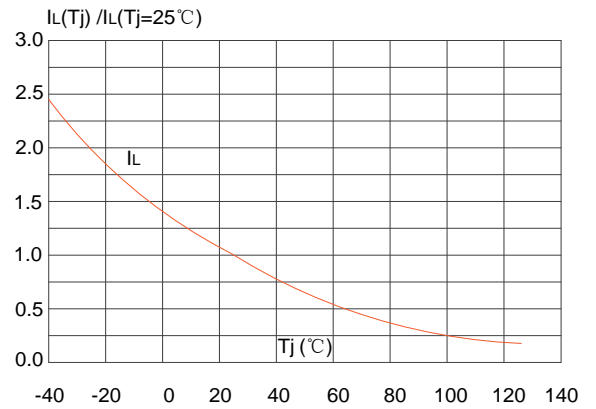
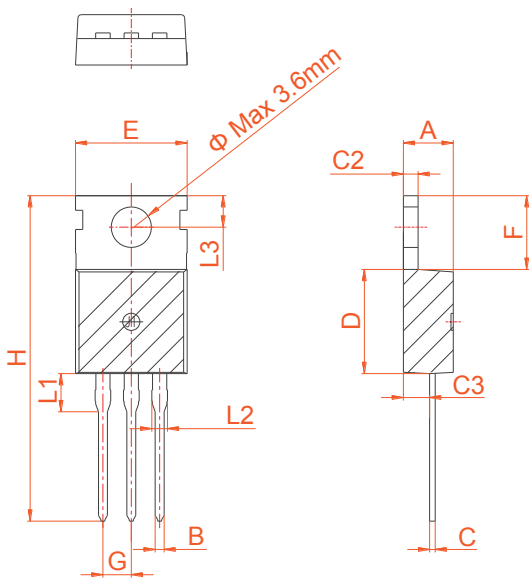

FIG8

FIG.8: Relative variations of latching current versus junction temperature



PACKAGE MECHANICAL DATA



TO-220C

Ref.	Dimensions					
	Millimeters			Inches		
	Min.	Typ.	Max.	Min.	Typ.	Max.
A	4.40		4.60	0.173		0.181
B	0.70		0.90	0.028		0.035
C	0.45		0.60	0.018		0.024
C2	1.23		1.32	0.048		0.052
C3	2.20		2.60	0.087		0.102
D	8.90		9.90	0.350		0.390
E	9.90		10.3	0.390		0.406
F	6.30		6.90	0.248		0.272
G		2.54			0.1	
H	28.0		29.8	1.102		1.173
L1		3.39			0.133	
L2	1.14		1.70	0.045		0.067
L3	2.65		2.95	0.104		0.116
ϕ		3.6			0.142	

PACKAGE MECHANICAL DATA

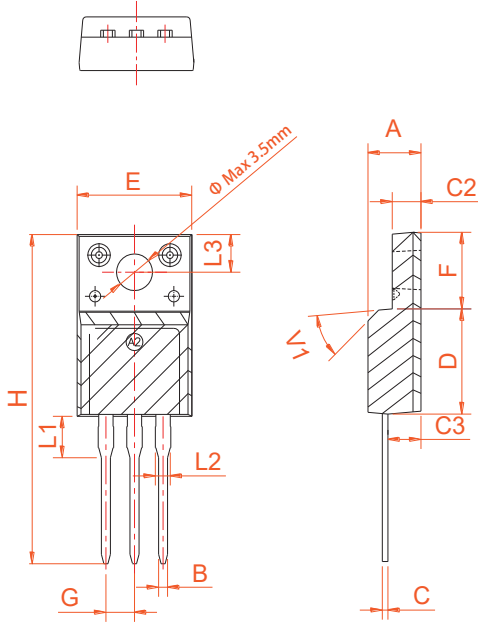

TO-220F Ins

Ref.	Dimensions					
	Millimeters			Inches		
	Min.	Typ.	Max.	Min.	Typ.	Max.
A	4.50		4.90	0.177		0.193
B	0.74	0.80	0.83	0.029	0.031	0.033
C	0.47		0.65	0.019		0.026
C2	2.45		2.75	0.096		0.108
C3	2.60		3.00	0.102		0.118
D	8.80		9.30	0.346		0.366
E	9.80		10.4	0.386		0.410
F	6.40		6.80	0.252		0.268
G		2.54			0.1	
H	28.0		29.8	1.102		1.173
L1		3.63			0.143	
L2	1.14		1.70	0.045		0.067
L3		3.30			0.130	
V1		45°			45°	

Ref.	Dimensions					
	Millimeters			Inches		
	Min.	Typ.	Max.	Min.	Typ.	Max.
A	9.90		10.20	0.390		0.402
B	14.70		15.80	0.579		0.622
C	9.4		9.6	0.37		0.378
D		2.54			0.100	
E	1.20		1.40	0.047		0.055
F	0.75		0.85	0.029		0.033
G			1.75			0.069
H	4.40		4.70	0.173		0.185
J	2.30		2.70	0.091		0.106
K	0.38		0.55	0.015		0.022
L	0	0.10	0.25	0	0.004	0.010
M	1.25		1.35	0.049		0.053

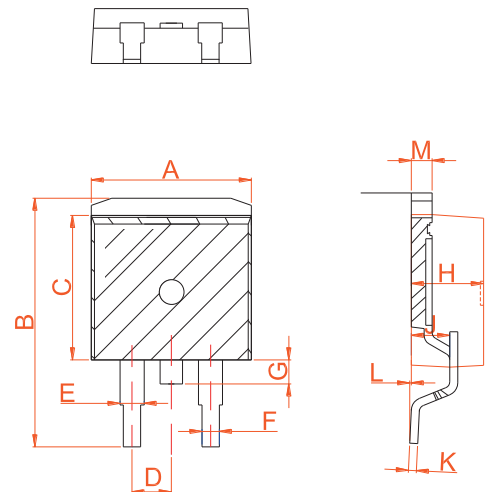

TO-263

PACKAGE MECHANICAL DATA

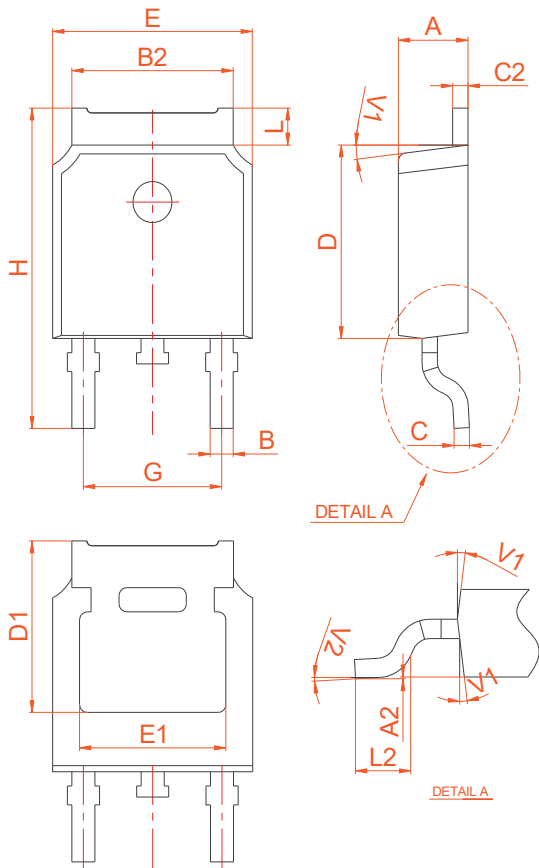

TO-252

Ref.	Dimensions					
	Millimeters			Inches		
	Min.	Typ.	Max.	Min.	Typ.	Max.
A	2.20		2.40	0.086		0.095
A2	0.03		0.23	0.001		0.009
B	0.55		0.65	0.022		0.026
B2	5.10		5.40	0.200		0.213
C	0.45		0.55	0.018		0.022
C2	2.70		2.90	0.106		0.114
D	6.00		6.20	0.236		0.244
E	6.40		6.70	0.252		0.264
G	4.40		4.70	0.173		0.185
H	9.35		10.6	0.368		0.417
L1	1.30		1.70	0.051		0.067
L2	1.37		1.50	0.054		0.059
L3		0.8			0.031	
L4		0.8			0.031	
V1		4°			4°	
V2	0°		8°	0°		8°

Information furnished is believed to be accurate and reliable. However, Shenzhen HanKingyuan Electronic assumes no responsibility for the consequences of use of such information nor for any infringement of patents or other rights of third parties which may result from its use. Specifications mentioned in this publication are subject to change without notice. This publication supersedes and replaces all information previously supplied.

The KY logo is a registered trademark of Shenzhen HanKingyuan Electronic.

©2013 Shenzhen HanKingyuan Electronic - Printed in Shenzhen - All Rights Reserved

X-ON Electronics

Largest Supplier of Electrical and Electronic Components

Click to view similar products for [Triacs](#) category:

Click to view products by [Kang Yang](#) manufacturer:

Other Similar products are found below :

[BT137-600-0Q](#) [OT415Q](#) [2N6075A](#) [NTE5688](#) [BTA2008W-800D,135](#) [D31410](#) [QJ8006NH4TP](#) [QJ8010NH5TP](#) [QJ8008NH4TP](#)
[QJ8006NH4RP](#) [QJ8010RH5TP](#) [QJ8010NH4TP](#) [QJ8006LH4TP](#) [BT136-600,127](#) [BT137B-800,118](#) [BT138-800E,127](#) [BTA140-600,127](#)
[BTA208-800B,127](#) [BTA225-800B,127](#) [MAC97A6,116](#) [BTA420-800BT,127](#) [BTA201W-800E,115](#) [BTA212B-800B,118](#) [MCR100-8](#) [100-8](#)
[MAC97A8](#) [BT137-800D](#) [BT136-800E](#) [BT137-800E](#) [BTB08-600CW](#) [BTB06-600CW](#) [BT138-800E](#) [BT152](#) [BT131-800T](#) [BT131-600D](#)
[MCR18](#) [BTA20-800B](#) [RS04K08-E](#) [AG-BK](#) [MAC4DLM-1G](#) [TMA164P-L](#) [TMA166P-L](#) [TMA54S-L](#) [BTA08-800BW3G](#) [BTA140-800,127](#)
[BTA30-600CW3G](#) [BTA30-600CW3G](#) [BTB08-800BW3G](#) [BTB16-600CW3G](#) [BTB16-600CW3G](#) [TMA84S-L](#)