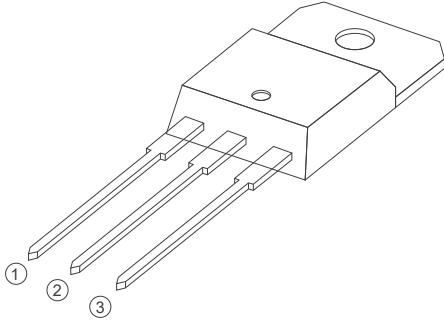
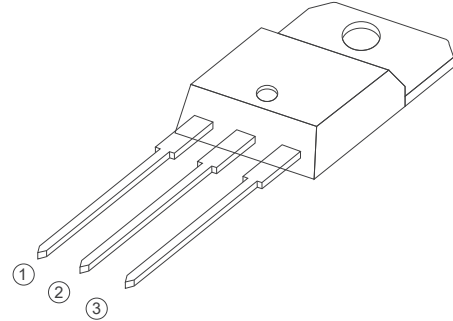


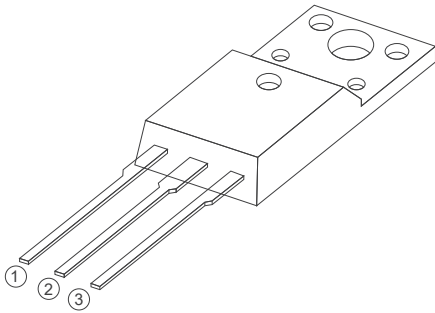
BTA/BTB24 Series  
25A TRIACs  
3 Quadrants  
4 Quadrants



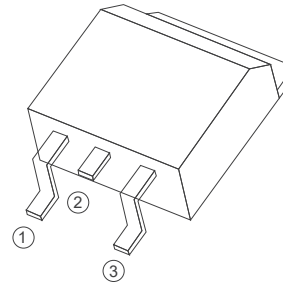
TO-220A Insulated



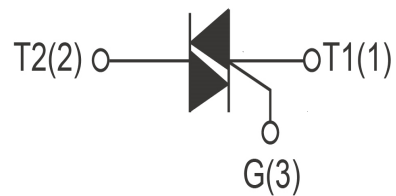
TO-220B Non-Insulated



TO-220F Insulated



TO-263



## FEATURES

>  $I_T(RMS)$ : 25A >  $V_{GT}$ : 1.5V >  $V_{DRM}$   $V_{RRM}$ : 800V and 1200V

## APPLICATIONS

Washing machine, vacuums, massager, solid state relay, AC Motor speed regulation and so on.

## Absolute Maximum Ratings (T<sub>j</sub>=25°C unless otherwise specified)

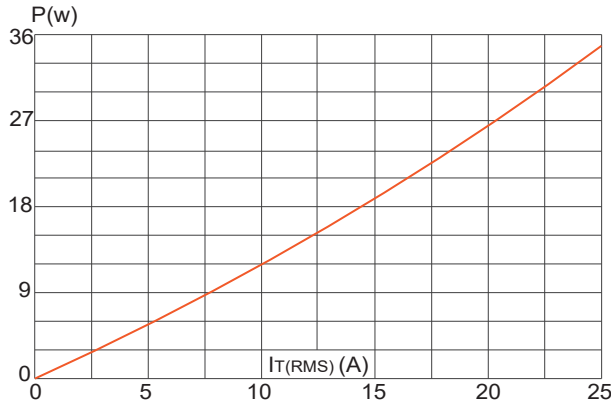
Symbol	Parameter	Conditions	Ratings	Unit
VDRM VRRM	Repetitive Peak Off-State Voltage	BTA24-800	800	V
		BTA24-1200	1200	V
IT(RMS)	R.M.S On-State Current	T <sub>c</sub> =110°C	25	A
ITSM	Surge On-State Current	t <sub>p</sub> =16.7ms/t <sub>p</sub> =10ms	280/300	A
I <sup>2</sup> t	I <sup>2</sup> t for fusing	T <sub>p</sub> =10ms	520	A <sup>2</sup> s
PG(AV)	Average Gate Power Dissipation	T <sub>j</sub> =125°C	1	W
IGM	Peak Gate Current	T <sub>j</sub> =125°C	6	A
T <sub>j</sub>	Operating Junction Temperature		~ 40~125	°C
TSTG	Storage Temperature		~ 40~150	°C

## Electrical Characteristics (T<sub>j</sub>=25°C unless otherwise specified)

Symbol	Parameter		Test Conditions	Value				Unit
				SW	CW	BW	B	
IDRM	Repetitive Peak Off-State Current		T <sub>j</sub> =25°C	5				μA
			T <sub>j</sub> =125°C	3				mA
IRRM	Repetitive Peak Reverse Current		T <sub>j</sub> =25°C	5				μA
			T <sub>j</sub> =125°C	3				mA
V <sub>TM</sub>	Forward "on" voltage		I <sub>T</sub> =35A t <sub>p</sub> =380us	1.55				V
V <sub>GT</sub>	Gate trigger voltage		V <sub>D</sub> =12V ,R <sub>L</sub> =30Ω	≤1.5				V
di/dt	Critical rate of rise of on-state current	I,II,III	F=120Hz,T <sub>j</sub> =125°C I <sub>G</sub> =2xI <sub>GT</sub> ,tr≤100ns	≥50				A/us
		IV		≥10				A/us
I <sub>GT</sub>	Gate trigger current	I,II,III	V <sub>D</sub> =12V R <sub>L</sub> =30Ω	≤10	≤35	≤50	≤50	mA
		IV			/	/	≤100	mA
I <sub>H</sub>	Holding current		I <sub>T</sub> =0.2A	≤40	≤60	≤80	≤80	mA
V <sub>DG</sub>	Gate non-trigger voltage	ALL	V <sub>D</sub> =V <sub>DRM</sub> T <sub>J</sub> =125°C	≥0.2				V
dv/dt	Critical-rate of rise of commutation voltage		T <sub>J</sub> =125°C V <sub>D</sub> =2/3V <sub>DRM</sub> Gate open circuit	≥200	≥400	≥1000	≥500	V/us

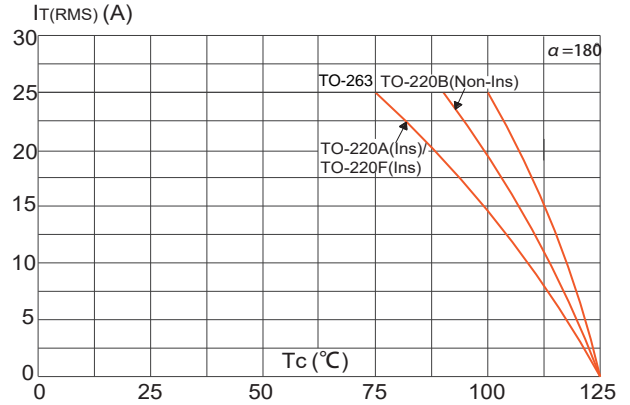
**FIG1**

Maximum power dissipation versus RMS on-state current



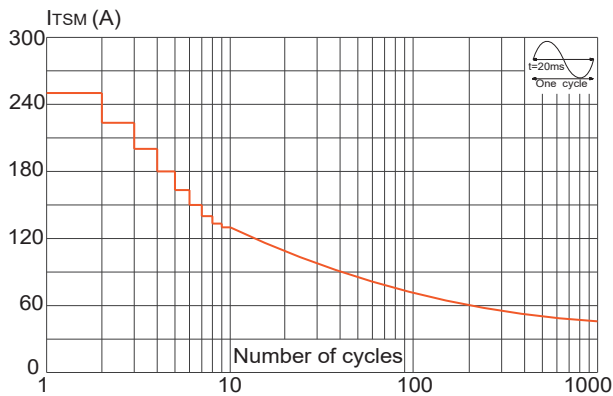
**FIG2**

RMS on-state current versus case temperature



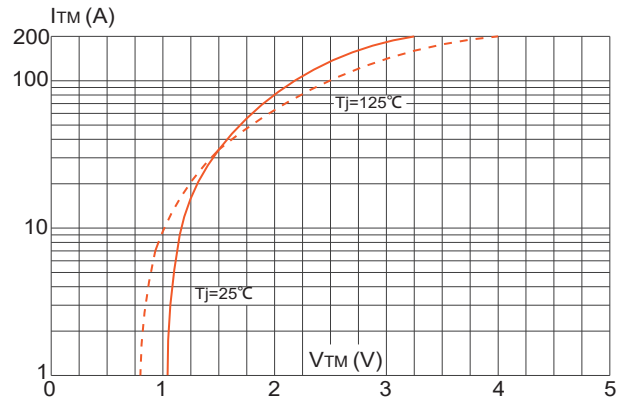
**FIG3**

Surge peak on-state current versus number of cycles



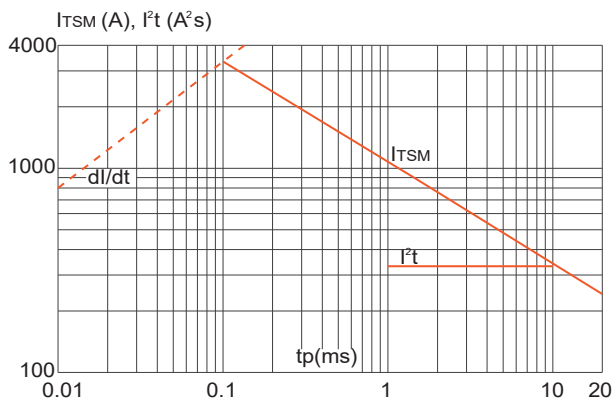
**FIG4**

On-state characteristics (maximum values)



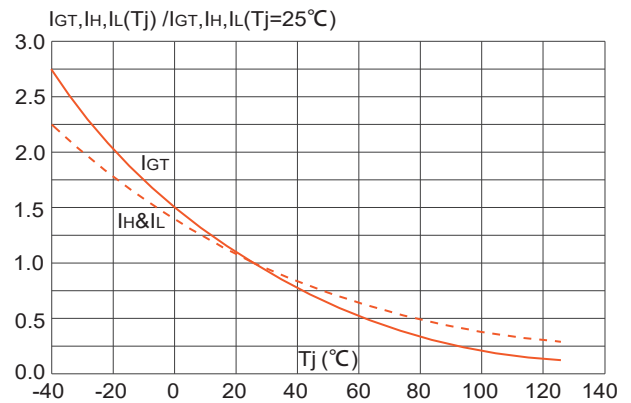
**FIG5**

Non-repetitive surge peak on-state current for a sinusoidal pulse with width  $t_p < 20ms$ , and

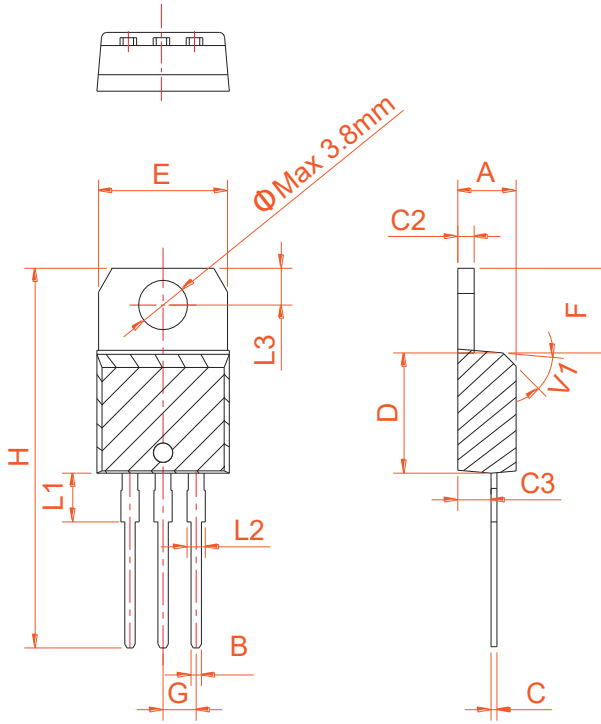


**FIG6**

Relative variations of gate trigger current, holding current and latching current versus junction temperature



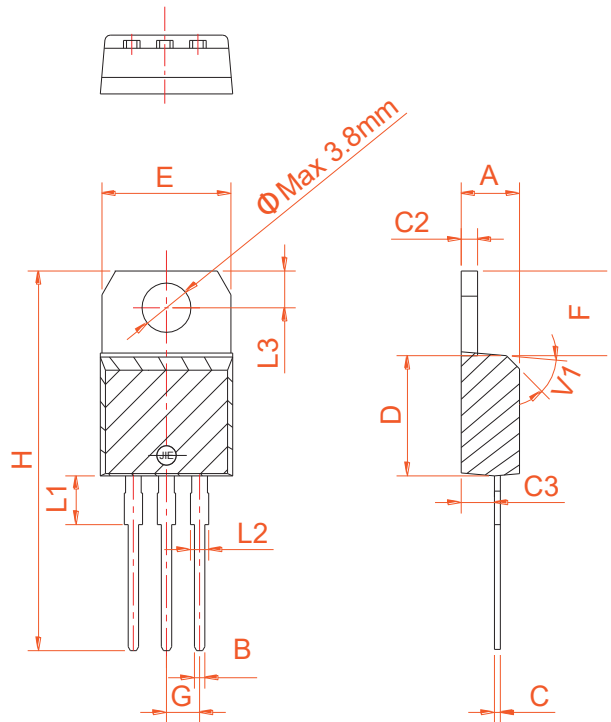
**PACKAGE MECHANICAL DATA**



TO-220A Ins

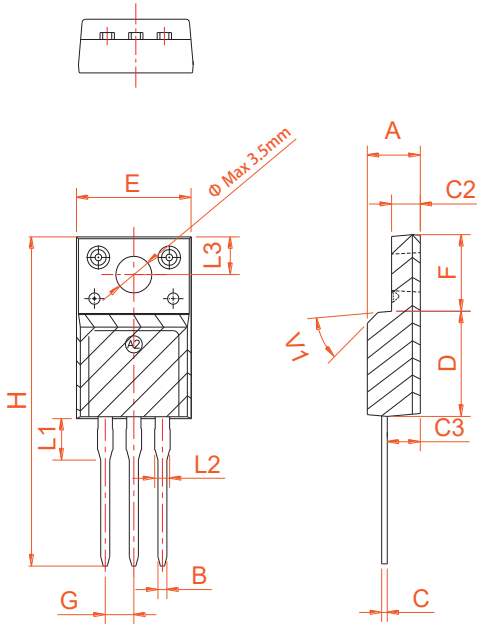
Ref.	Dimensions					
	Millimeters			Inches		
	Min.	Typ.	Max.	Min.	Typ.	Max.
A	4.40		4.60	0.173		0.181
B	0.61		0.88	0.024		0.035
C	0.46		0.70	0.018		0.028
C2	1.21		1.32	0.048		0.052
C3	2.40		2.72	0.094		0.107
D	8.60		9.70	0.339		0.382
E	9.80		10.4	0.386		0.409
F	6.55		6.95	0.258		0.274
G		2.54			0.1	
H	28.0		29.8	1.102		1.173
L1		3.75			0.148	
L2	1.14		1.70	0.045		0.067
L3	2.65		2.95	0.104		0.116
V1		45°			45°	

Ref.	Dimensions					
	Millimeters			Inches		
	Min.	Typ.	Max.	Min.	Typ.	Max.
A	4.40		4.60	0.173		0.181
B	0.61		0.88	0.024		0.035
C	0.46		0.70	0.018		0.028
C2	1.21		1.32	0.048		0.052
C3	2.40		2.72	0.094		0.107
D	8.60		9.70	0.339		0.382
E	9.60		10.4	0.378		0.409
F	6.20		6.60	0.244		0.260
G		2.54			0.1	
H	28.0		29.8	1.102		1.173
L1		3.75			0.148	
L2	1.14		1.70	0.045		0.067
L3	2.65		2.95	0.104		0.116
V1		45°			45°	



TO-220B Non-Ins

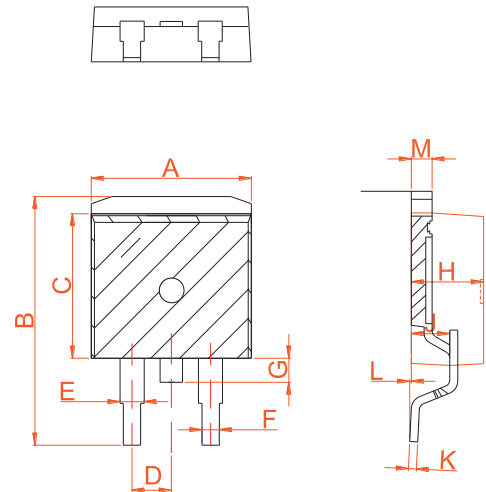
**PACKAGE MECHANICAL DATA**



TO-220F Ins

Ref.	Dimensions					
	Millimeters			Inches		
	Min.	Typ.	Max.	Min.	Typ.	Max.
A	4.50		4.90	0.177		0.193
B	0.74	0.80	0.83	0.029	0.031	0.033
C	0.47		0.65	0.019		0.026
C2	2.45		2.75	0.096		0.108
C3	2.60		3.00	0.102		0.118
D	8.80		9.30	0.346		0.366
E	9.80		10.4	0.386		0.410
F	6.40		6.80	0.252		0.268
G		2.54			0.1	
H	28.0		29.8	1.102		1.173
L1		3.63			0.143	
L2	1.14		1.70	0.045		0.067
L3		3.30			0.130	
V1		45°			45°	

Ref.	Dimensions					
	Millimeters			Inches		
	Min.	Typ.	Max.	Min.	Typ.	Max.
A	9.90		10.20	0.390		0.402
B	14.70		15.80	0.579		0.622
C	9.4		9.6	0.37		0.378
D		2.54			0.100	
E	1.20		1.40	0.047		0.055
F	0.75		0.85	0.029		0.033
G			1.75			0.069
H	4.40		4.70	0.173		0.185
J	2.30		2.70	0.091		0.106
K	0.38		0.55	0.015		0.022
L	0	0.10	0.25	0	0.004	0.010
M	1.25		1.35	0.049		0.053



TO-263



Information furnished is believed to be accurate and reliable. However, Shenzhen HanKingyuan Electronic assumes no responsibility for the consequences of use of such information nor for any infringement of patents or other rights of third parties which may result from its use. Specifications mentioned in this publication are subject to change without notice. This publication supersedes and replaces all information previously supplied.

The KY logo is a registered trademark of Shenzhen HanKingyuan Electronic.

©2013 Shenzhen HanKingyuan Electronic - Printed in Shenzhen - All Rights Reserved

## X-ON Electronics

Largest Supplier of Electrical and Electronic Components

*Click to view similar products for [Triacs](#) category:*

*Click to view products by [Kang Yang](#) manufacturer:*

Other Similar products are found below :

[BT137-600-0Q](#) [OT415Q](#) [2N6075A](#) [NTE5688](#) [BTA2008W-800D,135](#) [D31410](#) [ACS102-5T1](#) [ACS102-5TA](#) [MAC97A4G](#) [Z0107MAG](#)  
[Z0107MARL1G](#) [Z0109MARLRPG](#) [MAC97A8-TA](#) [BT131W-800](#) [BT138S-800E](#) [BT137S-800E](#) [BT136S-600D](#) [BTA08-600TWRG](#)  
[X0405MF-252](#) [MAC97A8-23-3L](#) [MCR100-8-23-3L](#) [BTA24-800B](#) [BT151-600R](#) [BT131](#) [BTA41-1200B](#) [MCR16](#) [MCR100-8](#) [MCR16](#)  
[BT131-800D](#) [BT134-800E](#) [BT138-800E](#) [MCR100-8](#) [BTA12-800BWRG\(UMW\)](#) [BTA24-600BWRG\(UMW\)](#) [BTA24-800BWRG\(UMW\)](#)  
[BTA12-600BWRG\(UMW\)](#) [BTA16-600CRG\(UMW\)](#) [BTA12-600CRG\(UMW\)](#) [BS61089B-8](#) [BT134W-600E](#) [BT134-600E](#) [JR0405S3](#)  
[BCR12PM](#) [MAC97A6](#) [MAC4DLM-1G](#) [BT137-600E,127](#) [BTA08-800BW3G](#) [BTA140-800,127](#) [BTA30-600CW3G](#) [BTA30-600CW3G](#)