

TYN612 Series
12A SCRs
Standard SCRs

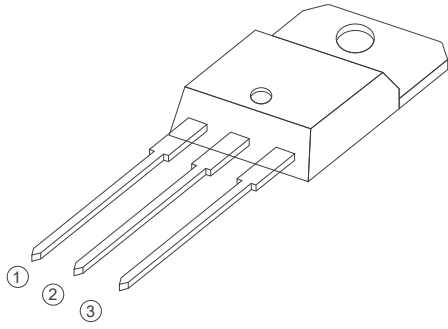

TO-220B Non-Insulated

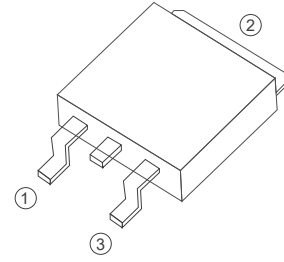

TO-252

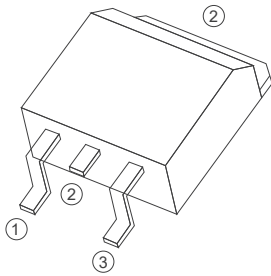

TO-263

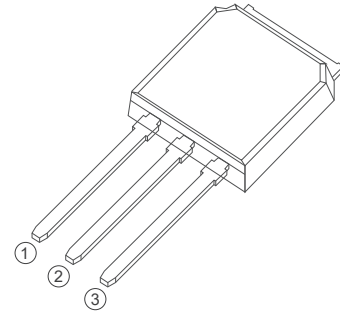

TO-251

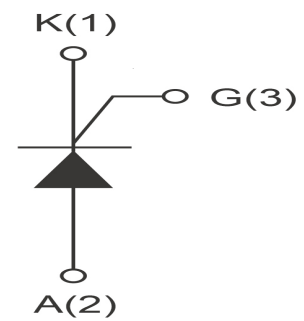

FEATURES

> $I_T(RMS)$:12A > V_{GT} : 1.5V > V_{DRM} V_{RRM} :600Vand800V

APPLICATIONS

Washing machine,vacuums, massager,solid state relay, AC Motor speed regulation and so on.

Absolute Maximum Ratings (T_J=25°C unless otherwise specified)

Symbol	Parameter	Conditions	Ratings	Unit
VDRM VRRM	Repetitive Peak Off-State Voltage	TYN612 /TYN812	600/800	V
IT(RMS)	R.M.S On-State Current	T _c =105°C	12	A
IT(AV)	On-state average current	T _C =105°C	7.5	A
ITSM	Surge On-State Current	T _p =10ms/t _p =8.3ms	120/132	A
I ² t	I ² t for fusing	T _p =10ms	75	A ² s
PGM	Peak Gate Power Dissipation	T _J =125°C	2	W
PG(AV)	Average Gate Power Dissipation	T _J =125°C	0.5	W
T _J	Operating Junction Temperature		~40~125	°C
TSTG	Storage Temperature		~40~150	°C

Electrical Characteristics (T_J=25°C unless otherwise specified)

Symbol	Parameter	Test Conditions	Value	Unit
IDRM	Repetitive Peak Off-State Current	T _c =25°C	≤10	uA
		T _c =125°C	≤1	mA
IRRM	Repetitive Peak Reverse Current	T _c =25°C	≤10	uA
		T _c =125°C	≤1	mA
VTM	Forward "on" voltage	I _T =23A t _p =380us	≤1.7	V
VGT	Gate trigger voltage	V _D =12V ,I _T =0.1A	≤1.0	V
di/dt	Critical rate of rise of on-state current	T _J =125°C, I _G =2xI _{GT} , t _r ≤100ns	≥50	A/us
IGT	Gate trigger current	V _D =12V I _T =0.1A	≤20	mA
IL	Latching current	I _G =1.2I _{GT}	≤40	mA
IH	Holding current	I _T =0.1A	≤30	mA
VGD	Gate non-trigger voltage	V _D =VDRM T _J =125°C, R _L =3.3KΩ, R _{GK} =1KΩ	≥0.25	V
dv/dt	Critical-rate of rise of commutation voltage	T _J =125°C V _D =2/3VDRM Gate open circuit	≥200	V/us
R _{th(j-c)}	Thermal resistance	Junction to case	1	°C/W
R _{th(j-a)}	Thermal resistance	Junction to ambient	50	°C/W

FIG1

Maximum power dissipation versus RMS on-state current

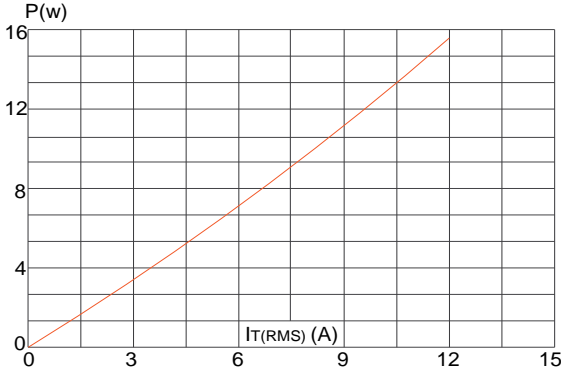

FIG2

RMS on-state current versus case temperature

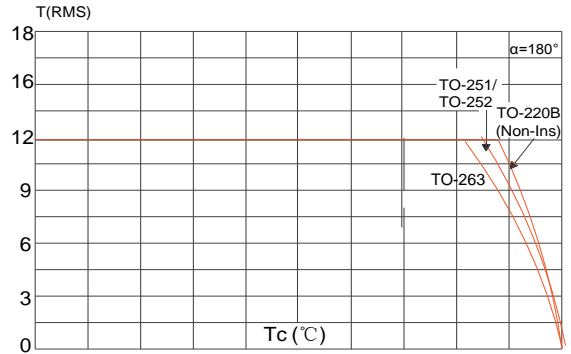

FIG3

Surge peak on-state current versus number of cycles

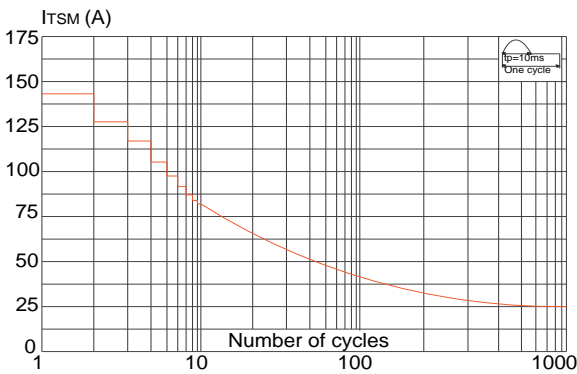

FIG4

On-state characteristics (maximum values)

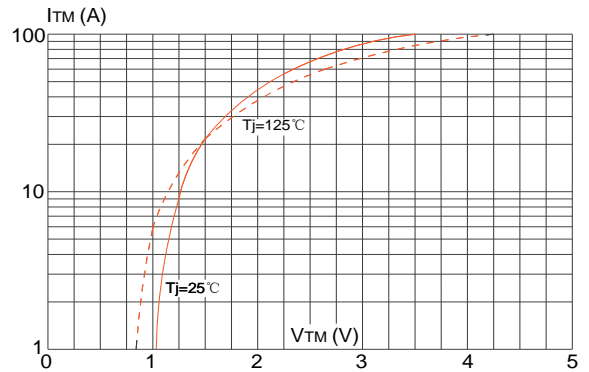

FIG5

Non-repetitive surge peak on-state current for a sinusoidal pulse with width $t_p < 20ms$, and corresponding value of I^2t ($di/dt < 100A/\mu s$)

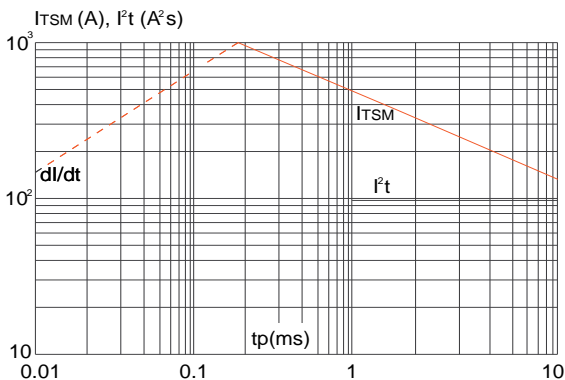
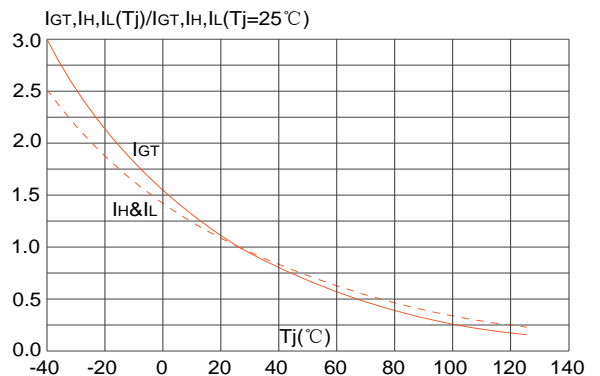
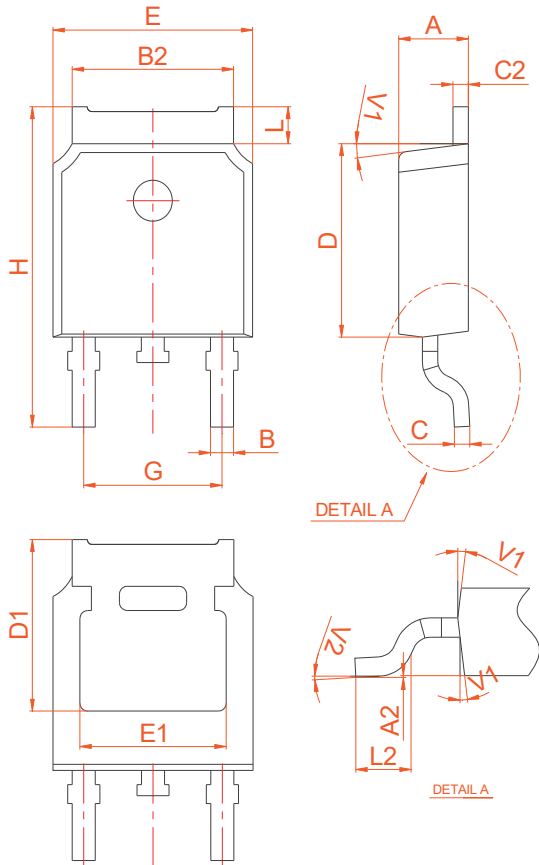

FIG6

Relative variations of gate trigger current, holding current and latching current versus junction temperature



PACKAGE MECHANICAL DATA



TO-252

Ref.	Dimensions					
	Millimeters			Inches		
	Min.	Typ.	Max.	Min.	Typ.	Max.
A	2.20		2.40	0.086		0.095
A2	0.03		0.23	0.001		0.009
B	0.55		0.65	0.022		0.026
B2	5.10		5.40	0.200		0.213
C	0.45		0.55	0.018		0.022
C2	2.70		2.90	0.106		0.114
D	6.00		6.20	0.236		0.244
E	6.40		6.70	0.252		0.264
G	4.40		4.70	0.173		0.185
H	9.35		10.6	0.368		0.417
L1	1.30		1.70	0.051		0.067
L2	1.37		1.50	0.054		0.059
L3		0.8			0.031	
L4		0.8			0.031	
V1		4°			4°	
V2	0°		8°	0°		8°

Ref.	Dimensions					
	Millimeters			Inches		
	Min.	Typ.	Max.	Min.	Typ.	Max.
A	4.40		4.60	0.173		0.181
B	0.61		0.88	0.024		0.035
C	0.46		0.70	0.018		0.028
C2	1.21		1.32	0.048		0.052
C3	2.40		2.72	0.094		0.107
D	8.60		9.70	0.339		0.382
E	9.60		10.4	0.378		0.409
F	6.20		6.60	0.244		0.260
G		2.54			0.1	
H	28.0		29.8	1.102		1.173
L1		3.75			0.148	
L2	1.14		1.70	0.045		0.067
L3	2.65		2.95	0.104		0.116
V1		45°			45°	

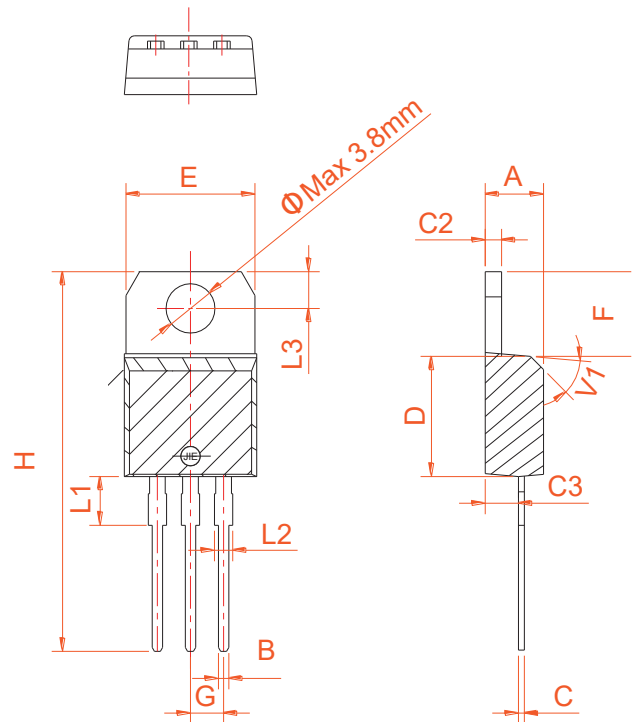

TO-220B Non-Ins

PACKAGE MECHANICAL DATA

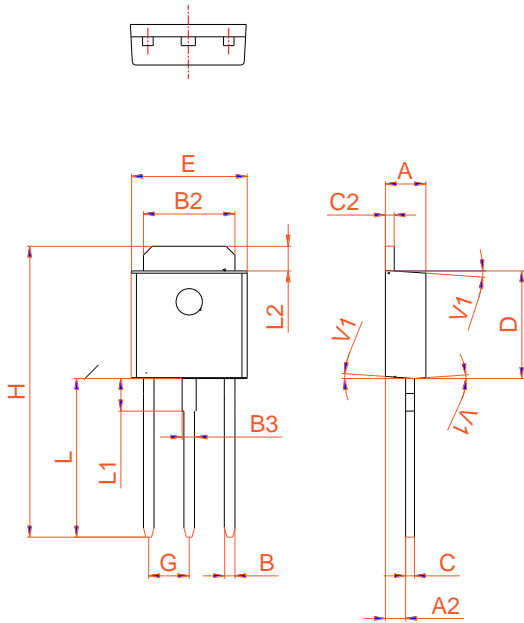

TO-251

Ref.	Dimensions					
	Millimeters			Inches		
	Min.	Typ.	Max.	Min.	Typ.	Max.
A	2.20		2.40	0.086		0.095
A2	0.90		1.20	0.035		0.047
B	0.55		0.65	0.022		0.026
B2	5.10		5.40	0.200		0.213
B3	0.76		0.85	0.030		0.033
C	0.45		0.62	0.018		0.024
C2	0.48		0.62	0.019		0.024
D	6.00		6.20	0.236		0.244
E	6.40		6.70	0.252		0.264
G		2.30			0.091	
H	16.0		17.0	0.630		0.669
L	8.90		9.40	0.350		0.370
L1	1.80		1.90	0.071		0.075
L2	1.37		1.50	0.054		0.059
V1		4°			4°	

Ref.	Dimensions					
	Millimeters			Inches		
	Min.	Typ.	Max.	Min.	Typ.	Max.
A	9.90		10.20	0.390		0.402
B	14.70		15.80	0.579		0.622
C	9.4		9.6	0.37		0.378
D		2.54			0.100	
E	1.20		1.40	0.047		0.055
F	0.75		0.85	0.029		0.033
G			1.75			0.069
H	4.40		4.70	0.173		0.185
J	2.30		2.70	0.091		0.106
K	0.38		0.55	0.015		0.022
L	0	0.10	0.25	0	0.004	0.010
M	1.25		1.35	0.049		0.053

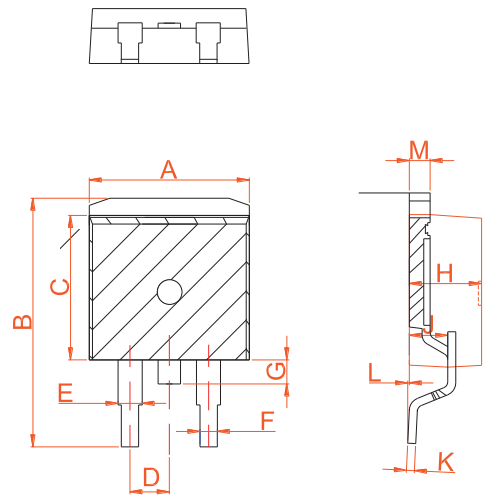

TO-263



Information furnished is believed to be accurate and reliable. However, Shenzhen HanKingyuan Electronic assumes no responsibility for the consequences of use of such information nor for any infringement of patents or other rights of third parties which may result from its use. Specifications mentioned in this publication are subject to change without notice. This publication supersedes and replaces all information previously supplied.

The KY logo is a registered trademark of Shenzhen HanKingyuan Electronic.

©2013 Shenzhen HanKingyuan Electronic - Printed in Shenzhen - All Rights Reserved

X-ON Electronics

Largest Supplier of Electrical and Electronic Components

Click to view similar products for [Triacs](#) category:

Click to view products by [Kang Yang](#) manufacturer:

Other Similar products are found below :

[BT137-600-0Q](#) [OT415Q](#) [2N6075A](#) [NTE5688](#) [BTA2008W-800D,135](#) [D31410](#) [QJ8006NH4TP](#) [QJ8010NH5TP](#) [QJ8008NH4TP](#)
[QJ8006NH4RP](#) [QJ8010RH5TP](#) [QJ8010NH4TP](#) [QJ8006LH4TP](#) [BT136-600,127](#) [BT137B-800,118](#) [BT138-800E,127](#) [BTA140-600,127](#)
[BTA208-800B,127](#) [BTA225-800B,127](#) [MAC97A6,116](#) [BTA420-800BT,127](#) [BTA201W-800E,115](#) [BTA212B-800B,118](#) [MCR100-8](#) [100-8](#)
[BT131S](#) [MCR100-6](#) [MCR100-8](#) [BT136S-800E](#) [BT134S-600E](#) [BT151-650R](#) [BT136-800E](#) [BTA12-800B](#) [BT138S-800E](#) [MAC97A8](#)
[BT137S-800E](#) [BT169-23](#) [BT131-89-2L](#) [MAC97A6-23-3L](#) [BT169-89-2L](#) [BT139-800E](#) [MCR100-8](#) [BT169-MS](#) [MCR100-8](#) [MCR100-6](#)
[BTA408X-1000C0T,127](#) [ACT108-800EQP](#) [BTA201-800ER,116](#) [T810](#) [2P4M](#) [BT137-600E](#)