

TYN625 Series
25A SCRs
Standard SCRs

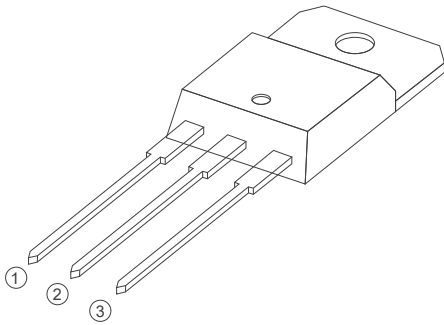

TO-220A Insulated

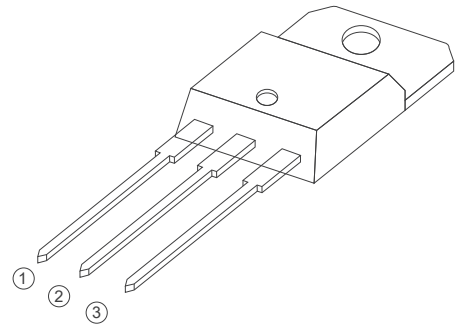

TO-220B Non-Insulated

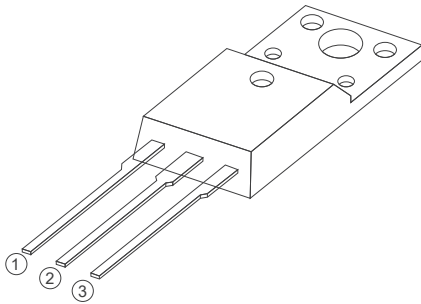

TO-220F Insulated

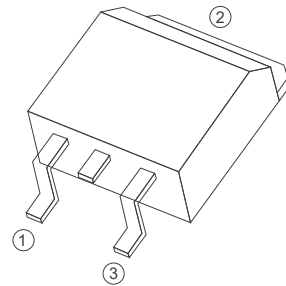

TO-263

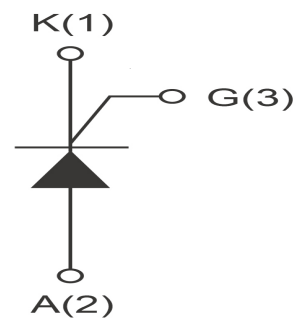

FEATURES

> IT(RMS):25A > VGT: 1.5V > VDRM VRRM:600Vand800V

APPLICATIONS

Washing machine,vacuums, massager,solid state relay, AC Motor speed regulation and so on.

Absolute Maximum Ratings (T_j=25°C unless otherwise specified)

Symbol	Parameter	Conditions	Ratings	Unit
VDRM VRRM	Repetitive Peak Off-State Voltage	TYN625	600	V
		TYN825	800	
IT(RMS)	R.M.S On-State Current		25	A
ITSM	Surge On-State Current	F=50Hz, tp=10ms	300	A
I ² t	I ² t for fusing	tp=10ms	450	A ² s
IGM	Peak Gate Current	tp=20us T _j =110°C	4	A
PG(AV)	Average Gate Power Dissipation	T _j =125°C	1	W
PGM	Peak Gate Current	T _j =125°C	5	W
T _j	Operating Junction Temperature		~40~125	°C
TSTG	Storage Temperature		~40~150	°C

Electrical Characteristics (T_j=25°C unless otherwise specified)

Symbol	Parameter	Test Conditions	Value	Unit
IDRM	Repetitive Peak Off-State Current	T _c =25°C	≤10	uA
		T _c =125°C	≤4	mA
IRRM	Repetitive Peak Reverse Current	T _c =25°C	≤10	uA
		T _c =125°C	≤4	mA
VTM	Forward "on" voltage	I _T =50A tp=380us	≤1.55	V
VGD	Gate nontrigger voltage	V _D =VDRM, T _j =125°C, R _L =3.3KΩ	≥0.25	V
IL	Latching current	I _G =1.2I _{GT}	≤90	mA
I _H	Holding current	V _D =12V, I _{GT} =0.1A	≤80	mA
VGT	Gate trigger voltage	V _D =12V	≤1.3	V
I _{GT}	Gate trigger current	V _D =12V, I _T =0.1A	≤40	mA
dv/dt	Critical-rate of rise of commutation voltage	V _D =2/3VDRM, T _j =110°C, R _{GK} =1KΩ	≥200	V/us
di/dt	Critical-rate of rise of commutation current	I _G =2X I _{GT} , tr≤100us, T _j =125°C	≥50	A/us

FIG1

Maximum power dissipation versus RMS on-state current

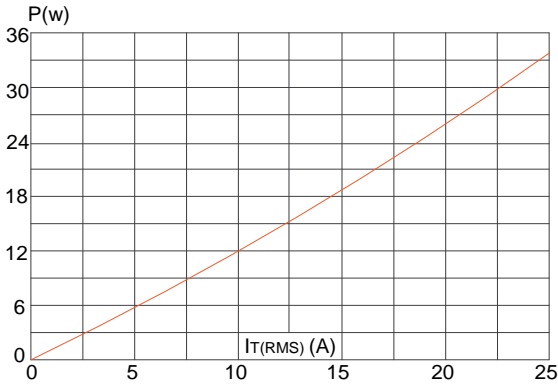

FIG2

RMS on-state current versus case temperature

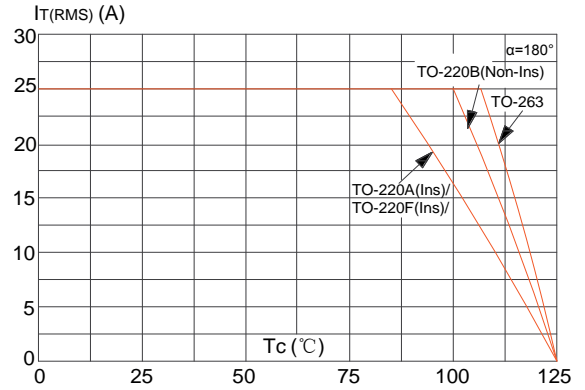

FIG3

Surge peak on-state current versus number of cycles

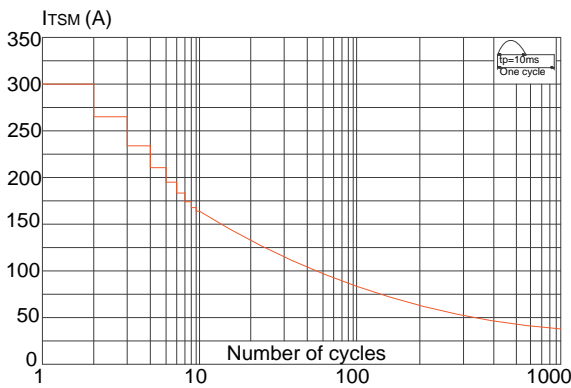

FIG4

On-state characteristics (maximum values)

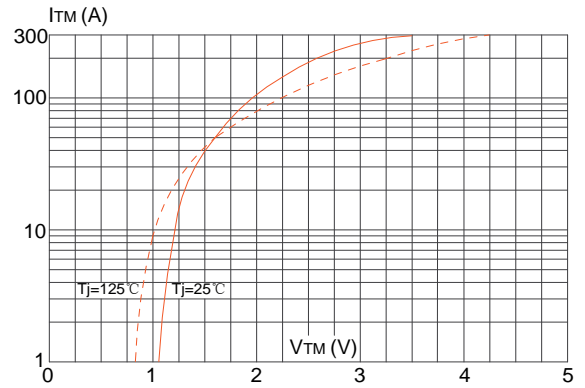

FIG5

Non-repetitive surge peak on-state current for a sinusoidal pulse with width $t_p < 20\text{ms}$, and corresponding value of I^2t ($di/dt < 100\text{A}/\mu\text{s}$)

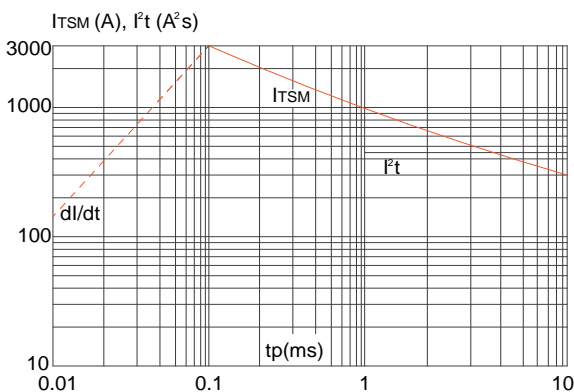
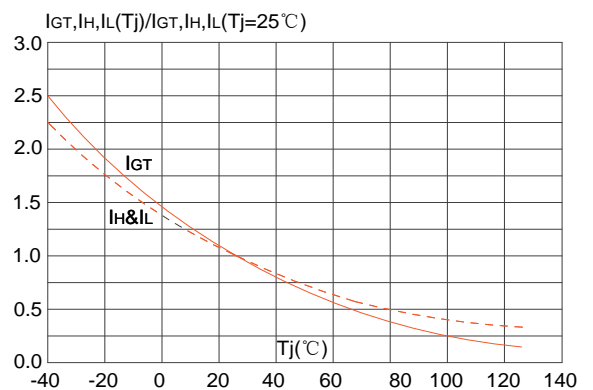
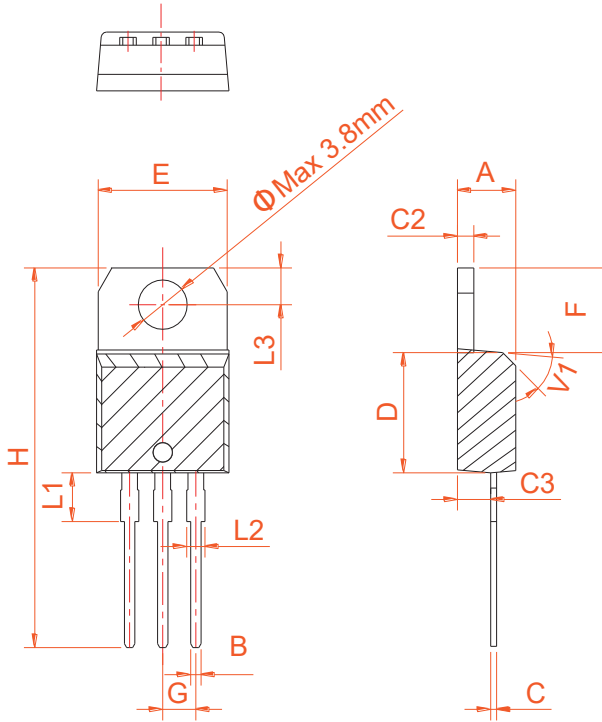

FIG6

Relative variations of gate trigger current, holding current and latching current versus junction temperature



PACKAGE MECHANICAL DATA



Ref.	Dimensions					
	Millimeters			Inches		
	Min.	Typ.	Max.	Min.	Typ.	Max.
A	4.40		4.60	0.173		0.181
B	0.61		0.88	0.024		0.035
C	0.46		0.70	0.018		0.028
C2	1.21		1.32	0.048		0.052
C3	2.40		2.72	0.094		0.107
D	8.60		9.70	0.339		0.382
E	9.80		10.4	0.386		0.409
F	6.55		6.95	0.258		0.274
G		2.54			0.1	
H	28.0		29.8	1.102		1.173
L1		3.75			0.148	
L2	1.14		1.70	0.045		0.067
L3	2.65		2.95	0.104		0.116
V1		45°			45°	

TO-220A Ins

Ref.	Dimensions					
	Millimeters			Inches		
	Min.	Typ.	Max.	Min.	Typ.	Max.
A	4.40		4.60	0.173		0.181
B	0.61		0.88	0.024		0.035
C	0.46		0.70	0.018		0.028
C2	1.21		1.32	0.048		0.052
C3	2.40		2.72	0.094		0.107
D	8.60		9.70	0.339		0.382
E	9.60		10.4	0.378		0.409
F	6.20		6.60	0.244		0.260
G		2.54			0.1	
H	28.0		29.8	1.102		1.173
L1		3.75			0.148	
L2	1.14		1.70	0.045		0.067
L3	2.65		2.95	0.104		0.116
V1		45°			45°	

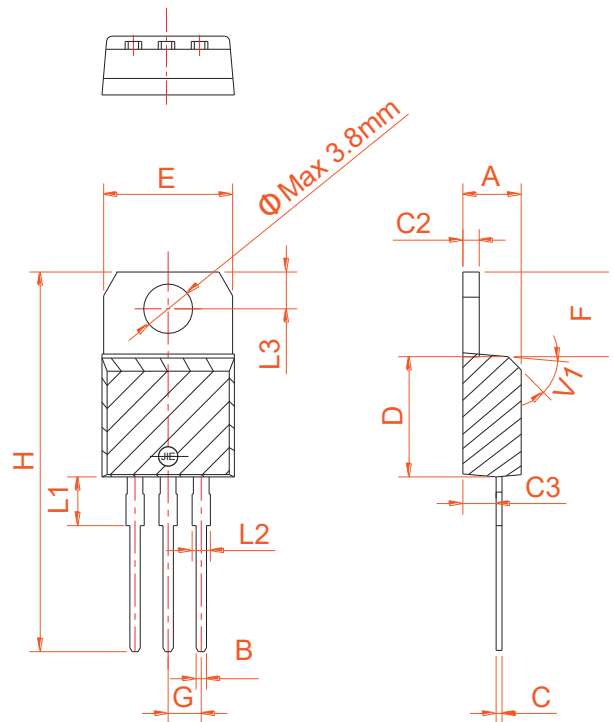

TO-220B Non-Ins

PACKAGE MECHANICAL DATA

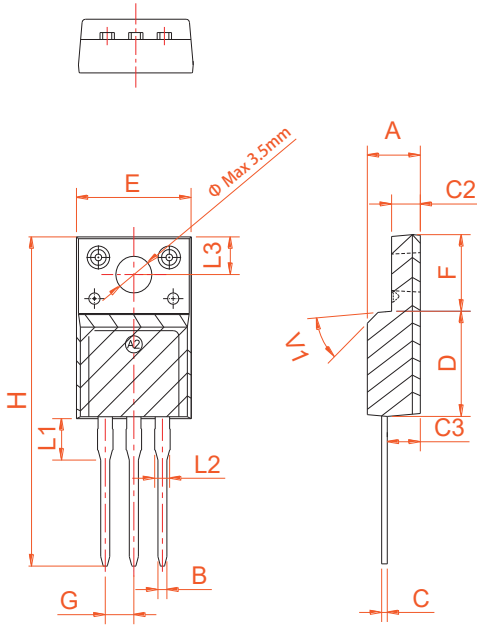

TO-220F Ins

Ref.	Dimensions					
	Millimeters			Inches		
	Min.	Typ.	Max.	Min.	Typ.	Max.
A	4.50		4.90	0.177		0.193
B	0.74	0.80	0.83	0.029	0.031	0.033
C	0.47		0.65	0.019		0.026
C2	2.45		2.75	0.096		0.108
C3	2.60		3.00	0.102		0.118
D	8.80		9.30	0.346		0.366
E	9.80		10.4	0.386		0.410
F	6.40		6.80	0.252		0.268
G		2.54			0.1	
H	28.0		29.8	1.102		1.173
L1		3.63			0.143	
L2	1.14		1.70	0.045		0.067
L3		3.30			0.130	
V1		45°			45°	

Ref.	Dimensions					
	Millimeters			Inches		
	Min.	Typ.	Max.	Min.	Typ.	Max.
A	9.90		10.20	0.390		0.402
B	14.70		15.80	0.579		0.622
C	9.4		9.6	0.37		0.378
D		2.54			0.100	
E	1.20		1.40	0.047		0.055
F	0.75		0.85	0.029		0.033
G			1.75			0.069
H	4.40		4.70	0.173		0.185
J	2.30		2.70	0.091		0.106
K	0.38		0.55	0.015		0.022
L	0	0.10	0.25	0	0.004	0.010
M	1.25		1.35	0.049		0.053

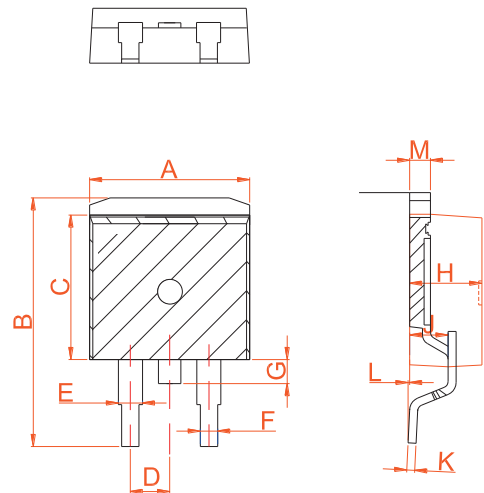

TO-263



Information furnished is believed to be accurate and reliable. However, Shenzhen HanKingyuan Electronic assumes no responsibility for the consequences of use of such information nor for any infringement of patents or other rights of third parties which may result from its use. Specifications mentioned in this publication are subject to change without notice. This publication supersedes and replaces all information previously supplied.

The KY logo is a registered trademark of Shenzhen HanKingyuan Electronic.

©2013 Shenzhen HanKingyuan Electronic - Printed in Shenzhen - All Rights Reserved

X-ON Electronics

Largest Supplier of Electrical and Electronic Components

Click to view similar products for [Triacs](#) category:

Click to view products by [Kang Yang](#) manufacturer:

Other Similar products are found below :

[BT137-600-0Q](#) [OT415Q](#) [2N6075A](#) [NTE5688](#) [BTA2008W-800D,135](#) [D31410](#) [ACS102-5T1](#) [ACS102-5TA](#) [MAC97A4G](#) [Z0107MAG](#)
[Z0107MARL1G](#) [Z0109MARLRPG](#) [MAC97A8-TA](#) [BT131W-800](#) [BT138S-800E](#) [BT137S-800E](#) [BT136S-600D](#) [BTA08-600TWRG](#)
[X0405MF-252](#) [MAC97A8-23-3L](#) [MCR100-8-23-3L](#) [BTA24-800B](#) [BT151-600R](#) [BT131](#) [BTA41-1200B](#) [MCR16](#) [MCR100-8](#) [MCR16](#)
[BT131-800D](#) [BT134-800E](#) [BT138-800E](#) [MCR100-8](#) [BTA12-800BWRG\(UMW\)](#) [BTA24-600BWRG\(UMW\)](#) [BTA24-800BWRG\(UMW\)](#)
[BTA12-600BWRG\(UMW\)](#) [BTA16-600CRG\(UMW\)](#) [BTA12-600CRG\(UMW\)](#) [BS61089B-8](#) [BT134W-600E](#) [BT134-600E](#) [JR0405S3](#)
[BCR12PM](#) [MAC97A6](#) [BTA24-800CRG\(UMW\)](#) [BTA16-600BRG\(UMW\)](#) [BTA16-800BWRG\(UMW\)](#) [Z0109-NN](#) [BTA41](#) [MCR100-8U](#)