



Serial No. : 2014-0416

DATE : 2014/04/04

ITEM : **CRYSTAL RESONATOR**

DSX321G 12.000MHz

(INDONESIA) 1C212000BCOAK

(THAILAND) 1N212000BCOAK

Please acknowledge receipt of this specification by signing and returning a copy to us.

RECEIPT	
DATE	
RECEIVED	(signature) (name)

General Manufacturer of Quartz Devices

DAISHINKU CORP.

1389 Shinzaike, Hiraoka-cho, Kakogawa, Hyogo
675-0194 Japan

Phone (81)79-425-3141 Fax (81)79-425-1134

http://www.kds.info/index_en.htm

C.ENG.

T. Okishio

ENG.

S. Miura

1. ELECTRICAL CHARACTERISTICS

(This test shall be performed under the conditions of temp.at +25 ± 3°C, Relative Humidity 60% max.)

(1) NOMINAL FREQUENCY	12.000000 MHz
(2) OVERTONE ORDER	Fundamental
(3) LOAD CAPACITANCE(CL)	12.0 pF
(4) FREQUENCY TOLERANCE	±20 ppm max. (at +25 ± 3 °C)
(5) DRIVE LEVEL	175 ± 10 μW
(6) SERIES RESISTANCE	80 Ω max. (at Series)
(7) OPERATING TEMPERATURE RANGE	-10 ~ +70 °C
(8) FREQUENCY CHARACTERISTICS OVER TEMPERATURE	±30 ppm max. / -10 ~ +70 °C (ref. to +25°C)
(9) SHUNT CAPACITANCE	2.0pF max.
(10) INSULATION RESISTANCE	500MΩ min. / DC 100 ± 15V
(11) STORAGE TEMPERATURE RANGE	-40 ~ +85 °C

2. CONSTRUCTION

(1) DIMENSIONS AND MARKING Refer to 4.

3. OTHER SPECIFICATIONS

- (1) EMBOSS CARRIER TAPE & REEL Refer to 5.
- (2) PACKING Refer to 6.
- (3) REFLOW CONDITIONS (REFERENCE) Refer to 7.
- (4) LAND PATTERN (REFERENCE) Refer to 8.
- (5) RELIABILITY SPECIFICATION Refer to 9. ~ 11.
- (6) OTHER HANDLING INSTRUCTIONS Refer to 12.

TITLE DSX321G TYPE QUARTZ CRYSTAL SPECIFICATION	REMARK		
DATE 2014/04/04	SPEC. No. 1C212000BC0AK 1N212000BC0AK	REV.	PAGE 1 / 12

4. DIMENSIONS AND MARKING

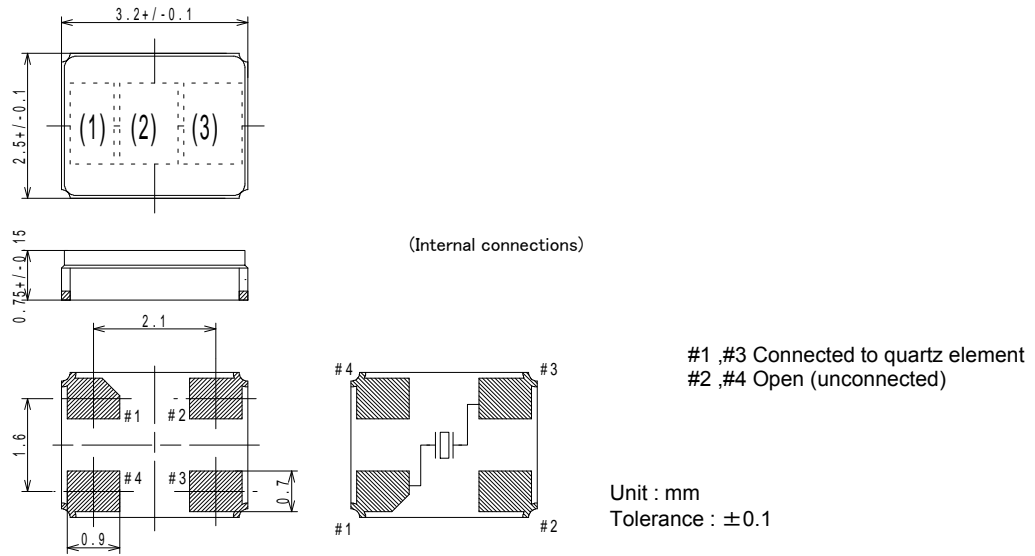

Figure-1

Logo(1) and Nominal Frequency (2) should be printed as follows by producing district

Made in INDONESIA --> Spec. No.: 1C212000BC0AK , Logo : D , Frequency: 12

Made in THAILAND --> Spec. No.: 1N212000BC0AK , Logo : , Frequency: 12

* Made in INDONESIA : Under Bar with D
 * Made in THAILAND : Top Bar with D

Nominal Frequency (2) = Mark two digits from upper decimal point
 (ex. 12.000000 MHz ----> 12)

Manufacturing lot No.(3)

(year) ex. 2014 shall be marked as ' 4 ' (The last digit of the year)
 (Month) ex. Apr. shall be marked as ' D ' (As shown in Table-1.)

(Table-1.)

Month	Jan.	Feb.	Mar.	Apr.	May.	Jun.	Jul.	Aug.	Sep.	Oct.	Nov.	Dec.
Mark	A	B	C	D	E	F	G	H	J	K	L	M

Plating material of a terminal. : Ni Plating + Au Plating.

A clearance between the soldering terminal portion and a print circuit board side should be less than 0.1mm.

TITLE DSX321G TYPE QUARTZ CRYSTAL SPECIFICATION		REMARK	
DATE 2014/04/04	SPEC. No. 1C212000BC0AK 1N212000BC0AK	REV.	PAGE 2 / 12

5. EMBOSS CARRIER TAPE & REEL

(1) Dimensions of embossed carrier tape

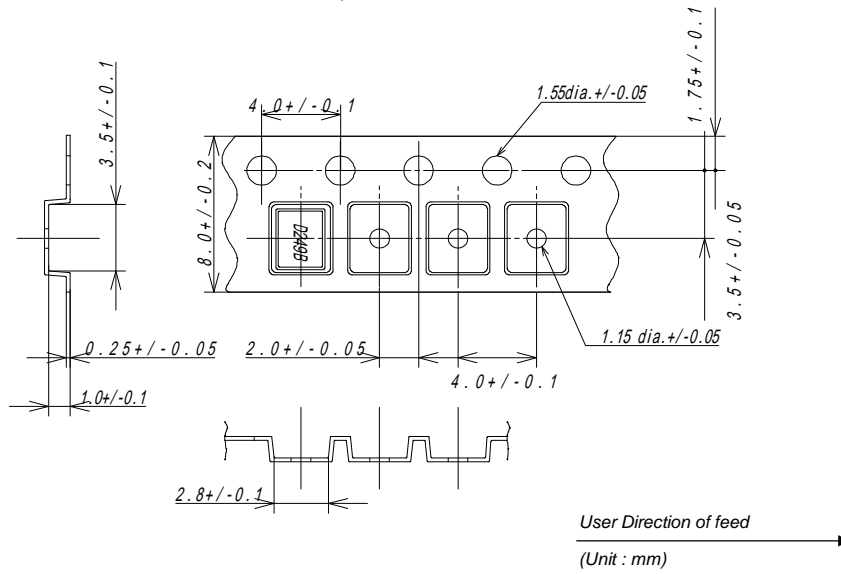

Figure-2

(2) Dimensions of tape reel

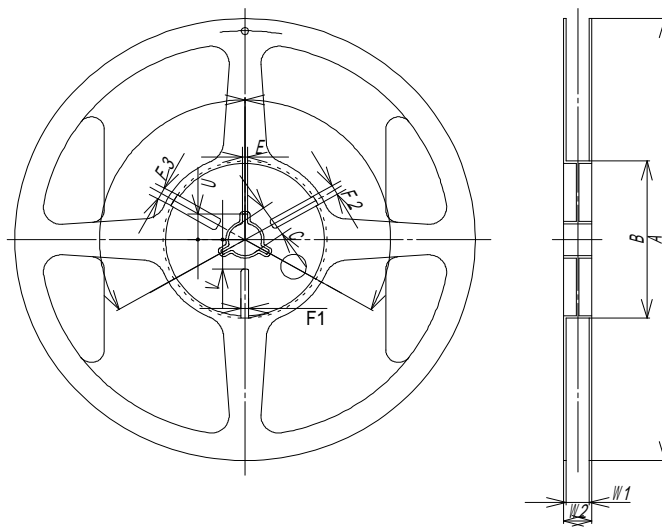

Figure-3

TITLE DSX321G TYPE QUARTZ CRYSTAL SPECIFICATION		REMARK	
DATE 2014/04/04	SPEC. No. 1C212000BC0AK 1N212000BC0AK	REV.	PAGE 3 / 12

(Unit:mm)

Item		Mark	Dimensions	Angle	
Flange	Diameter	A	Φ180	+0.0 / -3.0	
	Inside of Frange	W1	9.0	± 0.3	
	Outside of Frange	W2	11.4	± 1.0	
	Inside Diameter	B	Φ60	+1.0-0	
Center Core	Center Core Slit	Width	F1	3.0 ± 0.2	
			F2	4.0 ± 0.2	
			F3	5.0 ± 0.2	
	Center Core Slit	Length	V	11.9	+0.5 / -0.0
		Angle	θ	120°	
	Spindle Diameter		C	Φ13	± 0.2
	Key Seats	Width	E	2.0	± 0.5
		Length	U	10.5	± 0.4
Angle		θ	120°		

(3) Material of the reel

Reel	Polystyrene+Carbon(Black)
	Polystyrene(White)

(4) Storage condition

Temperature : +40 °C max.

Relative Humidity : 80% max.

(It is a guaranteed term because it obtains an excellent soldering: 6 months)

(5) Standard packing quantity

3,000 pcs/reel

(6) Material of the tape

Tape	Material
Carrier tape	Polystyrene+Carbon
Cover tape	Polyester

TITLE DSX321G TYPE QUARTZ CRYSTAL SPECIFICATION		REMARK	
DATE 2014/04/04	SPEC. No. 1C212000BC0AK 1N212000BC0AK	REV.	PAGE 4 / 12

(7) Label contents

- Type
- Our specification No.
- Your Part No.
- Lot No.
- Nominal Frequency
- Quantity
- Our Company Name
- Producing Country

Stick a label on the each reel.

(8) Taping dimension

Leader	Cover-tape	The length of cover-tape in the leader is more than 400mm including empty embossed area.
	Carrier-tape	After all products were packaged, must remain more than twenty pieces or 400mm empty area, which should be sealed by cover-tape.
Terminal	Cover-tape	The tip of cover-tape shall be fixed temporary by paper tape and roll around the core of reel one round.
	Carrier-tape	The empty embossed area which are sealed by cover-tape must remain more than 40mm.

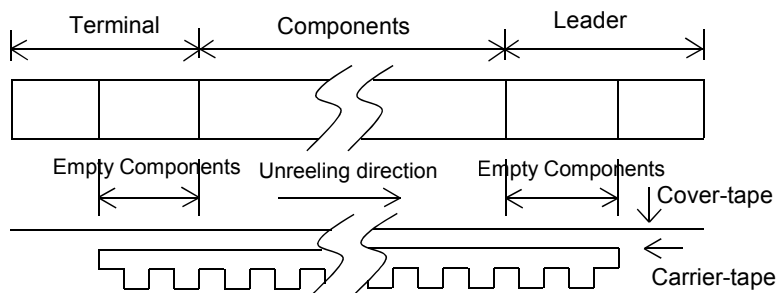

Figure-4

(9) Joint of tape

The carrier-tape and cover-tape should not be jointed.

(10) Release strength of cover tape

- It has to between 0.1 ~ 0.7N under following condition.
- Pulling direction 165 ~ 180 °
- Speed 300mm/min
- Otherwise unless specified.

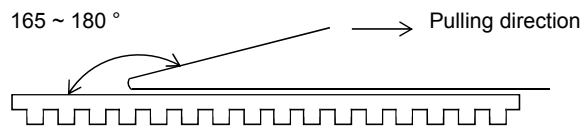

Figure-5

Other standards shall be based on JIS C 0806 .1990.

TITLE DSX321G TYPE QUARTZ CRYSTAL SPECIFICATION		REMARK	
DATE 2014/04/04	SPEC. No. 1C212000BC0AK 1N212000BC0AK	REV.	PAGE 5 / 12

6. PACKING

(1) STORAGE METHOD

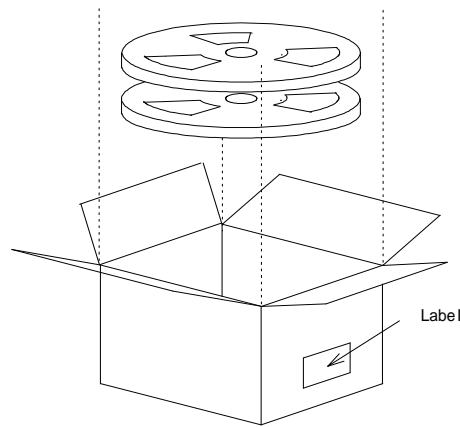

Label contents

- The type of product
- Lot No.
- Specification
- Quantity
- Shipment Day
- Remark

Figure-6

(2) BOX SIZE

From lot size packingsize shall be changed.

In the upper and lower part and the opening in box it shall be protected products using aircushion sheets.

<p>TITLE DSX321G TYPE QUARTZ CRYSTAL SPECIFICATION</p>	<p>REMARK</p>		
<p>DATE 2014/04/04</p>	<p>SPEC. No. 1C212000BC0AK 1N212000BC0AK</p>	<p>REV.</p>	<p>PAGE 6 / 12</p>

7. REFLOW CONDITIONS (REFERENCE)

During the solder reflow process, please complete within following temperature, period.
 Reflow soldering shall be allowed only 2 times.

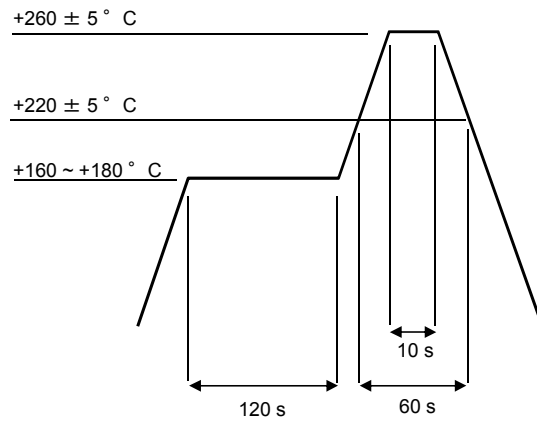

Total time : 240 s max.

Figure-7

HANDSOLDERING METHOD : +350 ± 10 °C , 3+1/-0s Each terminal once
 (Please take care so that a soldering iron should not touch a product directly.)

8. LAND PATTERN (REFERENCE)

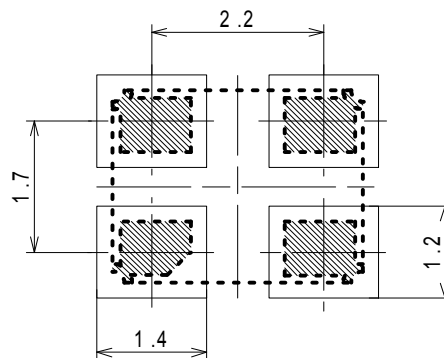

Unit : mm

Figure-8

TITLE DSX321G TYPE QUARTZ CRYSTAL SPECIFICATION		REMARK	
DATE 2014/04/04	SPEC. No. 1C212000BC0AK 1N212000BC0AK	REV.	PAGE 7 / 12

9. MECHANICAL ENDURANCE

(1) SHOCK (ACCELERATION)

After the following test, parts shall conform specification 11.C
 1000m/s² by 6ms X,Y,Z each axis (6 directions) , 3cycles

(2) SHOCK (MOUNTING DROP)

After the following test, parts shall conform specification 11.C
 3cycles(18times) drop from 150 cm heights to concrete.
 Further, parts shall be soldered on substrate, fixed Aluminum materials(about 100g).
 Substrate materials : Glass Epoxy
 1 cycle : each 1 times of 6 directions

(3) VIBRATION

After the following test, parts shall conform specification 11.C
 and no abnormal appearance shall be observed.
 Frequency of Vibration : 10 ~ 500 ~ 10 Hz
 Amplitude(p-p) : Sine waves of 1.5mm or 100m/s²
 Cycle : 11min
 Vibration axis : X.Y.Z
 Vibration period : 2 h for each axis

(4) SEAL

Less than 2.0×10⁻⁹ Pa m³/s by Helium leak detector.
 Also, no serial bubble is observed by Fluorocarbon tests.

(5) SOLDERABILITY

After the following test, more than 95% of terminal shall be covered by new solder.
 3 ± 0.5 s dip in +245 ± 5 °C solder.
 (Solder composition : Sn-3Ag-0.5Cu) (Use rosin type flux for solder.)

(6) RESISTANCE TO SOLDERING HEAT (REFLOW)

48 h past at room temperature from following test, parts shall conform specification 11.C
 perform the attached Reflow conditions to reference.

(7) RESISTANCE TO SOLDERING HEAT (HAND SOLDERING METHOD)

48 h past at room temperature from following test, parts shall conform specification 11.C
 +350 ± 10°C , 3+1/-0s Each terminal once.

(8) SUBSTRATE BENDING

After the following test, parts shall conform specification 11.C
 and no abnormality shall be observed in external appearance and sealing
 tightness and others shall be based on ET-7403 of EIAJ.
 Mount the specimen on substrate.
 Apply the following pressure

Direction : see right figure
 Speed : about 1.0 mm/s
 Hours : 5 ± 1 s
 Amount of substrate : 3 mm max.

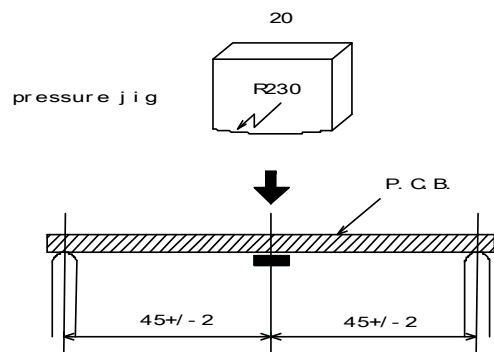

TITLE DSX321G TYPE QUARTZ CRYSTAL SPECIFICATION		REMARK	
DATE 2014/04/04	SPEC. No. 1C212000BC0AK 1N212000BC0AK	REV.	PAGE 8 / 12

(9) SHEAR

After the following test, parts shall conform specification 11.C and no abnormality shall be observed in external appearance and sealing tightness and others shall be based on ET-7403 of EIAJ.

Mount the specimen on substrate.

Apply the following pressure

- Weight : 10 N
- Hours : 10 ± 1 s
- Direction : see right figure

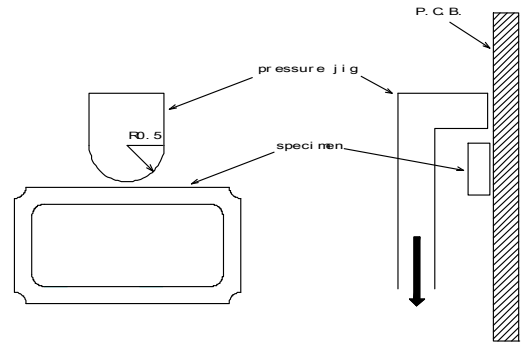

(10) BODY STRENGTH

After the following test, parts shall conform specification 11.C and no abnormality shall be observed in external appearance and sealing tightness and others shall be based on ET-7403 of EIAJ.

Mount the specimen on substrate.

Apply the following pressure

- Pressure jig : R0.5
- Weight : 10N
- Hours : 10 ± 1 s
- Direction : see right figure

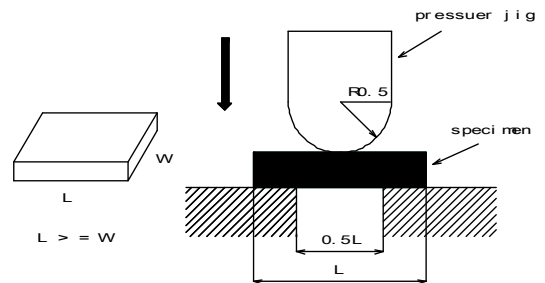

TITLE DSX321G TYPE QUARTZ CRYSTAL SPECIFICATION		REMARK	
DATE 2014/04/04	SPEC. No. 1C212000BC0AK 1N212000BC0AK	REV.	PAGE 9 / 12

10. ENVIRONMENTAL ENDURANCE

(1) LOW TEMPERATURE

2 h past at room temperature after following test, parts shall conform specification 11.C
 240 h , -40 ± 3 °C.

(2) HUMIDITY

2 h past at room temperature after following test, parts shall conform specification 11.D
 240 h , $+85 \pm 2$ °C , relative humidity $85 \pm 5\%$.

(3) HIGH TEMPERATURE

2 h past at room temperature after following test, parts shall conform specification 11.D
 240 h , $+85 \pm 2$ °C.

(4) TEMPERATURE CYCLE

2 h past at room temperature after 25 cycles of following test, parts shall conform specification 11.D

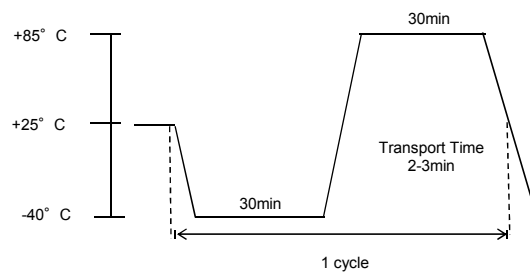

11. SPECIFICATION

Frequency Variation and Equivalent Resistance shall be within Table below after the reliability test.

Spec.	Frequency Variation	Equivalent Resistance
A	± 2 ppm	± 15 % or 2.0 Ω max. (Use larger specification)
B	± 5 ppm	± 15 % or 2.0 Ω max. (Use larger specification)
C	± 5 ppm	± 20 % or 3.0 Ω max. (Use larger specification)
D	± 10 ppm	± 20 % or 3.0 Ω max. (Use larger specification)
E	± 20 ppm	± 25 % or 10.0 Ω max. (Use larger specification)

TITLE DSX321G TYPE QUARTZ CRYSTAL SPECIFICATION		REMARK	
DATE 2014/04/04	SPEC. No. 1C212000BC0AK 1N212000BC0AK	REV.	PAGE 10 / 12

12. DSX321G TYPE QUARTZ CRYSTAL HANDLING INSTRUCTIONS

(1) SOLDERING

Please perform the attached Reflow conditions to reference within 2 times.

(2) MOUNT

Crystal products are designed to be compatible with automatic mounting.

Be sure to have a mounting test in advance by using the actual mounting machine and check that the characteristics of the products are not damaged by the automatic mounting.

In the process where the board is warped, such as board separation process, be careful that the warping does not influence the characteristics and soldering of crystal products.

Since mounting by Ultrasonic welding and processing have a possibility of an excessive vibration spreading inside a crystal resonator and becoming the cause of characteristic deterioration and not oscillating, it does not recommend.

Underfilling Material for DSX321G Types, KDS considers underfilling material such as heat-cured resin would not affect the characteristics of the DSX321G crystal mounted, however, we recommend the crystal be tested and checked in such a case prior to use so that there are the possibility that the crystal may have a cap off or a crack in the ceramic base.

(3) WASHING

About use of the washing liquid of a basin system, an alcoholic system, and a chlorofluorocarbon-replacing material system, it is checking that it is satisfactory.

However please consult in advance about other washing liquid.

Although the check about ultrasonic washing is performed,

since it is an examination with a simple substance,

the check for the second time by the use state is recommended.

(4) THE CAUTIONS ON USE

The piece of crystal it is processed very smaller than the conventional thing inside DSX321G series crystal unit may be damaged,

if excessive excitation electric power is applied.

Please use it below with the value specified on a catalog and specifications.

Please refrain from forming patterns between crystal land pattern's since there is a possibility to cause crack in base.

If the temperature is higher than +280 °C, there is a possibility for the sealing glass to remelt.

Avoid using the product at temperature higher than specified.

(5) HANDLING OF A PRODUCT

DSX321G series has sufficient intensity to fall and vibration.

However when too much shock is added according to a certain cause, the use after a characteristic check is recommended.

(6) STORAGE

Since the soldering nature of a terminal may be degraded,

please avoid storage in high temperature and a humid place.

Please keep it in the place which direct rays do not hit

and dew condensation does not generate.

TITLE DSX321G TYPE QUARTZ CRYSTAL SPECIFICATION	REMARK		
DATE	SPEC. No.	REV.	PAGE
2014/04/04	1C212000BC0AK 1N212000BC0AK		11 / 12

X-ON Electronics

Largest Supplier of Electrical and Electronic Components

Click to view similar products for [Crystals](#) category:

Click to view products by [KDS](#) manufacturer:

Other Similar products are found below :

[CX3225GB25000M0PPSZ1](#) [718-13.2-1](#) [MC405 32.0000K-R3:PURE SN](#) [7A-40.000MAAE-T](#) [FL2000085](#) [99-BU](#) [9B-15.360MBBK-B](#) [9C-7.680MBBK-T](#) [H10S-12.000-18-EXT-TR](#) [ABC2-6.000MHZ-D4Z-T](#) [ABLS-20.000MHZ-D2-T](#) [ABS071-32.768KHZ-6-T](#) [R38-32.768-12.5-5PPM-NPB](#) [BTD1062E05A-513](#) [21U15A-21.4MHZ](#) [RTX-781DF1-S-20.950](#) [LFXTAL066198Cutt](#) [9C-14.31818MBBK-T](#) [A-11.000MHZ-27](#) [ABL-27.000MHZ-B4Y-T](#) [ABM11-132-24.000MHZ-T3](#) [ABM3B1-25.000MHZ-D2Y-T](#) [SPT2A-.032768B](#) [SPT2A.032768G](#) [SSPT7F-9PF20-R](#) [FX325BS-38.88EEM1201](#) [LFXTAL065253Cutt](#) [LFXTAL066431Cutt](#) [XT9S20ANA14M7456](#) [XT9SNLANA16M](#) [646G-24-2](#) [7A-24.576MBBK-T](#) [7B-30.000MBBK-T](#) [7A-14.31818MBBK-T](#) [6504-202-1501](#) [6526-202-1501](#) [ABLS-12.000MHZ-B2Y-T](#) [ABLS-10.000MHZ-D3W-T](#) [7A-10.000MBBK-T](#) [SG636PCE-20.000MC](#) [3404](#) [E1SAA18-25.000M TR](#) [CM315D32768EZFT](#) [C1E-24.000-7-2020-R](#) [C1E-19.200-12-1530-X-R](#) [C1E-16.000-12-1530-X-R](#) [FL5000014](#) [EUCA18-3.1872M](#) [FX0800015](#) [425F35E027M0000](#)