

General Description

KEC Field Stop Trench IGBTs offer low switching losses, high energy efficiency and short circuit ruggedness.

It is designed for applications such as motor control, uninterrupted power supplies(UPS), general inverters.

FEATURES

- High speed switching
- High system efficiency
- Short Circuit Withstand Times 10us
- Extremely enhanced avalanche capability

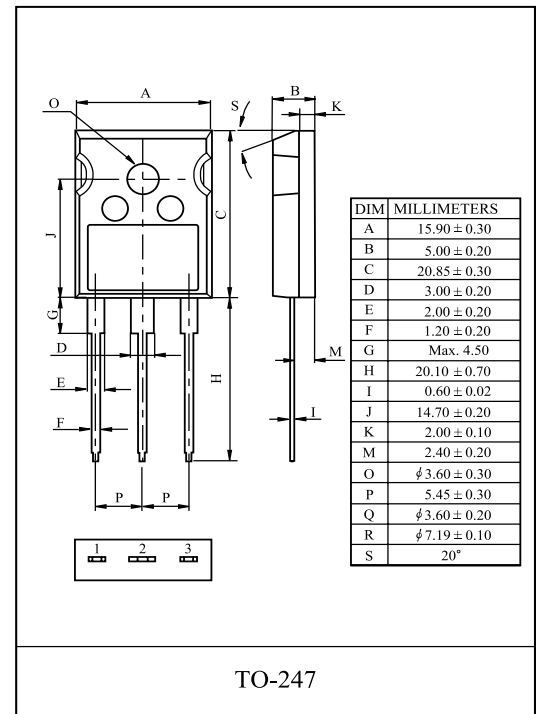

MAXIMUM RATING (Ta=25)

| CHARACTERISTIC | SYMBOL | RATING | UNIT |
|----------------------------------|-------------------|--------------|-------|
| Collector-Emitter Voltage | V _{CES} | 1200 | V |
| Gate-Emitter Voltage | V _{GES} | ± 20 | V |
| Collector Current | I _C | @Tc=25 | 80 A |
| | | @Tc=100 | 40 A |
| Pulsed Collector Current | I _{CM} * | 120 | A |
| Diode Continuous Forward Current | I _F | 40 | A |
| Diode Maximum Forward Current | I _{FM} | 160 | A |
| Maximum Power Dissipation | P _D | @Tc=25 | 357 W |
| | | @Tc=100 | 140 W |
| Maximum Junction Temperature | T _j | 150 | |
| Storage Temperature Range | T _{stg} | -55 to + 150 | |

*Repetitive rating : Pulse width limited by max. junction temperature

THERMAL CHARACTERISTIC

| CHARACTERISTIC | SYMBOL | MAX. | UNIT |
|--|-------------------|------|------|
| Thermal Resistance, Junction to Case (IGBT) | R _{thJC} | 0.35 | /W |
| Thermal Resistance, Junction to Case (DIODE) | R _{thJC} | 1.1 | /W |
| Thermal Resistance, Junction to Ambient | R _{thJA} | 40 | /W |

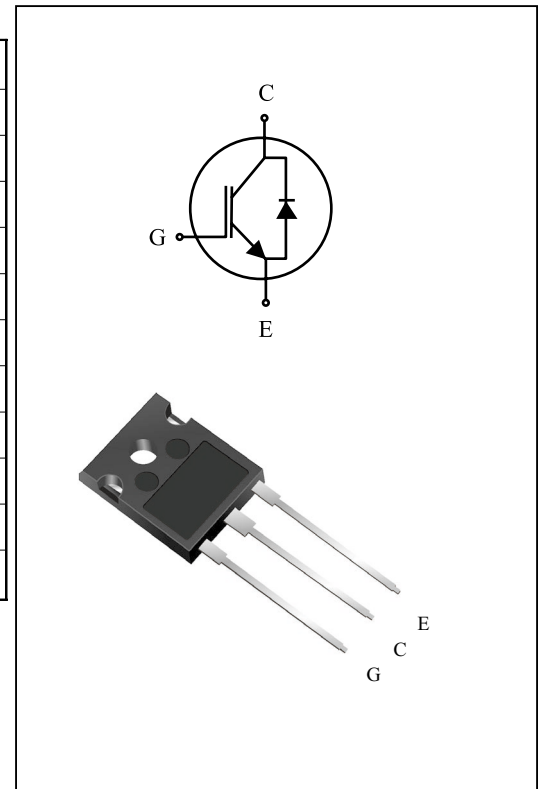

KGF40N120KDA

ELECTRICAL CHARACTERISTICS (Ta=25)

| CHARACTERISTIC | SYMBOL | TEST CONDITION | MIN. | TYP. | MAX. | UNIT | |
|--------------------------------------|---------------|--|---|------|-----------|------|---------|
| Static | | | | | | | |
| Collector-Emitter Breakdown Voltage | BV_{CES} | $V_{GE}=0V, I_C=1mA$ | 1200 | - | - | V | |
| Collector Cut-off Current | I_{CES} | $V_{GE}=0V, V_{CE}=1200V$ | - | - | 1.0 | mA | |
| Gate Leakage Current | I_{GES} | $V_{CE}=0V, V_{GE}=\pm 20V$ | - | - | ± 100 | nA | |
| Gate Threshold Voltage | $V_{GE(th)}$ | $V_{GE}=V_{CE}, I_C=40mA$ | 4.5 | 6.0 | 7.5 | V | |
| Collector-Emitter Saturation Voltage | $V_{CE(sat)}$ | $V_{GE}=15V, I_C=40A$ | - | 1.9 | 2.25 | V | |
| | | $V_{GE}=15V, I_C=40A, T_C = 125$ | - | 2.2 | - | V | |
| | | $V_{GE}=15V, I_C=80A$ | - | 2.5 | - | V | |
| Dynamic | | | | | | | |
| Total Gate Charge | Q_g | $V_{CC}=600V, V_{GE}=15V, I_C= 40A$ | - | 230 | 350 | nC | |
| Gate-Emitter Charge | Q_{ge} | | - | 30 | - | nC | |
| Gate-Collector Charge | Q_{gc} | | - | 110 | - | nC | |
| Turn-On Delay Time | $t_{d(on)}$ | $V_{CC}=600V, I_C=40A, V_{GE}=15V, R_G=10$ Inductive Load, $T_C = 25$ | - | 60 | - | ns | |
| Rise Time | t_r | | - | 45 | - | ns | |
| Turn-Off Delay Time | $t_{d(off)}$ | | - | 310 | - | ns | |
| Fall Time | t_f | | - | 70 | - | ns | |
| Turn-On Switching Loss | E_{on} | | - | 3.5 | 5.2 | mJ | |
| Turn-Off Switching Loss | E_{off} | | - | 1.9 | 2.8 | mJ | |
| Total Switching Loss | E_{ts} | | - | 5.4 | 8.0 | mJ | |
| Turn-On Delay Time | $t_{d(on)}$ | | $V_{CC}=600V, I_C=40A, V_{GE}=15V, R_G=10$ Inductive Load, $T_C = 125$ | - | 60 | - | ns |
| Rise Time | t_r | | | - | 50 | - | ns |
| Turn-Off Delay Time | $t_{d(off)}$ | | | - | 350 | - | ns |
| Fall Time | t_f | - | | 175 | - | ns | |
| Turn-On Switching Loss | E_{on} | - | | 4.3 | 6.4 | mJ | |
| Turn-Off Switching Loss | E_{off} | - | | 3.0 | 4.5 | mJ | |
| Total Switching Loss | E_{ts} | - | | 7.3 | 10.9 | mJ | |
| Input Capacitance | C_{ies} | $V_{CE}=30V, V_{GE}=0V, f=1MHz$ | - | 4800 | - | pF | |
| Output Capacitance | C_{oes} | | - | 195 | - | pF | |
| Reverse Transfer Capacitance | C_{res} | | - | 135 | - | pF | |
| Short Circuit Withstand Time | t_{sc} | | $V_{CC}=600V, V_{GE}=15V, T_C=100$ | 10 | - | - | μs |

Marking

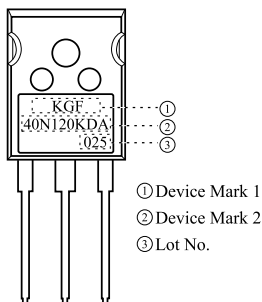

KGF40N120KDA

ELECTRICAL CHARACTERISTIC OF DIODE

| CHARACTERISTIC | SYMBOL | TEST CONDITION | | MIN. | TYP. | MAX. | UNIT |
|-------------------------------------|----------|-------------------------------------|-------------|------|------|------|------|
| Diode Forward Voltage | V_F | $I_F = 40A$ | $T_C = 25$ | - | 2.2 | 2.6 | V |
| | | | $T_C = 125$ | - | 1.9 | - | |
| Diode Reverse Recovery Time | t_{rr} | $I_F = 40A$ | $T_C = 25$ | - | 360 | 520 | ns |
| | | | $T_C = 125$ | - | 460 | - | |
| Diode Peak Reverse Recovery Current | I_{rr} | $I_F = 40A$ $di/dt = 200A/\mu s$ | $T_C = 25$ | - | 16 | 21 | A |
| | | | $T_C = 125$ | - | 19 | - | |
| Diode Reverse Recovery Charge | Q_{rr} | $I_F = 40A$ $di/dt = 200A/\mu s$ | $T_C = 25$ | - | 2800 | 4200 | nC |
| | | | $T_C = 125$ | - | 5200 | - | |

KGF40N120KDA

Fig 1. Saturation Voltage Characteristics

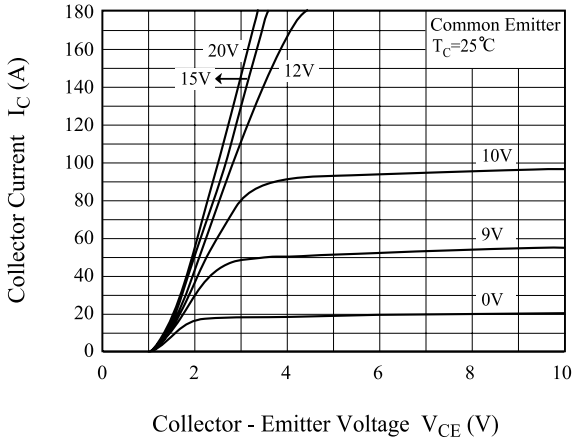

Fig 2. Saturation Voltage Characteristics

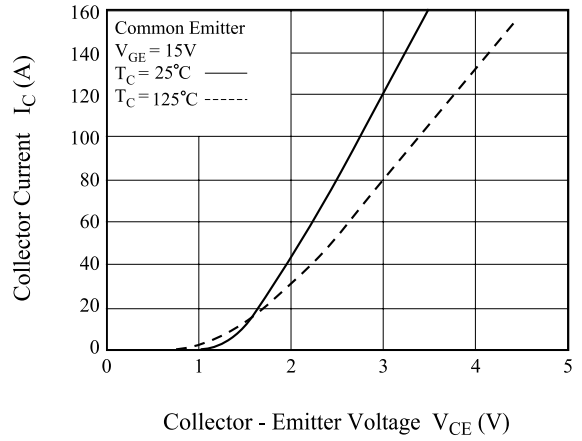

Fig 3. Saturation Voltage vs. Case Temperature

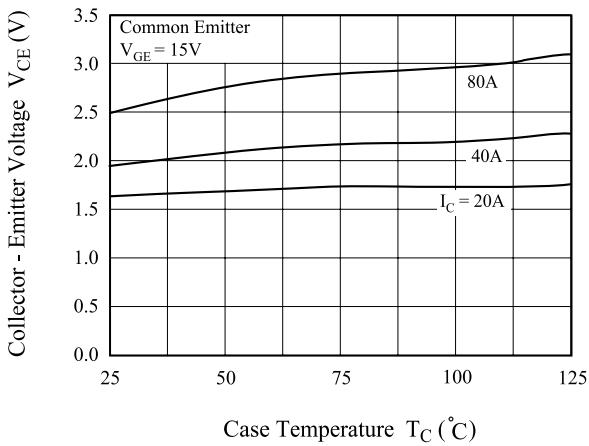

Fig 4. Saturation Voltage vs. V_{GE}

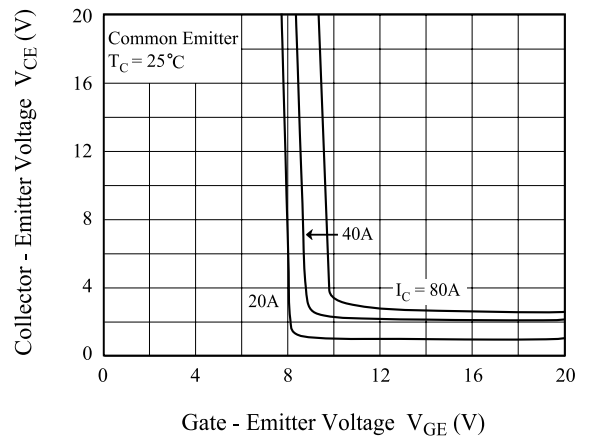

Fig 5. Saturation Voltage vs. V_{GE}

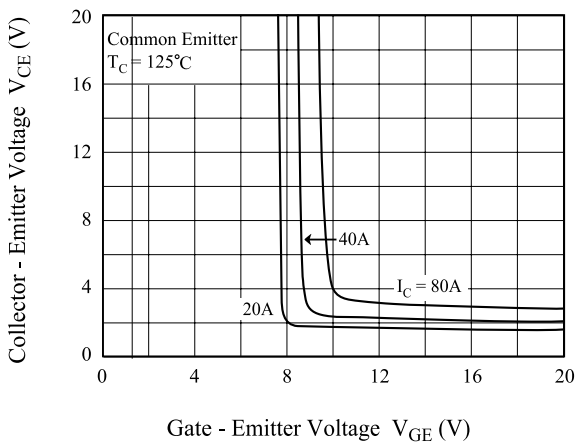
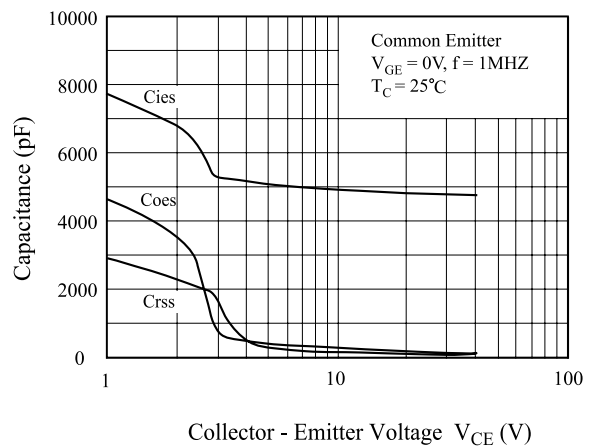

Fig 6. Capacitance Characteristics



KGF40N120KDA

Fig 7. Turn-On Characteristics vs. Gate Resistance

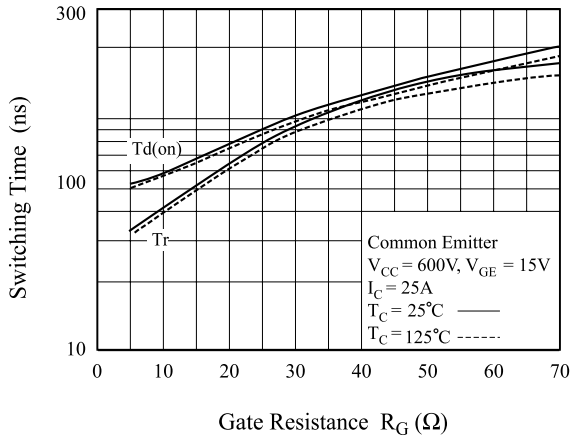

Fig 8. Turn-Off Characteristics vs. Gate Resistance

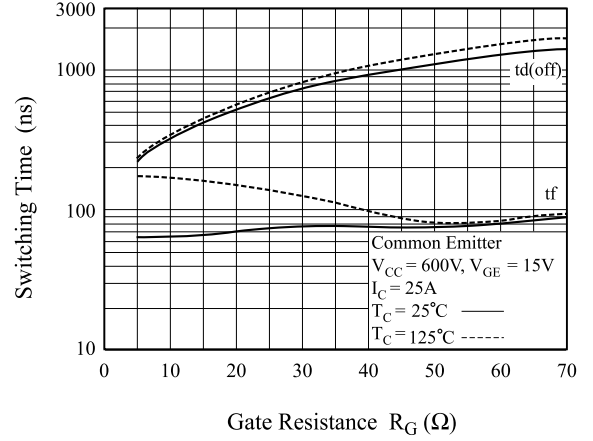

Fig 9. Switching Loss vs. Gate Resistance

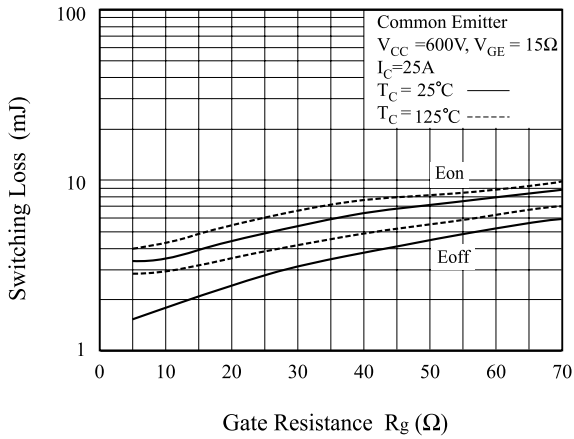

Fig 10. Turn-On Characteristics vs Collector Current

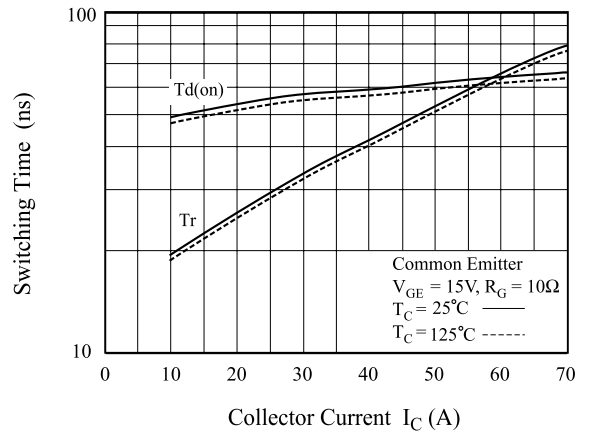

Fig 11. Turn-Off Characteristics vs Collector Current

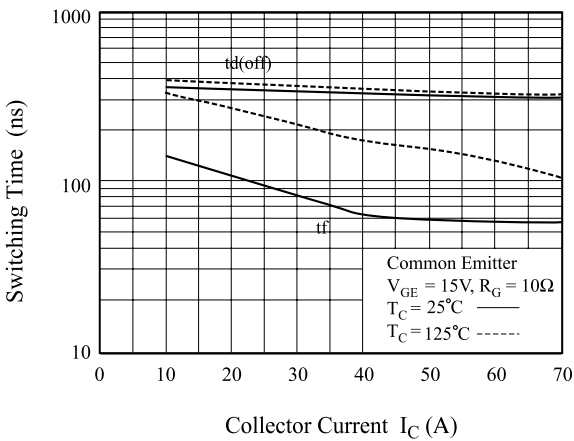
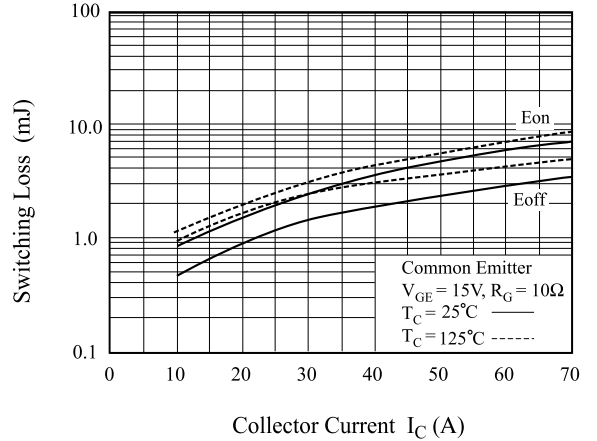

Fig 12. Switching Loss vs. Collector Current



KGF40N120KDA

Fig 13. Gate Charge Characteristics

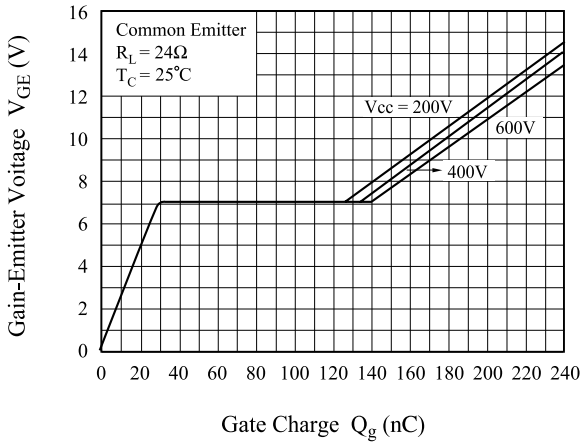

Fig 14. SOA Characteristics

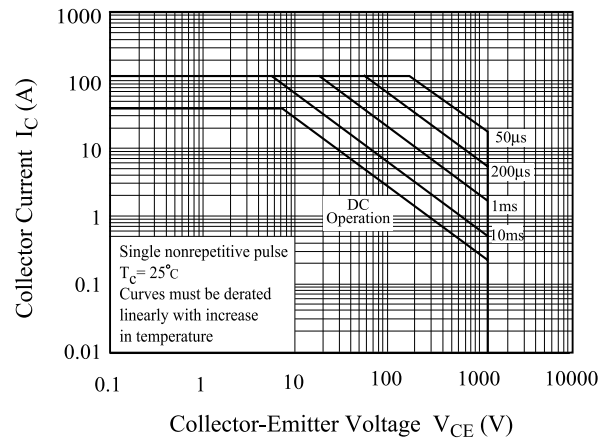

Fig 15. Turn-Off SOA

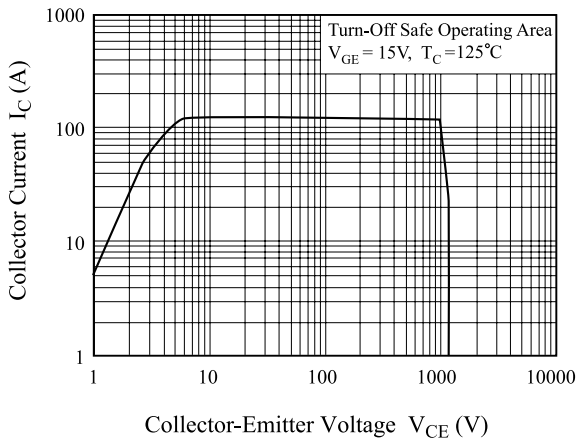
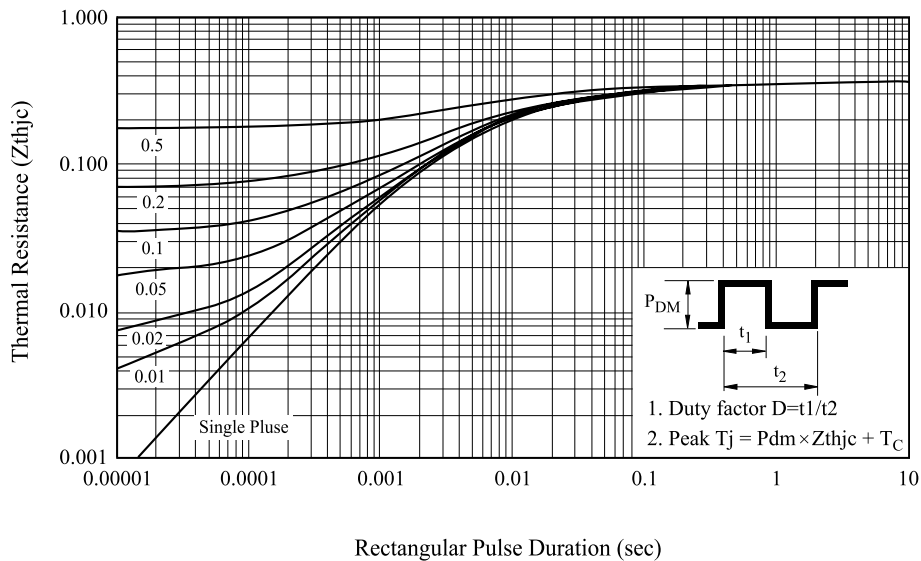

Fig 16. Transient Thermal Impedance of IGBT



KGF40N120KDA

Fig 17. Forward Characteristics

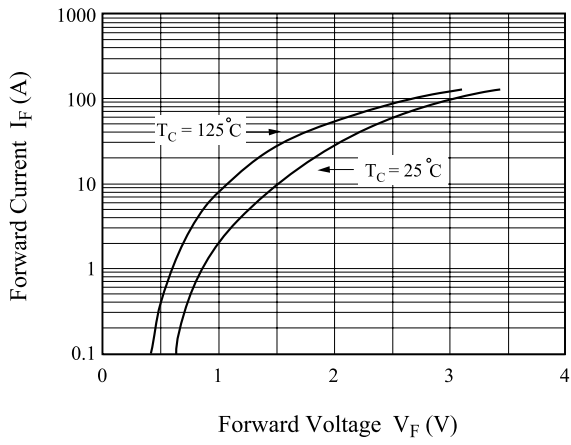

Fig 18. Reverse Recovery Current

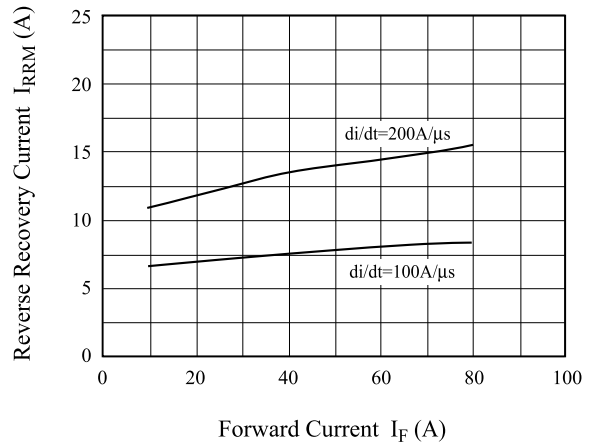
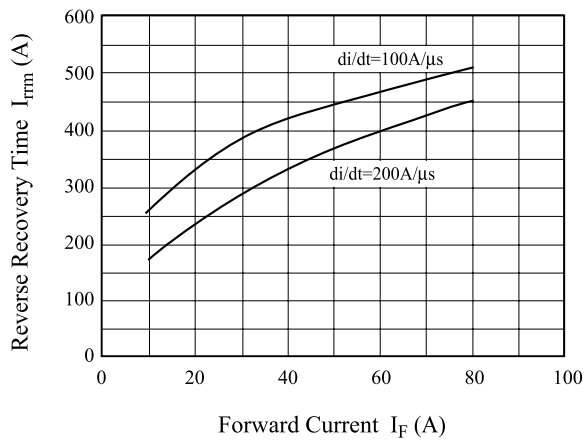

Fig 19. Reverse Recovery Time



KGF40N120KDA

Fig 21. Switching Test Circuit

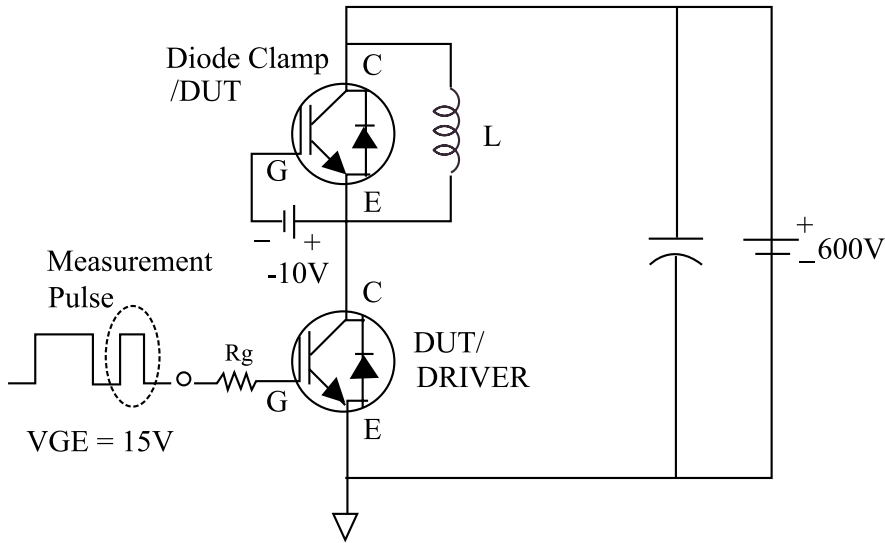

Fig 22. Definition Switching Time & Loss

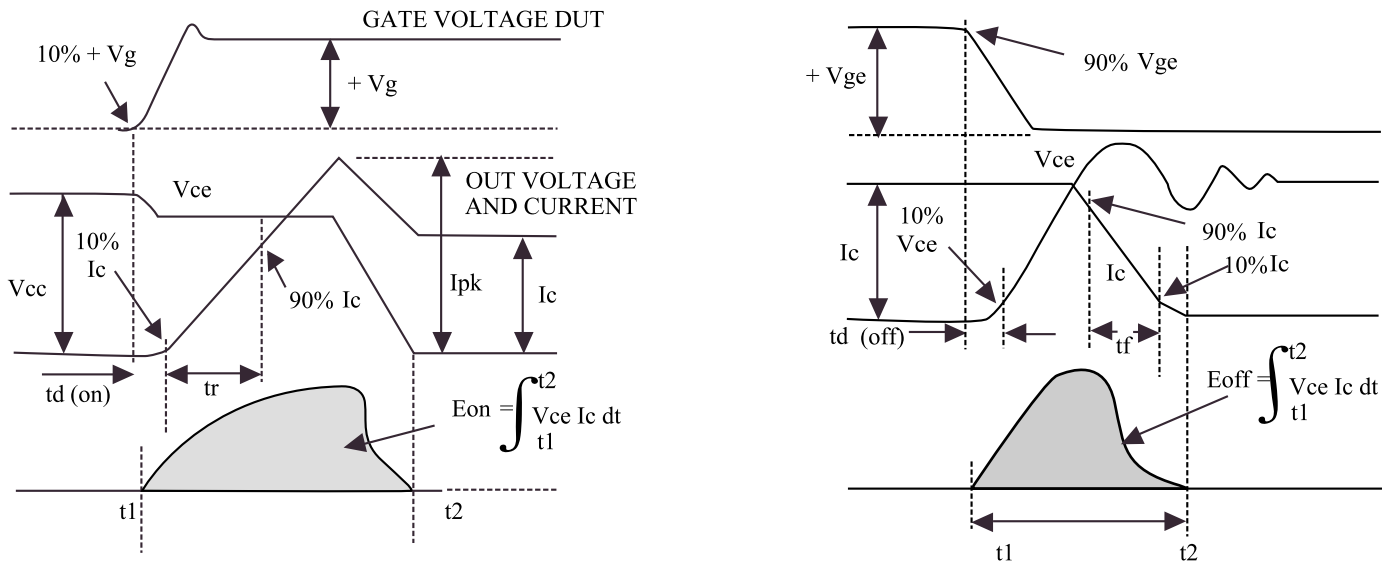
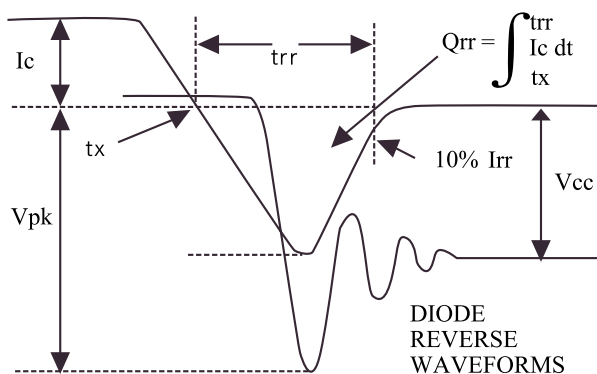

Fig 23. Definition Diode Switching Time



X-ON Electronics

Largest Supplier of Electrical and Electronic Components

Click to view similar products for [IGBT Transistors](#) category:

Click to view products by [KEC](#) manufacturer:

Other Similar products are found below :

[748152A](#) [FGH60T65SHD_F155](#) [APT100GT60B2RG](#) [APT13GP120BG](#) [APT20GN60BG](#) [APT20GT60BRDQ1G](#) [APT25GN120B2DQ2G](#)
[APT35GA90BD15](#) [APT36GA60BD15](#) [APT40GP60B2DQ2G](#) [APT40GP90B2DQ2G](#) [APT50GN120B2G](#) [APT50GT60BRG](#)
[APT64GA90B2D30](#) [APT70GR120J](#) [NGTB10N60FG](#) [NGTB30N60L2WG](#) [IGP30N60H3XKSA1](#) [STGB15H60DF](#) [STGFW20V60DF](#)
[STGFW30V60DF](#) [STGFW40V60F](#) [STGWA25H120DF2](#) [FGB3236_F085](#) [APT25GN120BG](#) [APT25GR120S](#) [APT30GN60BDQ2G](#)
[APT30GN60BG](#) [APT30GP60BG](#) [APT30GS60BRDQ2G](#) [APT30N60BC6](#) [APT35GP120JDQ2](#) [APT36GA60B](#) [APT45GR65B2DU30](#)
[APT50GP60B2DQ2G](#) [APT68GA60B](#) [APT70GR65B](#) [APT70GR65B2SCD30](#) [GT50JR22\(STA1ES\)](#) [TIG058E8-TL-H](#) [IDW40E65D2](#)
[SGB15N120ATMA1](#) [NGTB50N60L2WG](#) [STGB10H60DF](#) [STGB20V60F](#) [STGB40V60F](#) [STGFW80V60F](#) [IGW40N120H3FKSA1](#)
[RJH60D7BDPQ-E0#T2](#) [APT40GR120B](#)