

## General Description

KEC Field Stop Trench IGBTs offer low switching losses, high energy efficiency and short circuit ruggedness.

It is designed for applications such as Power Factor Correction(PFC), Inverterized MWO, Welder, Uninterrupted Power Supplies(UPS) and General Converters.

## FEATURES

- High speed switching
- High ruggedness, temperature stable behavior
- Extremely enhanced avalanche capability

## ORDERING INFORMATION

FULL NAME	PACKAGE	SUFFIX
KGF60N65KDF-U/H	TO-247	-
KGF60N65KDF-U/HE	TO-247(E)	Added code "E" to TO-247(E)

## MAXIMUM RATING (Ta=25°C)

CHARACTERISTIC	SYMBOL	RATING	UNIT
Collector-Emitter Voltage	$V_{CES}$	650	V
Gate-Emitter Voltage	$V_{GES}$	$\pm 20$	V
Collector Current	@Tc=25°C	120	A
	@Tc=100°C	60	A
Pulsed Collector Current	$I_{CM}^*$	180	A
Diode Continuous Forward Current	@Tc=100°C	$I_F$	60 A
Diode Maximum Forward Current		$I_{FM}$	120 A
Maximum Power Dissipation	@Tc=25°C	$P_D$	340 W
	@Tc=100°C		170 W
Maximum Junction Temperature	$T_J$	175	°C
Storage Temperature Range	$T_{stg}$	-55 to + 175	°C

\*Repetitive rating : Pulse width limited by max. junction temperature

## THERMAL CHARACTERISTIC

CHARACTERISTIC	SYMBOL	MAX.	UNIT
Thermal Resistance, Junction to Case (IGBT)	$R_{thJC}$	0.44	°C/W
Thermal Resistance, Junction to Case (DIODE)	$R_{thJC}$	1.3	°C/W
Thermal Resistance, Junction to Ambient	$R_{thJA}$	40	°C/W

## PIN CONNECTION

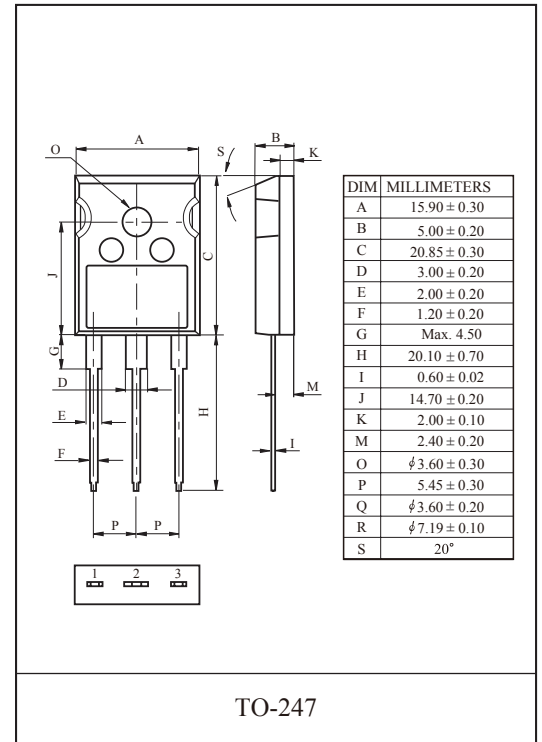
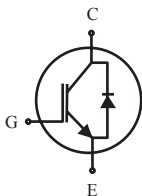

TO-247

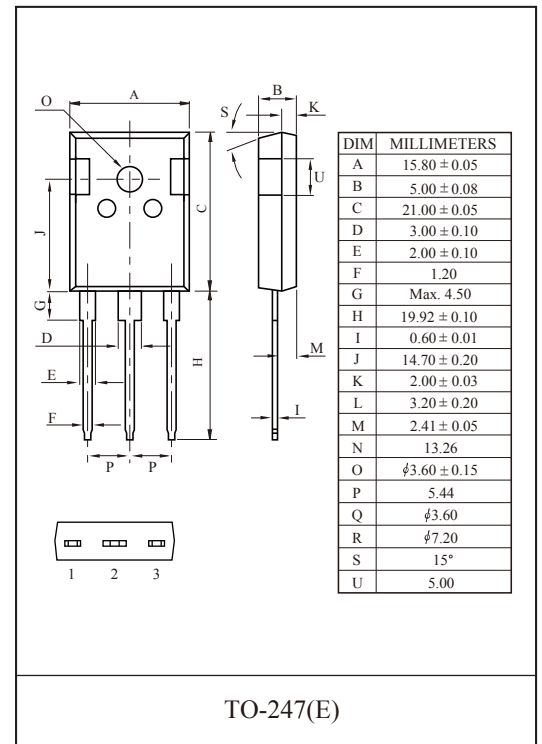

TO-247(E)

# KGF60N65KDF

## ELECTRICAL CHARACTERISTICS (Ta=25°C )

CHARACTERISTIC	SYMBOL	TEST CONDITION	MIN.	TYP.	MAX.	UNIT	
<b>Static</b>							
Collector-Emitter Breakdown Voltage	$BV_{CES}$	$V_{GE}=0V, I_C=250\mu A$	650	-	-	V	
Collector Cut-off Current	$I_{CES}$	$V_{GE}=0V, V_{CE}=650V$	-	-	250	$\mu A$	
Gate Leakage Current	$I_{GES}$	$V_{CE}=0V, V_{GE}=\pm 20V$	-	-	$\pm 100$	nA	
Gate Threshold Voltage	$V_{GE(th)}$	$V_{GE}=V_{CE}, I_C=1mA$	4.3	5.4	6.5	V	
Collector-Emitter Saturation Voltage	$V_{CE(sat)}$	$V_{GE}=15V, I_C=60A$	-	1.77	2.2	V	
		$V_{GE}=15V, I_C=120A$	-	2.47	-	V	
		$V_{GE}=15V, I_C=60A, T_C = 150^\circ C$	-	2.12	-	V	
<b>Dynamic</b>							
Total Gate Charge	$Q_g$	$V_{CC}=400V, V_{GE}=15V, I_C=60A$	-	105	-	nC	
Gate-Emitter Charge	$Q_{ge}$		-	20	-	nC	
Gate-Collector Charge	$Q_{gc}$		-	52	-	nC	
Turn-On Delay Time	$t_{d(on)}$	$V_{CC}=400V, V_{GE}=15V, I_C=60A, R_G=10\Omega$ Inductive Load, $T_C = 25^\circ C$ (Note 1)	-	56	-	ns	
Rise Time	$t_r$		-	101	-	ns	
Turn-Off Delay Time	$t_{d(off)}$		-	173	-	ns	
Fall Time	$t_f$		-	34	-	ns	
Turn-On Switching Loss	$E_{on}$		-	3.1	-	mJ	
Turn-Off Switching Loss	$E_{off}$		-	1.1	-	mJ	
Total Switching Loss	$E_{ts}$		-	4.2	-	mJ	
Turn-On Delay Time	$t_{d(on)}$		$V_{CC}=400V, V_{GE}=15V, I_C=60A, R_G=10\Omega$ Inductive Load, $T_C = 150^\circ C$ (Note 1)	-	56	-	ns
Rise Time	$t_r$			-	100	-	ns
Turn-Off Delay Time	$t_{d(off)}$			-	216	-	ns
Fall Time	$t_f$	-		42	-	ns	
Turn-On Switching Loss	$E_{on}$	-		3.2	-	mJ	
Turn-Off Switching Loss	$E_{off}$	-		1.7	-	mJ	
Total Switching Loss	$E_{ts}$	-		4.9	-	mJ	
Input Capacitance	$C_{ies}$	$V_{CE}=30V, V_{GE}=0V, f=1MHz$	-	2981	-	pF	
Output Capacitance	$C_{oes}$		-	158	-	pF	
Reverse Transfer Capacitance	$C_{res}$		-	34	-	pF	
Short Circuit Withstand Time	$t_{sc}$	$V_{CC}=300V, V_{GE}=15V, T_C=100^\circ C$	5	-	-	$\mu s$	

Note 1 : Energy loss include tail current and diode reverse recovery.

### Marking

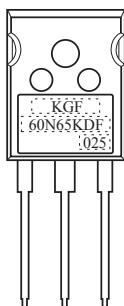

- ① Device Mark 1
- ② Device Mark 2
- ③ Lot No

# KGF60N65KDF

## ELECTRICAL CHARACTERISTIC OF DIODE

CHARACTERISTIC	SYMBOL	TEST CONDITION		MIN.	TYP.	MAX.	UNIT
Diode Forward Voltage	$V_F$	$I_F = 60A$	$T_C = 25^\circ C$	-	2.16	-	V
			$T_C = 150^\circ C$	-	2.2	-	
Diode Reverse Recovery Time	$t_{rr}$	$V_{CC} = 400V$	$T_C = 25^\circ C$	-	116	-	ns
			$T_C = 150^\circ C$	-	148.5	-	
Diode Peak Reverse Recovery Current	$I_{rr}$	$I_F = 60A$	$T_C = 25^\circ C$	-	9.7	-	A
			$T_C = 150^\circ C$	-	12.7	-	
Diode Reverse Recovery Charge	$Q_{rr}$	$di/dt = 300A/\mu s$	$T_C = 25^\circ C$	-	0.6	-	$\mu C$
			$T_C = 150^\circ C$	-	1.3	-	

# KGF60N65KDF

Fig 1. Saturation Voltage Characteristics

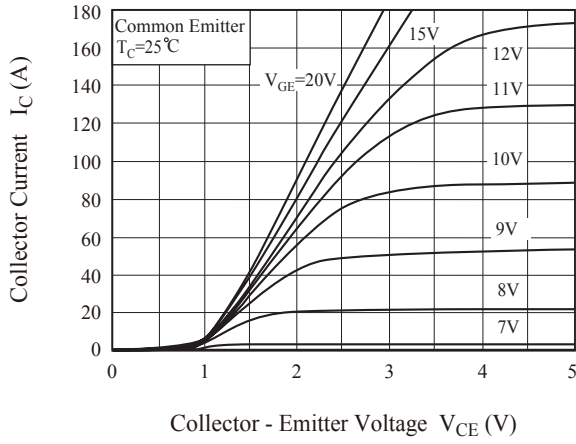

Fig 2. Saturation Voltage Characteristics

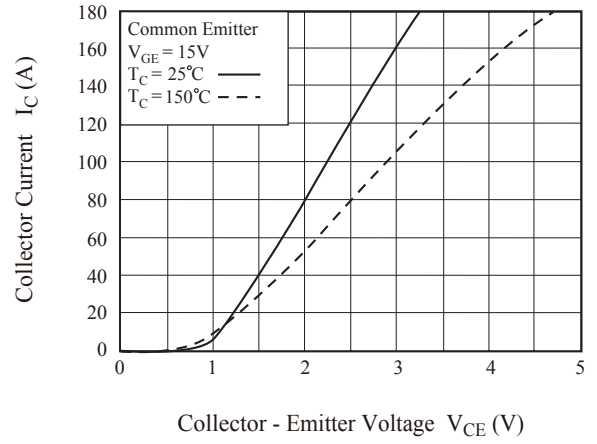

Fig 3. Saturation Voltage vs. Case Temperature

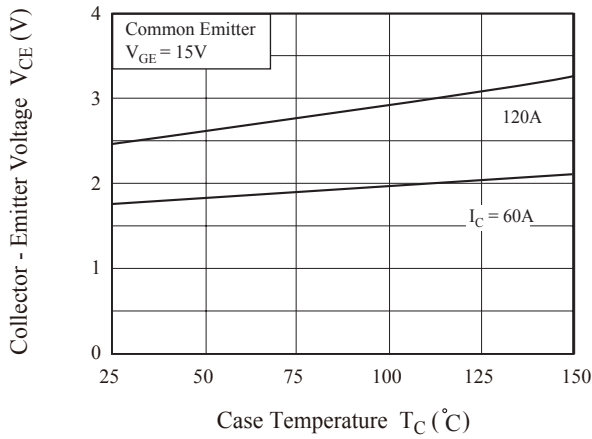

Fig 4. Saturation Voltage vs.  $V_{GE}$

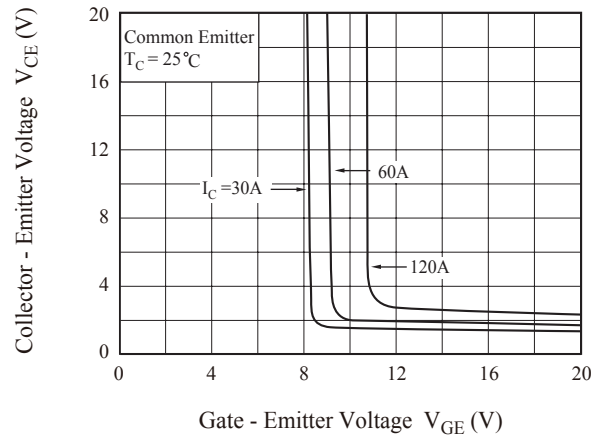

Fig 5. Saturation Voltage vs.  $V_{GE}$

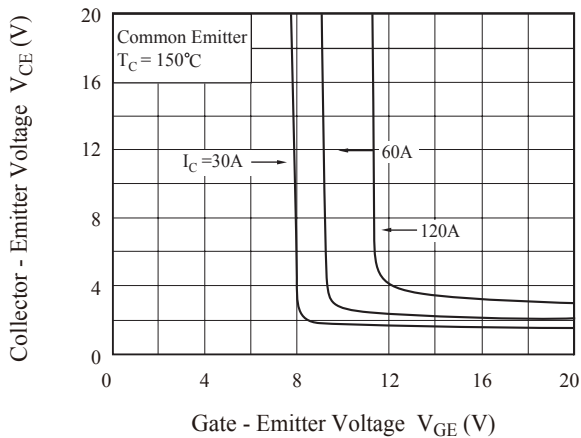

Fig 6. Capacitance Characteristics

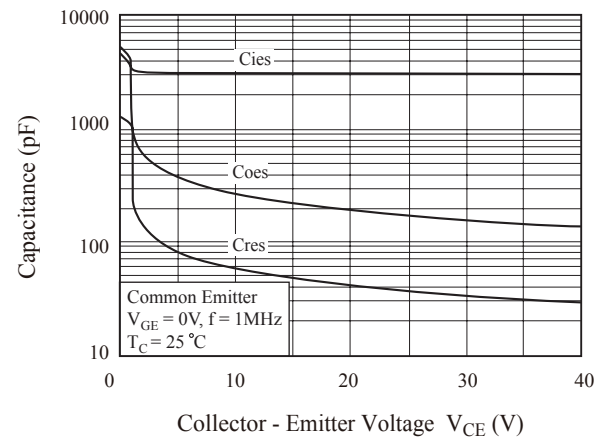

Fig 7. Turn-On Characteristics vs. Gate Resistance

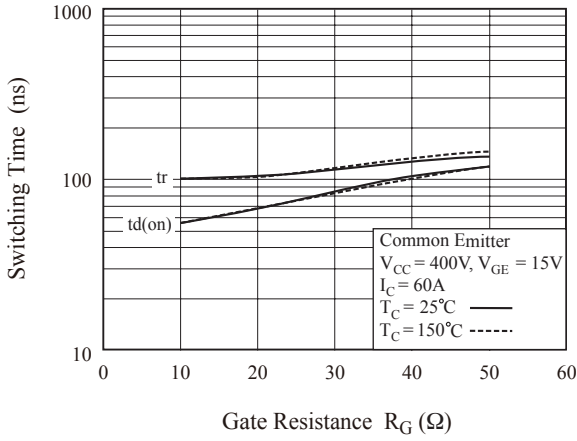

Fig 8. Turn-Off Characteristics vs. Gate Resistance

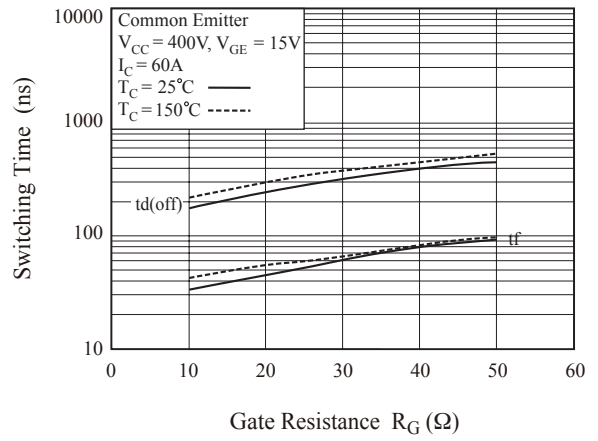

Fig 9. Switching Loss vs. Gate Resistance

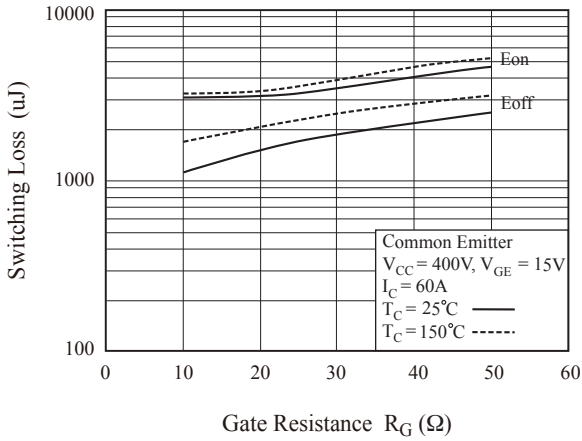

Fig 10. Turn-On Characteristics vs. Collector Current

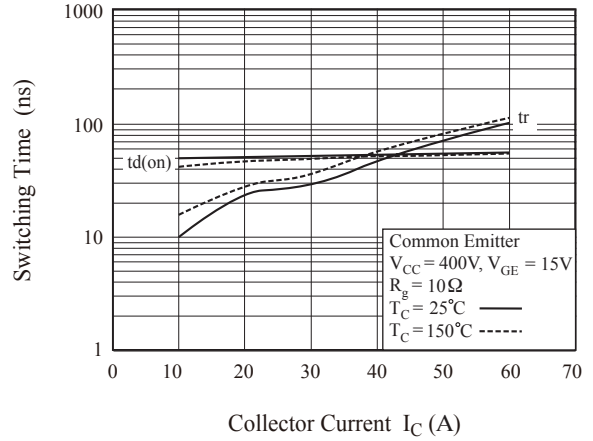

Fig 11. Turn-Off Characteristics vs. Collector Current

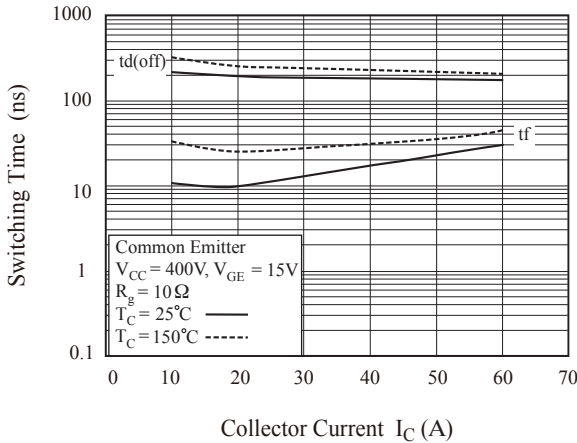
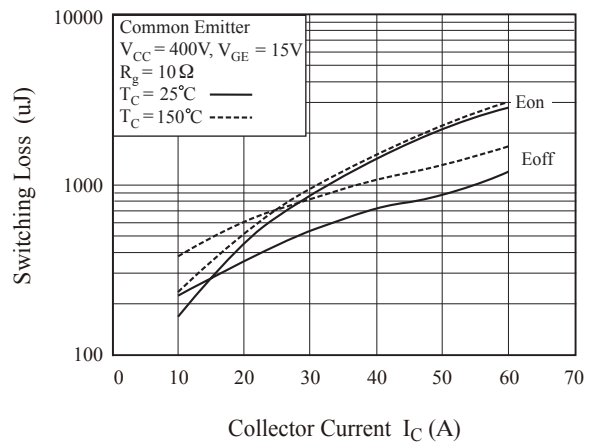

Fig 12. Switching Loss vs. Collector Current



# KGF60N65KDF

Fig 13. Gate Charge Characteristics

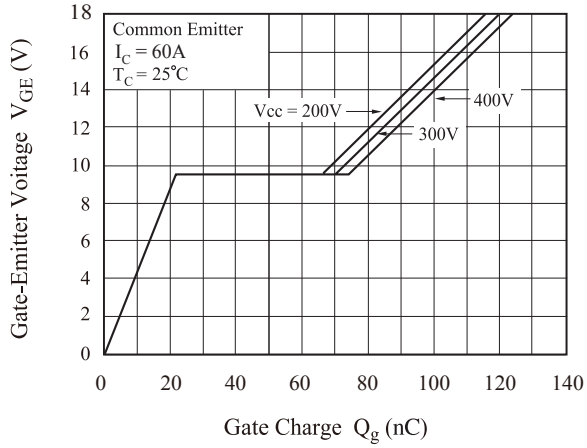

Fig 14. SOA Characteristics

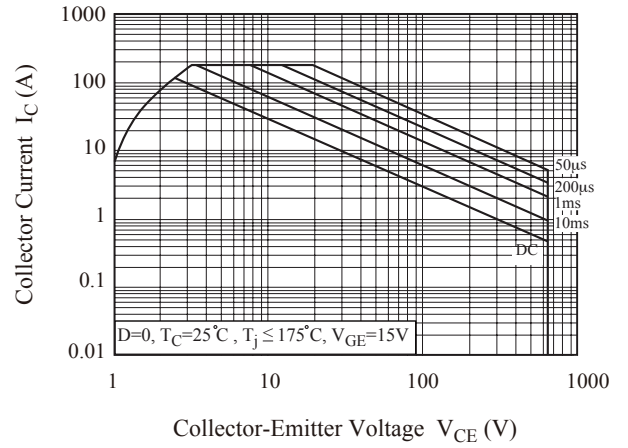
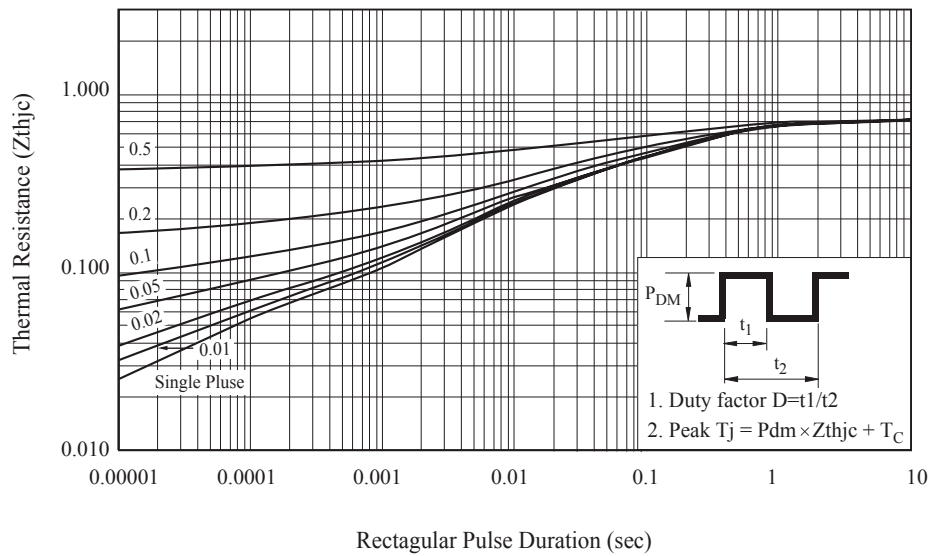

Fig 15. Transient Thermal Impedance of IGBT



# KGF60N65KDF

Fig 16. Forward Characteristics

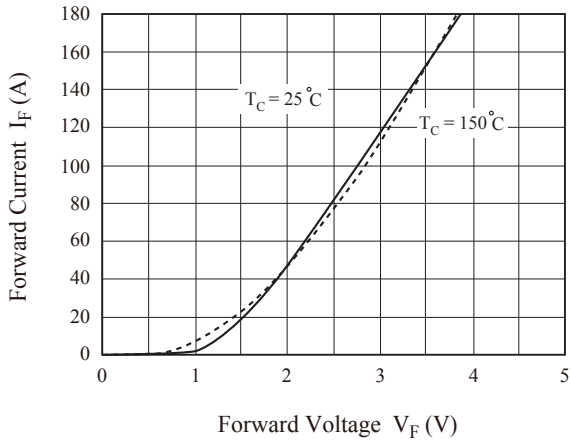

Fig 17. Reverse Recovery Current

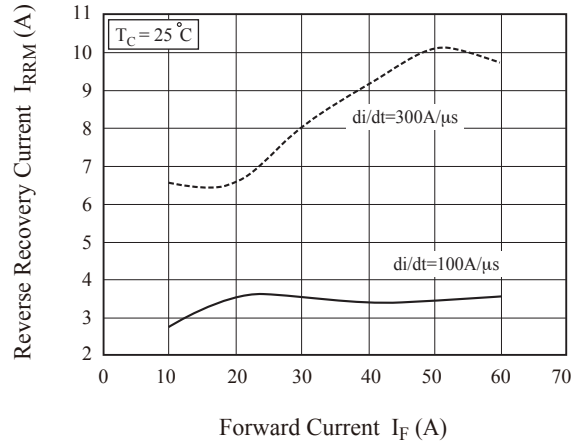

Fig 18. Reverse Recovery Time

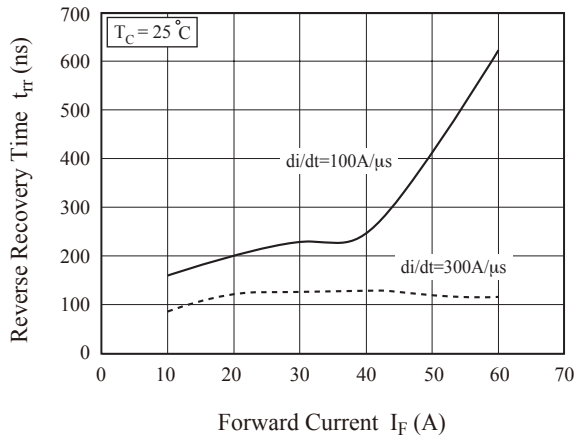

Fig 19. Switching Test Circuit

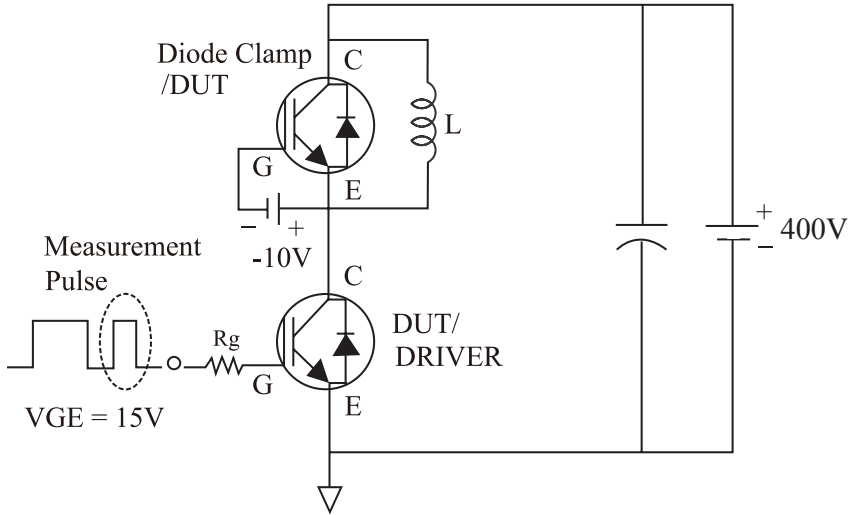

Fig 20. Definition Switching Time & Loss

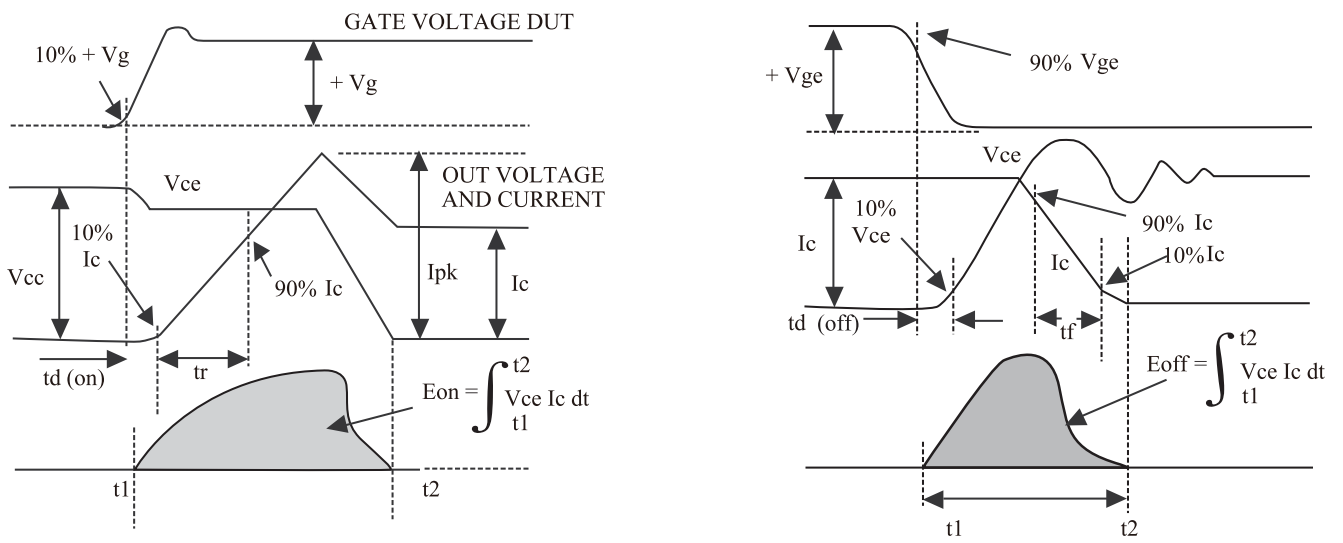
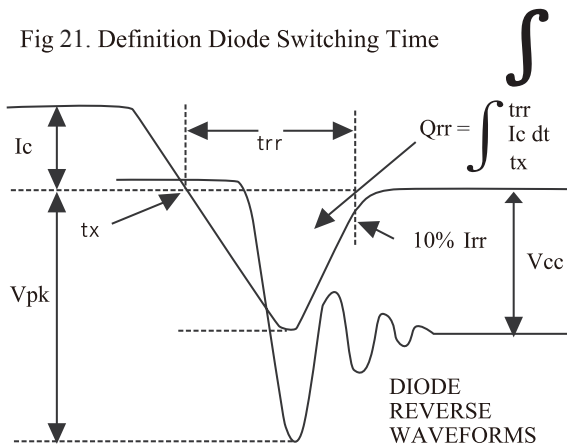

Fig 21. Definition Diode Switching Time





## X-ON Electronics

Largest Supplier of Electrical and Electronic Components

*Click to view similar products for [IGBT Transistors](#) category:*

*Click to view products by [KEC](#) manufacturer:*

Other Similar products are found below :

[IRG4PC30W](#) [APT20GT60BRDQ1G](#) [STGWA25H120DF2](#) [APT30GS60BRDQ2G](#) [GT50JR22\(STA1ES\)](#) [TIG058E8-TL-H](#) [IDW40E65D2](#)  
[APT40GR120B2SCD10](#) [NGTB75N65FL2WAG](#) [NTE3320](#) [STGW80H65DFB-4](#) [IKFW50N65EH5XKSA1](#) [IMBG120R090M1HXTMA1](#)  
[GT30N135SRA,S1E](#) [IGW30N60TP](#) [IGW40N60TP](#) [IGW50N60TP](#) [IHW30N65R5](#) [IKFW40N60DH3E](#) [IKP15N65H5](#) [IKQ100N60T](#)  
[IKQ120N60T](#) [IKW75N60H3](#) [IKZ50N65NH5](#) [IKZ75N65NH5](#) [FGD3040G2-F085C](#) [FGH4L50T65SQD](#) [FGHL40T65MQDT](#)  
[FGHL50T65MQD](#) [FGHL50T65MQDTL4](#) [FGHL75T65LQDT](#) [FGHL75T65MQD](#) [FGHL75T65MQDT](#) [FGHL75T65MQDTL4](#)  
[FGY75T120SWD](#) [EL3120S1\(TA\)\(SAS\)-V](#) [CRG40T60AK3SD](#) [CRG15T120BNR3S](#) [KGF75N65KDF-U/H](#) [MBQ40T120FESTH](#)  
[AOB10B65M1](#) [CRG15T60A83L](#) [CRG40T120BK3SD](#) [CRG40T65AN5H](#) [RGTH60TS65GC11](#) [FGH60N60SMD\\_F085](#) [FGH75T65UPD](#)  
[FGY75N60SMD](#) [NGB8206ANSL3G](#) [IKW20N60H3FKSA1](#)