

VOLTAGE DETECTOR

Function of this IC is accurately resetting the system after detecting voltage at the time of switching power on and instantaneous power off in various CPU systems and other logic systems.

FEATURES

- Current Consumption is Low. $I_{CCL}=300\ \mu\text{A}$ Typ. $I_{CCH}=30\ \mu\text{A}$ Typ.
- Resetting Output Minimum Guarantee Voltage is Low 0.8V Typ.
- Hysteresis Voltage is Provided. 50mV Typ.
- Reset Signal Generation Starting Voltages :
 - KIA7019 1.9V Typ. KIA7033 3.3V Typ.
 - KIA7021 2.1V Typ. KIA7034 3.4V Typ.
 - KIA7023 2.3V Typ. KIA7035 3.5V Typ.
 - KIA7025 2.5V Typ. KIA7036 3.6V Typ.
 - KIA7027 2.7V Typ. KIA7039 3.9V Typ.
 - KIA7029 2.9V Typ. KIA7042 4.2V Typ.
 - KIA7031 3.1V Typ. KIA7045 4.5V Typ.
 - KIA7032 3.2V Typ.
- Taping Type is also Available.
- Qualified to AEC-Q100.

APPLICATIONS

- (1) As Control Circuit of Battery-Backed Memory.
- (2) As Measure Against Erroneous Operations at Power ON-OFF.
- (3) As Measure Against System Runaway at Instantaneous Break of Power Supply etc.
- (4) As Resetting Function for the CPU-Mounted Equipment, such as Personal Computers, Printers, VTRs and so forth.

EQUIVALENT CIRCUIT

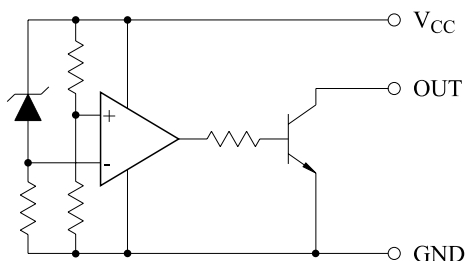

Marking

Type No.	Marking	Type No.	Marking	Type No.	Marking
KIA7019AF/AT	6A	KIA7029AF/AT	6F	KIA7035AF/AT	6L
KIA7021AF/AT	6B	KIA7031AF/AT	6G	KIA7036AF/AT	6M
KIA7023AF/AT	6C	KIA7032AF/AT	6H	KIA7039AF/AT	6N
KIA7025AF/AT	6D	KIA7033AF/AT	6J	KIA7042AF/AT	6P
KIA7027AF/AT	6E	KIA7034AF/AT	6K	KIA7045AF/AT	6R

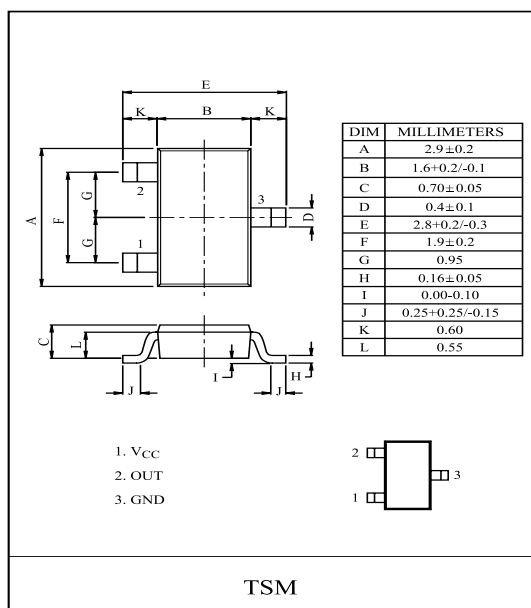
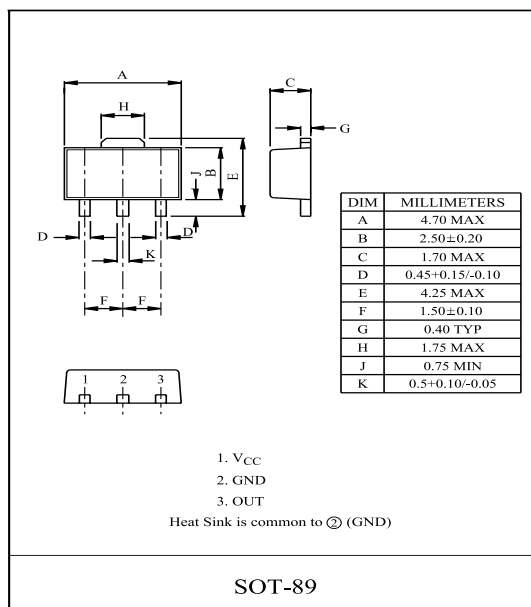
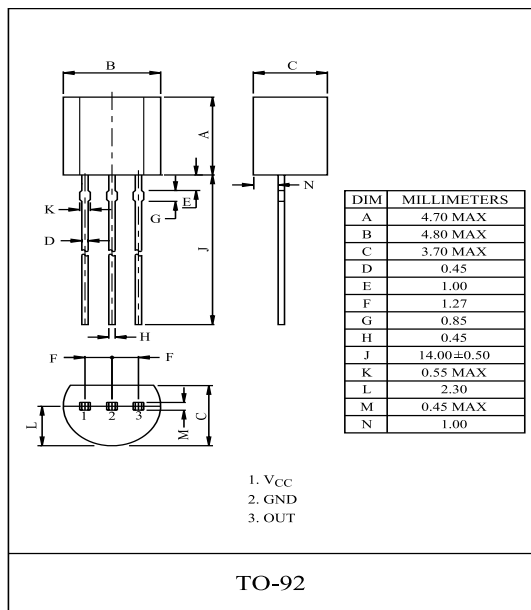

KIA7019AP/AF/AT~KIA7045AP/AF/AT

MAXIMUM RATINGS (Ta=25)

CHARACTERISTIC		SYMBOL	RATING	UNIT
Supply Voltage		V _{CC}	-0.3 +15.0	V
Power Dissipation (Package Limitation)	KIA7019AP 45AP	P _D	400	mW
	KIA7019AF 45AF		500	
	KIA7019AT 45AT		350	
Operating Temperature		T _{opr}	-30 +85	
Storage Temperature		T _{stg}	-55 +150	

ELECTRICAL CHARACTERISTICS (V_{CC}=5V, V_{EE}=GND, Ta=25)

CHARACTERISTIC	SYMBOL	TEST CIRCUIT	TEST CONDITION	MIN.	TYP.	MAX.	UNIT	
Detecting Voltage	V _S	1	R _L =200 V _{OL} 0.4V	KIA7019	1.75	1.9	2.05	V
				KIA7021	1.95	2.1	2.25	
				KIA7023	2.15	2.3	2.45	
				KIA7025	2.35	2.5	2.65	
				KIA7027	2.55	2.7	2.85	
				KIA7029	2.75	2.9	3.05	
				KIA7031	2.95	3.1	3.25	
				KIA7032	3.05	3.2	3.35	
				KIA7033	3.15	3.3	3.45	
				KIA7034	3.25	3.4	3.55	
				KIA7035	3.35	3.5	3.65	
				KIA7036	3.45	3.6	3.75	
				KIA7039	3.75	3.9	4.05	
				KIA7042	4.05	4.2	4.35	
				KIA7045	4.35	4.5	4.65	
Low-Level Output Voltage	V _{OL}	1	R _L =200	-	-	0.4	V	
Output Leakage Current	I _{OH}	1	V _{CC} =15V	-	-	0.1	μA	
Hysteresis Voltage	V _S	1	R _L =200	30	50	100	mV	
Detecting Voltage Temperature Coefficient	V _S / T	1	R _L =200	-	± 0.01	-	%/	
Circuit Current at on Time	I _{ccL}	1	V _{CC} =V _{Smin} .-0.05V	-	300	500	μA	
Circuit Current at off Time	I _{ccH}	1	V _{CC} =5.25V	-	30	50	μA	
Threshold Operating Voltage	V _{opr}	1	R _L =200 , V _{OL} 0.4V	-	0.8	-	V	
"L" Transmission Delay Time	tpHL	2	R _L =1.0k , C _L =100pF	-	10	-	μs	
"H" Transmission Delay Time	tpLH	2	R _L =1.0k , C _L =100pF	-	15	-	μs	
Output Current at on Time I	IoL I	1	V _{CC} =V _{Smin} .-0.05V, Tc=25	20	-	-	mA	
Output Current at on Time II	IoL II	1	V _{CC} =V _{Smin} .-0.05V, Tc=-30 +75	16	-	-	mA	

KIA7019AP/AF/AT~KIA7045AP/AF/AT

TEST CIRCUIT 1.

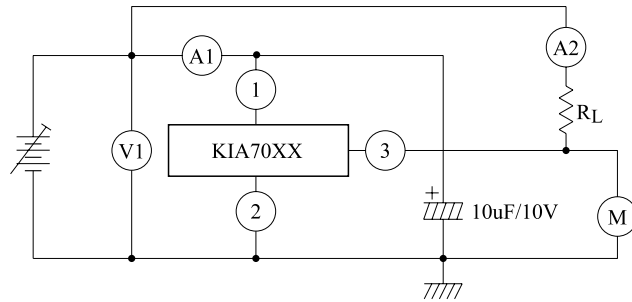

TEST CIRCUIT 2.

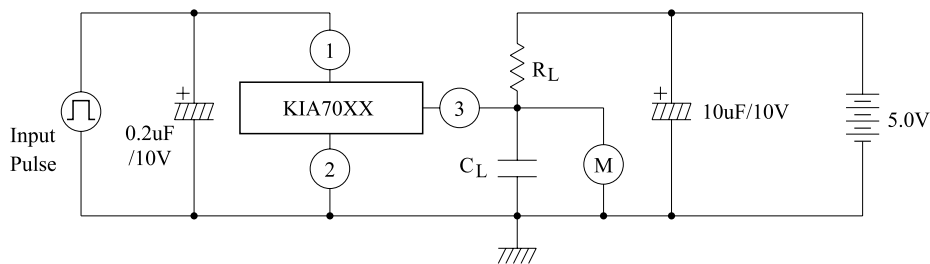

APPLICATION CIRCUIT

(1) BATTERY LOW INDICATOR

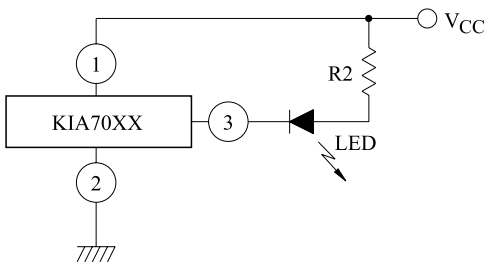

(2) CPU RESETING

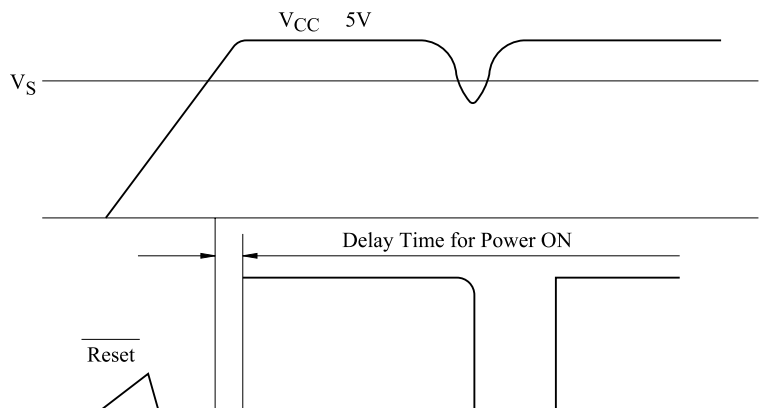
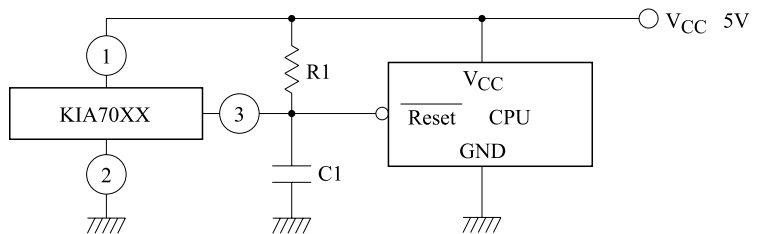

(Note)

(1) Connecting of LED and R2 obtains a voltage drop indicator.

(2) Connecting of C1 and selection of time constant with C1 and R1 set the power on delay time.

KIA7019AP/AF/AT~KIA7045AP/AF/AT

PRECAUTION FOR USE

Lead-Free Soldering Condition.

Elements mounting styles of electronic devices are gaining in further diversification over recent years, and needs for components are all the more expanding in varieties. Especially, surface mounting is steadily penetrating into industrial segments as a world-wide popular technical trend. Although exposure to high temperature is inevitable during soldering we recommend limiting the soldering temperature to low levels as shown in figure for the sake of retaining inherent excellent reliability.

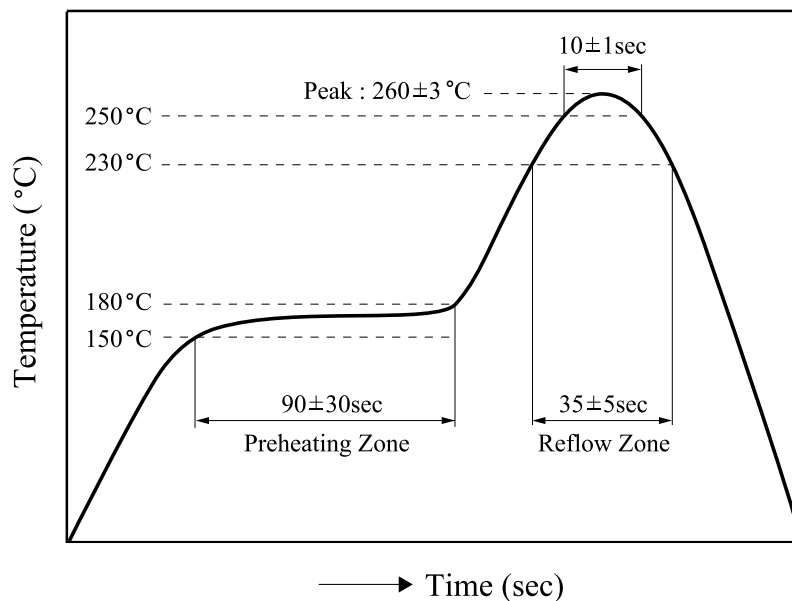

[Lead-Free Soldering Temperature Profile]

1. When employing solder reflow method

1) Soldering Condition

Standard Condition : 250 (Temperature), 10 ± 1sec. (Time)

Peak Condition : 260 ± 3

2) Recommend temperature profile

3) Precautions on heating method

When resin is kept exposed to high temperature for a long time, device reliability may be marred.

Therefore, it is essential to complete soldering in the shortest time possible to prevent temperature of resin from rising.

2. When employing halogen lamps or infrared-ray heaters

When halogen lamps or infrared-ray heaters are used, avoid direct irradiation onto resin surfaces; such devices cause extensive localized temperature rise.

Please keep a reflow solder operating when Surface Mount Package s Soldering.

X-ON Electronics

Largest Supplier of Electrical and Electronic Components

Click to view similar products for [Power Management Specialised - PMIC category](#):

Click to view products by [KEC manufacturer](#):

Other Similar products are found below :

[LV5686PVC-XH](#) [FAN7710VN](#) [NCP391FCALT2G](#) [SLG7NT4081VTR](#) [SLG7NT4192VTR](#) [AP4313UKTR-G1](#) [MB39C831QN-G-EFE2](#)
[LV56841PVD-XH](#) [S6AE102A0DGN1B200](#) [MMPF0100FDAEP](#) [S6AE101A0DGNAB200](#) [NCP6924CFCHT1G](#) [AP4306BUKTR-G1](#)
[IR35217MTRPBF](#) [MIC5164YMM](#) [PT8A3252WE](#) [NCP6914AFCAT1G](#) [NCP392CSFCCT1G](#) [TEA1998TS/1H](#) [PT8A3284WE](#)
[LTC3643EUDD#PBF](#) [TEA2095T/1/S30J](#) [MCP16502TAD-E/S8B](#) [PCA9420BSAZ](#) [MC33PF8100FJES](#) [ISL91211AIKZT7AR5874](#)
[ISL91211BIKZT7AR5878](#) [ISL91212AIIZ-TR5770](#) [ISL91212BIIZ-TR5775](#) [MC34VR5100A1EP](#) [AX-3003D-3](#) [AX-3005D-3](#) [TP-1305](#) [TP-](#)
[2305](#) [TP-30102](#) [TP-4503N](#) [MIC5167YML-TR](#) [MPS-3003L-3](#) [MPS-3005D](#) [NCP392ARFCCT1G](#) [SPD-3606](#) [STLUX383A](#) [TP-60052](#)
[A8603KESTR-R](#) [ADN8834ACBZ-R7](#) [LM81BIMTX-3/NOPB](#) [LM81CIMT-3/NOPB](#) [LP2996AMRX/NOPB](#) [LP2996AMRENOPB](#) [LV5696P-](#)
[E](#)