

1A THREE TERMINAL NEGATIVE VOLTAGE REGULATORS -5V, -6V, -7V, -8V, -9V, -10V, -12V, -15V, -18V, -20V, -24V.

FEATURES

- Suitable for C-MOS, TTL, and the other digital IC power supply.
- Internal thermal overload protecting.
- Internal short circuit current limiting.
- Output current in excess of 1.0A.
- Suffix U : Qualified to AEC-Q100.

ex) KIA79**F-RTF/PU

LINE-UP

ITEM	OUTPUT VOLTAGE (Typ.)	UNIT
KIA7905F/PI	-5	F : DPAK PI : TO-220IS
KIA7906F/PI	-6	
KIA7907F/PI	-7	
KIA7908F/PI	-8	
KIA7909F/PI	-9	
KIA7910F/PI	-10	
KIA7912F/PI	-12	
KIA7915F/PI	-15	
KIA7918F/PI	-18	
KIA7920F/PI	-20	
KIA7924F/PI	-24	

MAXIMUM RATINGS (Ta=25)

CHARACTERISTIC		SYMBOL	RATING	UNIT
Input Voltage	KIA7905	V _{IN}	-35	V
	KIA7915			
	KIA7918		-40	
	KIA7924			
Power Dissipation-1 (No Heatsink)	F	P _{D1}	1.3	W
	PI		2.0	
Power Dissipation-2 (Infinite Heatsink)	F	P _{D2}	12.0	W
	PI		20.8	
Operating Junction Temperature		T _j	-40 150	
Operating Temperature		T _{opr}	-40 85	
Storage Temperature		T _{stg}	-55 150	

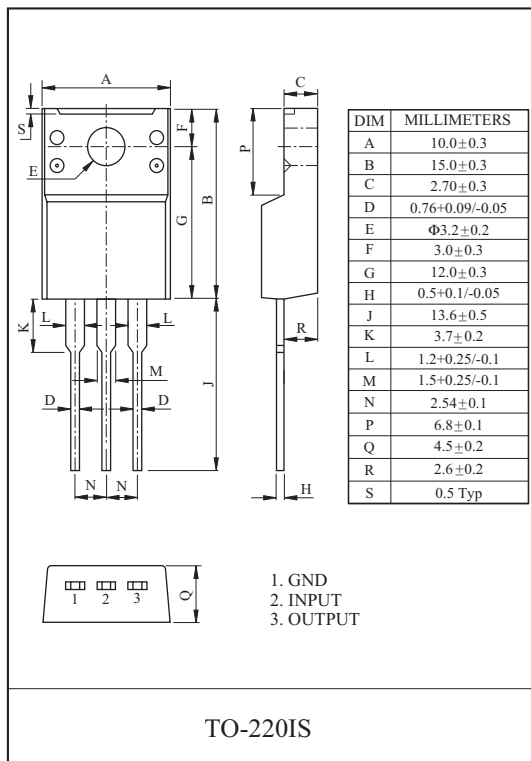
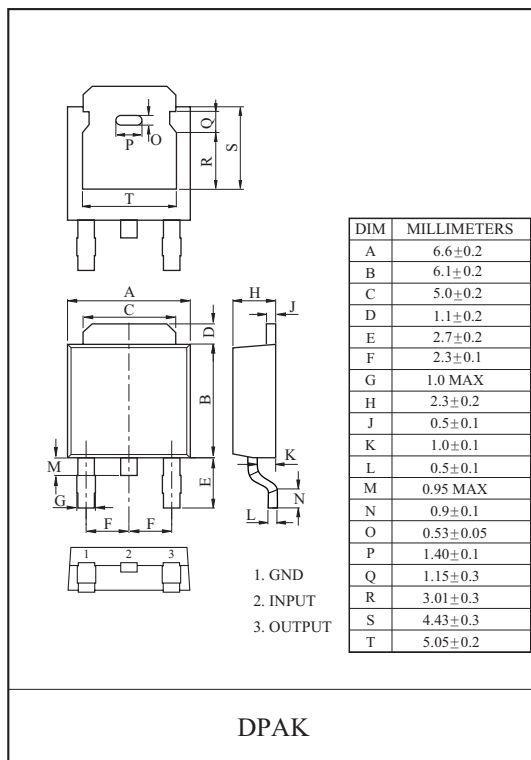

KIA7905F/PI~KIA7924F/PI

EQUIVALENT CIRCUIT

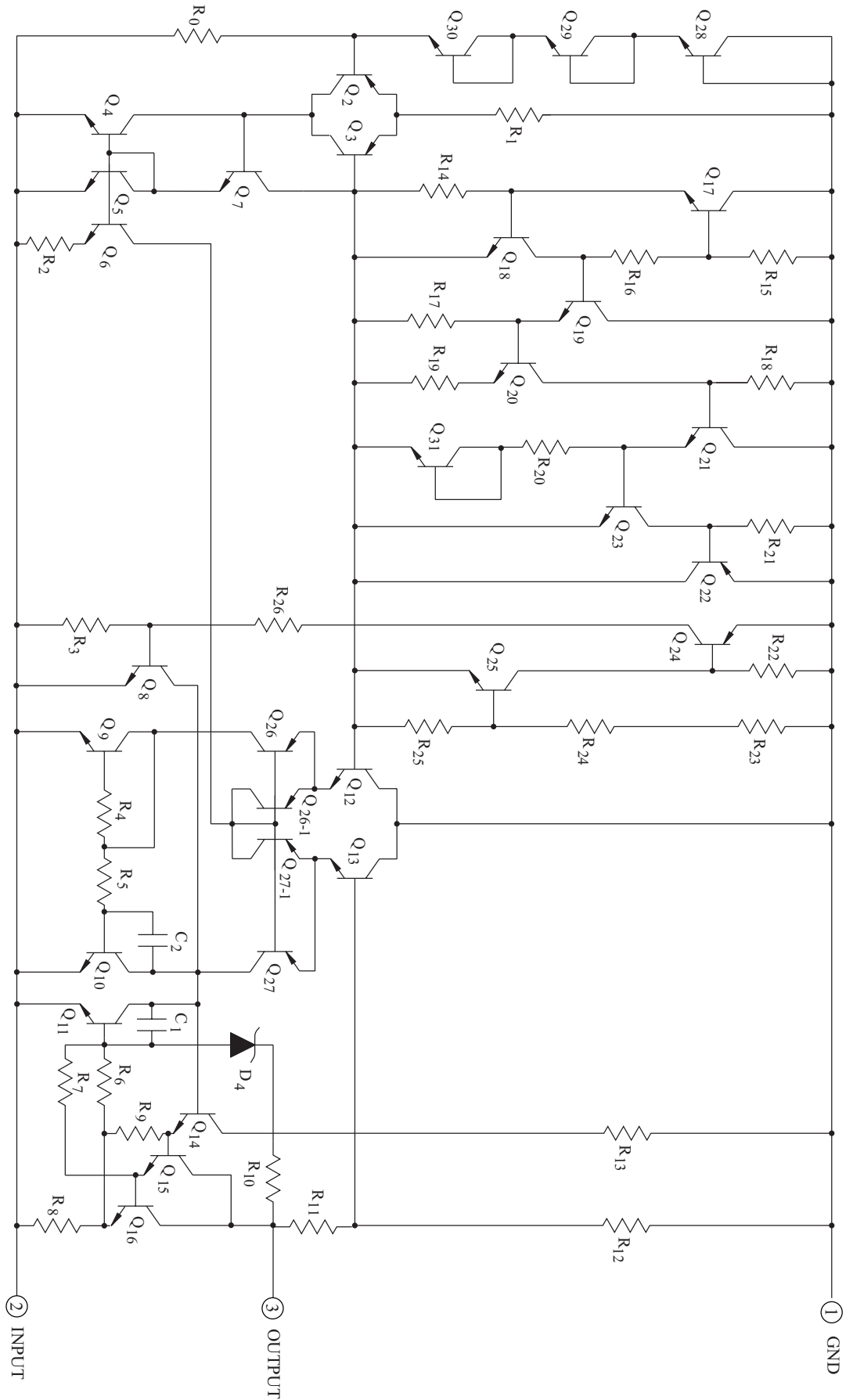

KIA7905F/PI~KIA7924F/PI

ELECTRICAL CHARACTERISTICS

KIA7905F/PI

(Unless otherwise specified, $V_{IN}=-10V$, $I_{OUT}=500mA$, $\theta_{Tj} = 125$, $C_{IN}=2.2\mu F$, $C_{OUT}=1\mu F$)

CHARACTERISTIC	SYMBOL	TEST CIRCUIT	TEST CONDITION	MIN.	TYP.	MAX.	UNIT	
Output Voltage	V_{OUT}	Fig.1	$T_j=25$	-5.2	-5.0	-4.8	V	
Input Regulation	Reg line	Fig.1	$T_j=25$	-12V V_{IN} -8V	-	5	50	mV
				-25V V_{IN} -7V	-	10	100	
Load Regulation	Reg load	Fig.1	$T_j=25$	5mA I_{OUT} 1.5A	-	10	100	mV
				250mA I_{OUT} 750mA	-	3	50	
Output Voltage	V_{OUT}	Fig.1	-20V V_{IN} -7V 5mA I_{OUT} 1.0A	-5.25	-5.0	-4.75	V	
Quiescent Current	I_B	Fig.1	$T_j=25$	-	3	6	mA	
Quiescent Current Change	I_{BI}	Fig.1	$T_j=25$	-25V V_{IN} -8V	-	0.1	1.3	mA
	I_{BO}			5mA I_{OUT} 1.0A	-	0.05	0.5	
Output Noise Voltage	V_{NO}	Fig.2	$T_a=25$, 10Hz f 100kHz	-	100	-	μV_{rms}	
Ripple Rejection Ratio	RR	Fig.3	$f=120Hz$, $I_{OUT}=20mA$,	54	60	-	dB	
Short Circuit Current Limit	I_{SC}	Fig.1	$T_j=25$	-	1.9	-	A	
Average Temperature Coefficient of Output Voltage	T_{CVO}	Fig.1	$I_{OUT}=5.0mA$	-	-0.4	-	mV/	
Dropout Voltage	V_D	Fig.1	$T_j=25$, $I_{OUT}=1A$	-	2.0	-	V	

KIA7905F/PI~KIA7924F/PI

ELECTRICAL CHARACTERISTICS

KIA7906F/PI

(Unless otherwise specified, $V_{IN}=-11V$, $I_{OUT}=500mA$, $0 < T_j < 125$, $C_{IN}=2.2 \mu F$, $C_{OUT}=1 \mu F$)

CHARACTERISTIC		SYMBOL	TEST CIRCUIT	TEST CONDITION	MIN.	TYP.	MAX.	UNIT	
Output Voltage		V_{OUT}	Fig.1	$T_j=25$	-6.25	-6.0	-5.75	V	
Input Regulation		Reg line	Fig.1	$T_j=25$	-13V V_{IN} -9V	-	5	60	mV
					-25V V_{IN} -8V	-	10	120	
Load Regulation		Reg load	Fig.1	$T_j=25$	5mA I_{OUT} 1.5A	-	10	120	mV
					250mA I_{OUT} 750mA	-	3	60	
Output Voltage		V_{OUT}	Fig.1	-21V V_{IN} -9V 5mA I_{OUT} 1.0A	-6.3	-6.0	-5.7	V	
Quiescent Current		I_B	Fig.1	$T_j=25$	-	3	6	mA	
Quiescent Current Change		Line	Fig.1	$T_j=25$	-25V V_{IN} -9V	-	-	1.3	mA
		Load			5mA I_{OUT} 1.0A	-	-	0.5	
Output Noise Voltage		V_{NO}	Fig.2	$T_a=25$, 10Hz f 100kHz	-	130	-	μV_{rms}	
Ripple Rejection Ratio		RR	Fig.3	$f=120Hz$, $I_{OUT}=20mA$,	54	60	-	dB	
Short Circuit Current Limit		I_{SC}	Fig.1	$T_j=25$	-	1.9	-	A	
Average Temperature Coefficient of Output Voltage		T_{CVO}	Fig.1	$I_{OUT}=5mA$	-	-0.5	-	mV/	
Dropout Voltage		V_D	Fig.1	$T_j=25$, $I_{OUT}=1A$	-	2.0	-	V	

KIA7905F/PI~KIA7924F/PI

ELECTRICAL CHARACTERISTICS

KIA7907F/PI

(Unless otherwise specified, $V_{IN}=-12V$, $I_{OUT}=500mA$, $0 < T_j < 125$, $C_{IN}=2.2 \mu F$, $C_{OUT}=1 \mu F$)

CHARACTERISTIC		SYMBOL	TEST CIRCUIT	TEST CONDITION	MIN.	TYP.	MAX.	UNIT	
Output Voltage		V_{OUT}	Fig.1	$T_j=25$	-7.28	-7.0	-6.72	V	
Input Regulation		Reg line	Fig.1	$T_j=25$	-15V V_{IN} -10V	-	10	70	mV
					-25V V_{IN} -9V	-	45	140	
Load Regulation		Reg load	Fig.1	$T_j=25$	5mA I_{OUT} 1.5A	-	20	140	mV
					250mA I_{OUT} 750mA	-	7	70	
Output Voltage		V_{OUT}	Fig.1	-22V V_{IN} -9V 5mA I_{OUT} 1.0A	-7.35	-	-6.65	V	
Quiescent Current		I_B	Fig.1	$T_j=25$	-	4.3	8.0	mA	
Quiescent Current Change		Line	Fig.1	-25V V_{IN} -9V	-	-	1.0	mA	
		Load		5mA I_{OUT} 1.0A	-	-	0.5		
Output Noise Voltage		V_{NO}	Fig.2	$T_a=25$, 10Hz f 100kHz	-	49	-	μV_{rms}	
Ripple Rejection Ratio		RR	Fig.3	$f=120Hz$, $I_{OUT}=20mA$,	60	67	-	dB	
Short Circuit Current Limit		I_{SC}	Fig.1	$T_j=25$	-	1.9	-	A	
Average Temperature Coefficient of Output Voltage		T_{CVO}	Fig.1	$I_{OUT}=5mA$	-	0.9	-	mV/	
Dropout Voltage		V_D	Fig.1	$T_j=25$, $I_{OUT}=1A$	-	2.0	-	V	

KIA7905F/PI~KIA7924F/PI

ELECTRICAL CHARACTERISTICS

KIA7908F/PI

(Unless otherwise specified, $V_{IN}=-14V$, $I_{OUT}=500mA$, $\theta_{Tj} 125$, $C_{IN}=2.2 \mu F$, $C_{OUT}=1 \mu F$)

CHARACTERISTIC		SYMBOL	TEST CIRCUIT	TEST CONDITION	MIN.	TYP.	MAX.	UNIT	
Output Voltage		V_{OUT}	Fig.1	$T_j=25$	-8.3	-8.0	-7.7	V	
Input Regulation		Reg line	Fig.1	$T_j=25$	-17V V_{IN} -11V	-	5	80	mV
					-25V V_{IN} -10.5V	-	10	100	
Load Regulation		Reg load	Fig.1	$T_j=25$	5mA I_{OUT} 1.5A	-	12	160	mV
					250mA I_{OUT} 750mA	-	4	80	
Output Voltage		V_{OUT}	Fig.1	-23V V_{IN} -11.5V 5mA I_{OUT} 1.0A	-8.4	-8.0	-7.6	V	
Quiescent Current		I_B	Fig.1	$T_j=25$	-	3	6	mA	
Quiescent Current Change		Line	Fig.1	$T_j=25$	-25V V_{IN} -11.5V	-	0.1	1.0	mA
		Load			5mA I_{OUT} 1.0A	-	0.05	0.5	
Output Noise Voltage		V_{NO}	Fig.2	$T_a=25$, 10Hz f 100kHz	-	175	-	μV_{rms}	
Ripple Rejection Ratio		RR	Fig.3	$f=120Hz$, $I_{OUT}=20mA$,	54	60	-	dB	
Short Circuit Current Limit		I_{SC}	Fig.1	$T_j=25$	-	1.9	-	A	
Average Temperature Coefficient of Output Voltage		T_{CVO}	Fig.1	$I_{OUT}=5mA$	-	-0.6	-	mV/	
Dropout Voltage		V_D	Fig.1	$T_j=25$, $I_{OUT}=1A$	-	2.0	-	V	

KIA7905F/PI~KIA7924F/PI

ELECTRICAL CHARACTERISTICS

KIA7909F/PI

(Unless otherwise specified, $V_{IN}=-15V$, $I_{OUT}=500mA$, θ T_j 125 , $C_{IN}=2.2 \mu F$, $C_{OUT}=1 \mu F$)

CHARACTERISTIC		SYMBOL	TEST CIRCUIT	TEST CONDITION	MIN.	TYP.	MAX.	UNIT	
Output Voltage		V_{OUT}	Fig.1	$T_j=25$	-9.3	-9.0	-8.7	V	
Input Regulation		Reg line	Fig.1	$T_j=25$	-19V V_{IN} -13V	-	5	90	mV
					-26V V_{IN} -11.5V	-	10	100	
Load Regulation		Reg load	Fig.1	$T_j=25$	5mA I_{OUT} 1.5A	-	10	150	mV
					250mA I_{OUT} 750mA	-	5	120	
Output Voltage		V_{OUT}	Fig.1	-24V V_{IN} -11.5V 5mA I_{OUT} 1.0A	-9.4	-9.0	-8.6	V	
Quiescent Current		I_B	Fig.1	$T_j=25$	-	3	6	mA	
Quiescent Current Change		Line	Fig.1	$T_j=25$	-26.5V V_{IN} -13V	-	0.1	1.0	mA
		Load			5mA I_{OUT} 1.0A	-	0.05	0.5	
Output Noise Voltage		V_{NO}	Fig.2	$T_a=25$, 10Hz f 100kHz	-	180	-	μV_{rms}	
Ripple Rejection Ratio		RR	Fig.3	$f=120Hz$, $I_{OUT}=20mA$,	54	60	-	dB	
Short Circuit Current Limit		I_{SC}	Fig.1	$T_j=25$	-	1.9	-	A	
Average Temperature Coefficient of Output Voltage		T_{CVO}	Fig.1	$I_{OUT}=5mA$	-	-0.7	-	mV/	
Dropout Voltage		V_D	Fig.1	$T_j=25$, $I_{OUT}=1A$	-	2.0	-	V	

KIA7905F/PI~KIA7924F/PI

ELECTRICAL CHARACTERISTICS

KIA7910F/PI

(Unless otherwise specified, $V_{IN}=-16V$, $I_{OUT}=500mA$, θ T_j 125 , $C_{IN}=2.2 \mu F$, $C_{OUT}=1 \mu F$)

CHARACTERISTIC		SYMBOL	TEST CIRCUIT	TEST CONDITION	MIN.	TYP.	MAX.	UNIT
Output Voltage		V_{OUT}	Fig.1	$T_j=25$	-10.4	-10	-9.6	V
Input Regulation	Reg line	Fig.1	$T_j=25$	-20V V_{IN} -14V	-	5	100	mV
				-27V V_{IN} -12.5V	-	10	110	
Load Regulation	Reg load	Fig.1	$T_j=25$	5mA I_{OUT} 1.5A	-	10	180	mV
				250mA I_{OUT} 750mA	-	6	120	
Output Voltage		V_{OUT}	Fig.1	-25V V_{IN} -12.5V 5mA I_{OUT} 1.0A	-10.5	-10	-9.5	V
Quiescent Current		I_B	Fig.1	$T_j=25$	-	3	6	mA
Quiescent Current Change	Line	I_{BI}	Fig.1	-27.5V V_{IN} -14V	-	0.1	1.0	mA
	Load	I_{BO}		5mA I_{OUT} 1.0A	-	0.05	0.5	
Output Noise Voltage		V_{NO}	Fig.2	$T_a=25$, 10Hz f 100kHz	-	190	-	μV_{rms}
Ripple Rejection Ratio		RR	Fig.3	$f=120Hz$, $I_{OUT}=20mA$	54	60	-	dB
Short Circuit Current Limit		I_{SC}	Fig.1	$T_j=25$	-	1.9	-	A
Average Temperature Coefficient of Output Voltage		T_{CVO}	Fig.1	$I_{OUT}=5mA$	-	-0.7	-	mV/
Dropout Voltage		V_D	Fig.1	$T_j=25$, $I_{OUT}=1A$	-	2.0	-	V

KIA7905F/PI~KIA7924F/PI

ELECTRICAL CHARACTERISTICS

KIA7912F/PI

(Unless otherwise specified, $V_{IN}=-18V$, $I_{OUT}=500mA$, θ T_j 125 , $C_{IN}=2.2 \mu F$, $C_{OUT}=1 \mu F$)

CHARACTERISTIC		SYMBOL	TEST CIRCUIT	TEST CONDITION	MIN.	TYP.	MAX.	UNIT	
Output Voltage		V_{OUT}	Fig.1	$T_j=25$	-12.5	-12	-11.5	V	
Input Regulation		Reg line	Fig.1	$T_j=25$	-22V V_{IN} -16V	-	6	120	mV
					-30V V_{IN} -14.5V	-	12	240	
Load Regulation		Reg load	Fig.1	$T_j=25$	5mA I_{OUT} 1.5A	-	12	240	mV
					250mA I_{OUT} 750mA	-	4	120	
Output Voltage		V_{OUT}	Fig.1	-27V V_{IN} -15.5V 5mA I_{OUT} 1.0A	-12.6	-12	-11.4	V	
Quiescent Current		I_B	Fig.1	$T_j=25$	-	3	6	mA	
Quiescent Current Change		Line	Fig.1	$T_j=25$	-30V V_{IN} -15V	-	0.1	1.0	mA
		Load			5mA I_{OUT} 1.0A	-	0.05	0.5	
Output Noise Voltage		V_{NO}	Fig.2	$T_a=25$, 10Hz f 100kHz	-	200	-	μV_{rms}	
Ripple Rejection Ratio		RR	Fig.3	$f=120Hz$, $I_{OUT}=20mA$,	54	60	-	dB	
Short Circuit Current Limit		I_{SC}	Fig.1	$T_j=25$	-	1.9	-	A	
Average Temperature Coefficient of Output Voltage		T_{CVO}	Fig.1	$I_{OUT}=5mA$	-	-0.8	-	mV/	
Dropout Voltage		V_D	Fig.1	$T_j=25$, $I_{OUT}=1A$	-	2.0	-	V	

KIA7905F/PI~KIA7924F/PI

ELECTRICAL CHARACTERISTICS

KIA7915F/PI

(Unless otherwise specified, $V_{IN}=-23V$, $I_{OUT}=500mA$, $\theta_{Tj} = 125$, $C_{IN}=2.2 \mu F$, $C_{OUT}=1 \mu F$)

CHARACTERISTIC		SYMBOL	TEST CIRCUIT	TEST CONDITION	MIN.	TYP.	MAX.	UNIT	
Output Voltage		V_{OUT}	Fig.1	$T_j=25$	-15.6	-15	-14.4	V	
Input Regulation		Reg line	Fig.1	$T_j=25$	-26V V_{IN} -20V	-	6	150	mV
					-30V V_{IN} -17.5V	-	12	300	
Load Regulation		Reg load	Fig.1	$T_j=25$	5mA I_{OUT} 1.5A	-	12	300	mV
					250mA I_{OUT} 750mA	-	4	150	
Output Voltage		V_{OUT}	Fig.1	-30V V_{IN} -18V 5mA I_{OUT} 1.0A	-15.75	-15	-14.25	V	
Quiescent Current		I_B	Fig.1	$T_j=25$	-	3	6	mA	
Quiescent Current Change		Line	Fig.1	$T_j=25$	-30V V_{IN} -17.5V	-	0.1	1.0	mA
		Load			5mA I_{OUT} 1.0A	-	0.05	0.5	
Output Noise Voltage		V_{NO}	Fig.2	$T_a=25$, 10Hz f 100kHz	-	250	-	μV_{rms}	
Ripple Rejection Ratio		RR	Fig.3	$f=120Hz$, $I_{OUT}=20mA$,	54	60	-	dB	
Short Circuit Current Limit		I_{SC}	Fig.1	$T_j=25$	-	1.9	-	A	
Average Temperature Coefficient of Output Voltage		T_{CVO}	Fig.1	$I_{OUT}=5mA$	-	-0.9	-	mV/	
Dropout Voltage		V_D	Fig.1	$T_j=25$, $I_{OUT}=1A$	-	2.0	-	V	

KIA7905F/PI~KIA7924F/PI

ELECTRICAL CHARACTERISTICS

KIA7918F/PI

(Unless otherwise specified, $V_{IN}=-27V$, $I_{OUT}=500mA$, θ T_j 125 , $C_{IN}=2.2 \mu F$, $C_{OUT}=1 \mu F$)

CHARACTERISTIC		SYMBOL	TEST CIRCUIT	TEST CONDITION	MIN.	TYP.	MAX.	UNIT	
Output Voltage		V_{OUT}	Fig.1	$T_j=25$	-18.7	-18	-17.3	V	
Input Regulation		Reg line	Fig.1	$T_j=25$	-30V V_{IN} -24V	-	8	180	mV
					-33V V_{IN} -21V	-	15	360	
Load Regulation		Reg load	Fig.1	$T_j=25$	5mA I_{OUT} 1.5A	-	15	360	mV
					250mA I_{OUT} 750mA	-	5	180	
Output Voltage		V_{OUT}	Fig.1	-33V V_{IN} -22.5V 5mA I_{OUT} 1.0A	-18.85	-18	-17.15	V	
Quiescent Current		I_B	Fig.1	$T_j=25$	-	3	6	mA	
Quiescent Current Change		Line	Fig.1	$T_j=25$	-33V V_{IN} -22V	-	-	1.0	mA
		Load			5mA I_{OUT} 1.0A	-	-	0.5	
Output Noise Voltage		V_{NO}	Fig.2	$T_a=25$, 10Hz f 100kHz	-	300	-	μV_{rms}	
Ripple Rejection Ratio		RR	Fig.3	$f=120Hz$, $I_{OUT}=20mA$,	54	60	-	dB	
Short Circuit Current Limit		I_{SC}	Fig.1	$T_j=25$	-	1.9	-	A	
Average Temperature Coefficient of Output Voltage		T_{CVO}	Fig.1	$I_{OUT}=5mA$	-	-1.0	-	mV/	
Dropout Voltage		V_D	Fig.1	$T_j=25$, $I_{OUT}=1A$	-	2.0	-	V	

KIA7905F/PI~KIA7924F/PI

ELECTRICAL CHARACTERISTICS

KIA7920F/PI

(Unless otherwise specified, $V_{IN}=-30V$, $I_{OUT}=500mA$, $0 < T_j < 125$, $C_{IN}=2.2 \mu F$, $C_{OUT}=1 \mu F$)

CHARACTERISTIC		SYMBOL	TEST CIRCUIT	TEST CONDITION	MIN.	TYP.	MAX.	UNIT	
Output Voltage		V_{OUT}	Fig.1	$T_j=25$	-20.8	-20	-19.2	V	
Input Regulation		Reg line	Fig.1	$T_j=25$	-32V V_{IN} -26V	-	10	180	mV
					-35V V_{IN} -24V	-	18	360	
Load Regulation		Reg load	Fig.1	$T_j=25$	5mA I_{OUT} 1.5A	-	18	360	mV
					250mA I_{OUT} 750mA	-	10	180	
Output Voltage		V_{OUT}	Fig.1	-35V V_{IN} -24 5mA I_{OUT} 1.0A	-21.0	-20	-19.0	V	
Quiescent Current		I_B	Fig.1	$T_j=25$	-	3	6	mA	
Quiescent Current Change		Line	Fig.1	-36.5V V_{IN} -25V 5mA I_{OUT} 1.0A	-	-	1.0	mA	
		Load							5mA I_{OUT} 1.0A
Output Noise Voltage		V_{NO}	Fig.2	$T_a=25$, 10Hz f 100kHz	-	350	-	μV_{rms}	
Ripple Rejection Ratio		RR	Fig.3	$f=120Hz$, $I_{OUT}=20mA$	54	60	-	dB	
Short Circuit Current Limit		I_{SC}	Fig.1	$T_j=25$	-	1.9	-	A	
Average Temperature Coefficient of Output Voltage		T_{CVO}	Fig.1	$I_{OUT}=5mA$	-	-1.0	-	mV/	
Dropout Voltage		V_D	Fig.1	$T_j=25$, $I_{OUT}=1A$	-	2.0	-	V	

KIA7905F/PI~KIA7924F/PI

ELECTRICAL CHARACTERISTICS

KIA7924F/PI

(Unless otherwise specified, $V_{IN}=-33V$, $I_{OUT}=500mA$, θ T_j 125 , $C_{IN}=0.33 \mu F$, $C_{OUT}=0.1 \mu F$)

CHARACTERISTIC		SYMBOL	TEST CIRCUIT	TEST CONDITION	MIN.	TYP.	MAX.	UNIT	
Output Voltage		V_{OUT}	Fig.1	$T_j=25$	-25	-24	-23	V	
Input Regulation		Reg line	Fig.1	$T_j=25$	-36V V_{IN} -30V	-	8	240	mV
					-38V V_{IN} -27V	-	15	480	
Load Regulation		Reg load	Fig.1	$T_j=25$	5mA I_{OUT} 1.5A	-	15	480	mV
					250mA I_{OUT} 750mA	-	5	240	
Output Voltage		V_{OUT}	Fig.1	-38V V_{IN} -27V 5mA I_{OUT} 1.0A	-25.2	-24	-22.5	V	
Quiescent Current		I_B	Fig.1	$T_j=25$	-	3	6	mA	
Quiescent Current Change		Line	Fig.1	$T_j=25$	-38V V_{IN} -27V	-	-	1.0	mA
		Load			5mA I_{OUT} 1.0A	-	-	0.5	
Output Noise Voltage		V_{NO}	Fig.2	$T_a=25$, 10Hz f 100kHz	-	400	-	μV_{rms}	
Ripple Rejection Ratio		RR	Fig.3	$f=120Hz$, $I_{OUT}=20mA$,	54	60	-	dB	
Short Circuit Current Limit		I_{SC}	Fig.1	$T_j=25$	-	1.9	-	A	
Average Temperature Coefficient of Output Voltage		T_{CVO}	Fig.1	$I_{OUT}=5mA$	-	-1.0	-	mV/	
Dropout Voltage		V_D	Fig.1	$T_a=25$, $I_{OUT}=1A$	-	2.0	-	V	

KIA7905F/PI~KIA7924F/PI

Fig.1 Standard Test Circuit

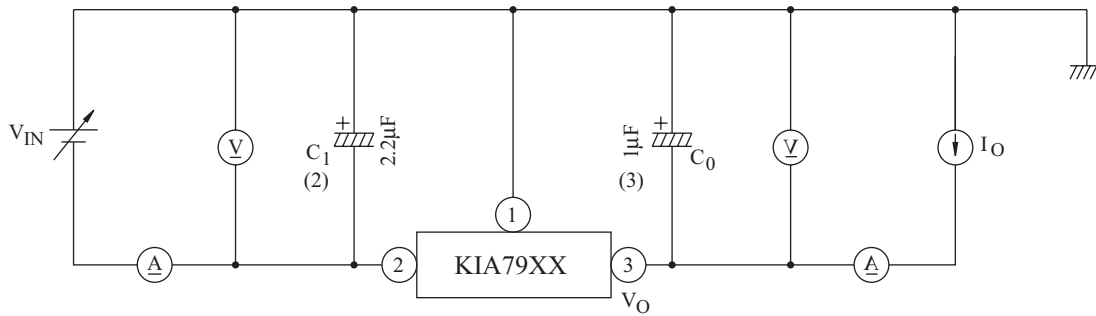

Notes : (1) To specify an output voltage, substitute voltage value for "XX"

(2) Required for stability. For value given, capacitor must be solid tantalum. If aluminum electrolytics are used, at least ten times value shown should be selected. C_1 is required if regulator is located an appreciable distance from power supply filter.

(3) To improve transient response. If large capacitors are used, a high current diode from input to output (1N4001 or similar) should be introduced to protect the device from momentary input short circuit.

Fig.2 V_{NO} Test Circuit

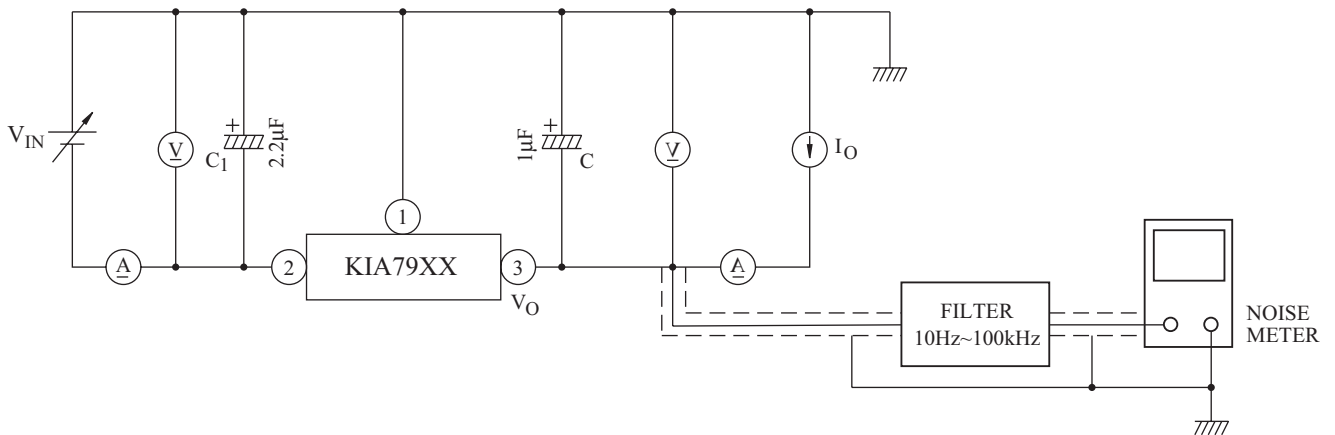
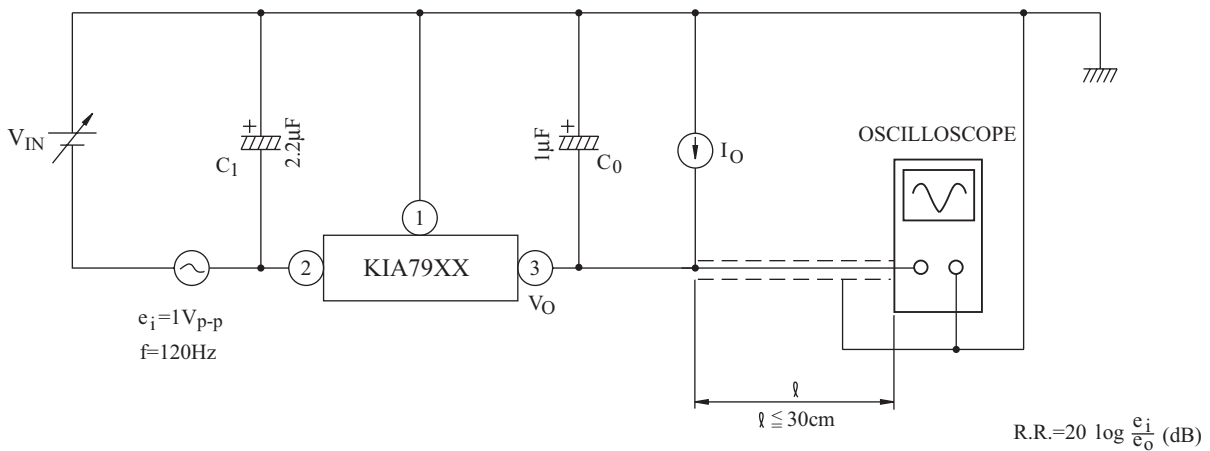

Fig.3 Ripple Rejection Test Circuit



KIA7905F/PI~KIA7924F/PI

Fig. 4

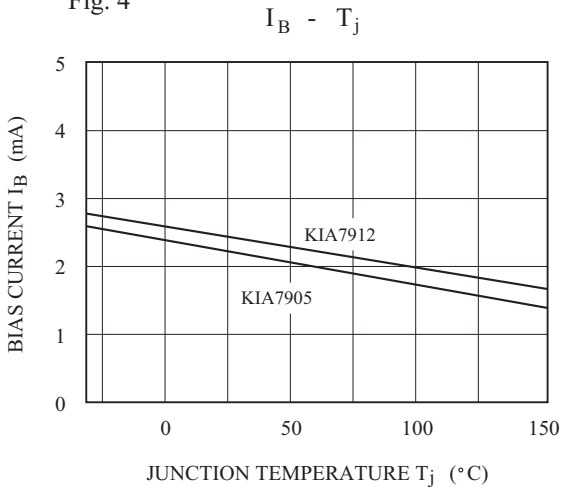

Fig. 5

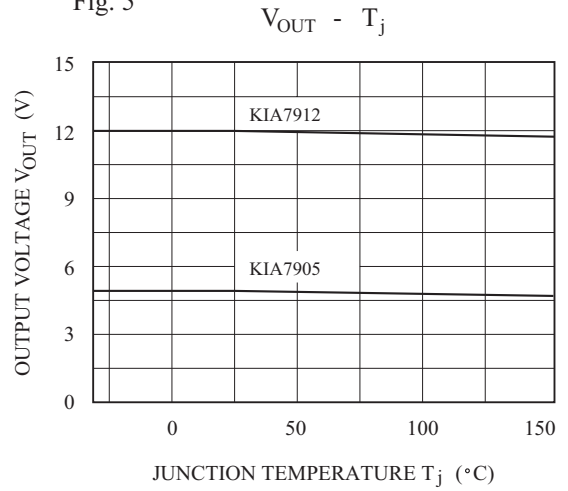

Fig. 6

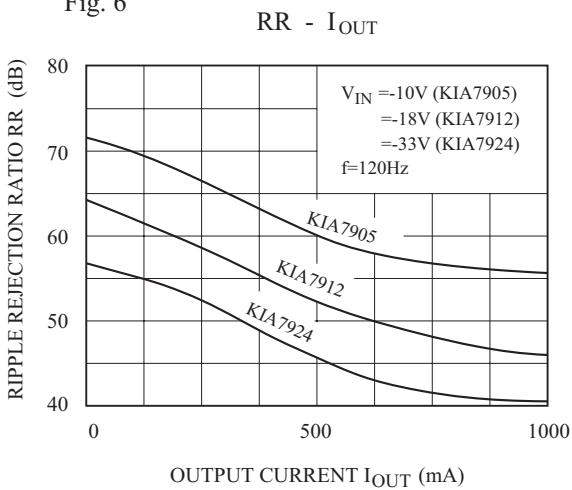

Fig. 7

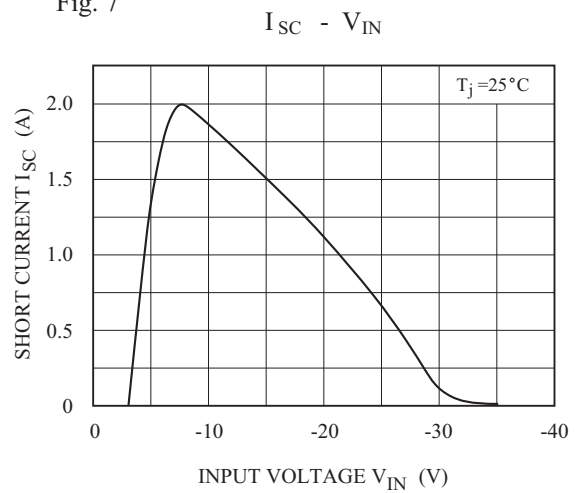

Fig. 8

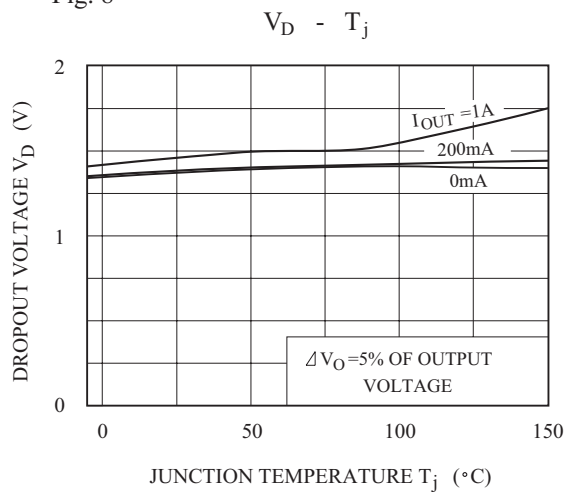
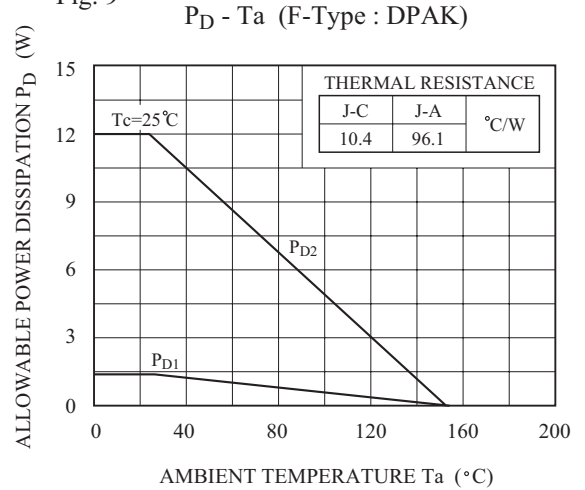
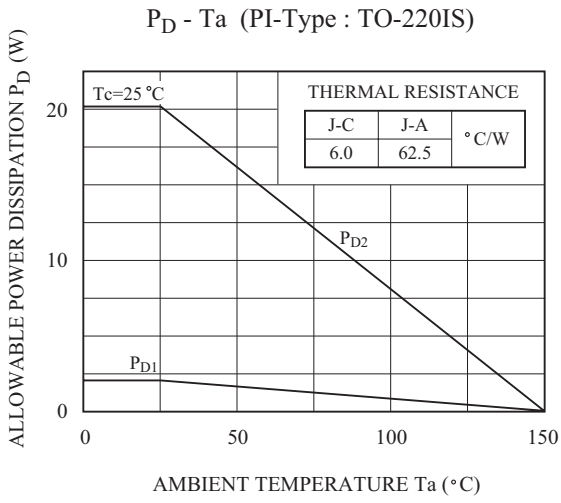

Fig. 9



KIA7905F/PI~KIA7924F/PI



X-ON Electronics

Largest Supplier of Electrical and Electronic Components

Click to view similar products for [Linear Voltage Regulators](#) category:

Click to view products by [KEC](#) manufacturer:

Other Similar products are found below :

[LV5684PVD-XH](#) [MCDTSA6-2R](#) [L7815ACV-DG](#) [LV56801P-E](#) [UA7805CKC](#) [714954EB](#) [ZMR500QFTA](#) [BA033LBSG2-TR](#)
[NCV78M05ABDTRKG](#) [LV5680P-E](#) [L79M05T-E](#) [L78LR05D-MA-E](#) [NCV317MBTG](#) [NTE7227](#) [MP2018GZD-33-P](#) [MP2018GZD-5-P](#)
[LV5680NPVC-XH](#) [ZTS6538SE](#) [UA78L09CLP](#) [UA78L09CLPR](#) [CAT6221-PPTD-GT3](#) [MC78M09CDTRK](#) [NCV51190MNTAG](#)
[BL1118CS8TR1833](#) [BL8563CKETR18](#) [BL8077CKETR33](#) [BL9153-33CC3TR](#) [BL9161G-15BADRN](#) [BL9161G-28BADRN](#)
[BRCO7530MMC](#) [CJ7815B-TFN-ARG](#) [LM317C](#) [GM7333K](#) [GM7350K](#) [XC6206P332MR](#) [HT7533](#) [LM7912S/TR](#) [LT1764S/TR](#) [LM7805T](#)
[LM338T](#) [LM1117IMP-3.3/TR](#) [HT1117AM-3.3](#) [HT7550S](#) [AMS1117-3.3](#) [HT7150S](#) [78L12](#) [HT7550](#) [HT7533-1](#) [HXY6206I-2.5](#) [HT7133](#)