

8CH HIGH-VOLTAGE SOURCE DRIVER

The KID65783BF is comprised of eight source current transistor array. This driver is specifically designed for fluorescent display applications. Applications include relay, lamp drivers.

FEATURES

- High Output Voltage : $V_{CC}=50V(\text{Min.})$.
- Output Current (Single Output) $I_{OUT} : -500mA(\text{Min.})$.
- Output Clamp Diodes.
- Single Supply Voltage.
- Input Compatible With Various Types of Logic.
- Suffix U : Qualified to AEC-Q100
ex) KID65783BF-EL/PU

TYPE	DESIGNATION
KID65783BF	TTL, 5V CMOS

MAXIMUM RATINGS (Ta=25 °C)

CHARACTERISTIC	SYMBOL	RATING	UNIT
Supply Voltage	V_{CC}	50	V
Output Current	I_{OUT}	-500	mA/ch
Input Voltage	V_{IN}	15	V
Clamp Diode Reverse Voltage	V_R	50	V
Clamp Diode Forward Current	I_F	500	mA
Power Dissipation	$P_D(\text{Note})$	0.96	W
Operating Temperature	T_{opr}	-40 85	
Storage Temperature	T_{stg}	-55 150	

Note) Delated above 25 °C in the proportion of 7.7W/ °C.

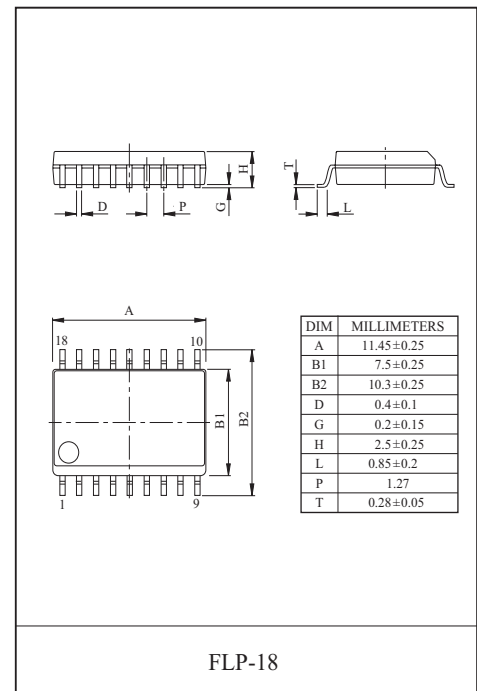

PIN CONNECION (TOP VIEW)

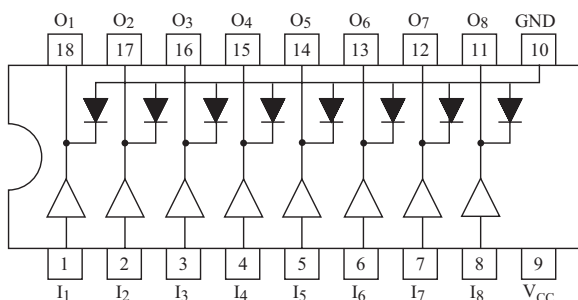

SCHEMATICS (EACH DRIVER)

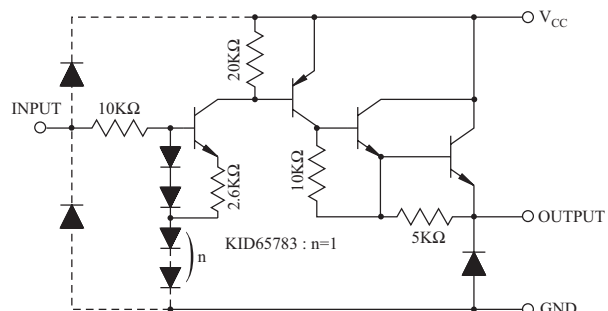

(Note) The input and output parasitic diodes cannot be used as clamp diodes.

KID65783BF

RECOMMENDED OPERATING CONDITIONS (Ta=-40 85)

CHARACTERISTIC		SYMBOL	TEST CONDITION	MIN.	TYP.	MAX.	UNIT	
Supply Voltage		V _{CC}	-	-	-	50	V	
Output Current		I _{OUT}	Ta=85 Tj=120 Tp _w =25mS	Duty=10% 8 Circuits	-	-	-180	mA/ch
				Duty=50% 8 Circuits	-	-	-38	
Input Voltage		V _{IN}	-	-	-	12	V	
Input Voltage	Output ON	V _{IN(ON)}	-	2.0	5.0	15	V	
	Output OFF	V _{IN(OFF)}	-	0	-	0.8		
Clamp Diode Reverse Voltage		V _R	-	-	-	35	V	
Clamp Diode Forward Current		I _F	-	-	-	400	mA	
Power Dissipation		P _D	-	-	-	0.35	W	

ELECTRICAL CHARACTERISTICS (Ta=25)

CHARACTERISTIC	SYMBOL	TEST CIRCUIT	TEST CONDITION	MIN.	TYP.	MAX.	UNIT
Output Leakage Current	I _{CEX}	1	V _{CC} =V _{CC MAX.} V _{IN} =0.4V Ta=25	-	-	100	μA
Output Saturation Voltage	V _{CE(sat)}	2	V _{IN} =V _{IN(ON)} , I _{OUT} =-350mA	-	-	2.0	V
			V _{IN} =V _{IN(ON)} , I _{OUT} =-225mA	-	-	1.9	
			V _{IN} =V _{IN(ON)} , I _{OUT} =-100mA	-	-	1.8	
Input Current	I _{IN(ON)}	3	V _{IN} =2.4V	-	36	52	μA
			V _{IN} =3.85V	-	180	260	
Input Voltage	V _{IN(ON)}	4	V _{CE} =2.0V, I _{OUT} =-350mA	-	-	2.0	V
	V _{IN(OFF)}		I _{OUT} =-500 μA	0.8	-	-	
Supply Current	I _{CC(ON)}	3	V _{IN} =V _{IN(ON)} , V _{CC} =50V	-	-	2.5	mA/ch
Clamp Diode Reverse Current	I _R	5	V _R =50V	-	-	50	μA
Clamp Diode Forward Voltage	V _F	6	I _F =350mA	-	-	2.0	V
Turn-On Delay	t _{ON}	7	V _{CC} =V _{CC MAX.} R _L =125 C _L =15pF	-	0.15	-	μs
Turn-Off Delay	t _{OFF}			-	1.8	-	

KID65783BF

TEST CIRCUIT

1. I_{CEX}

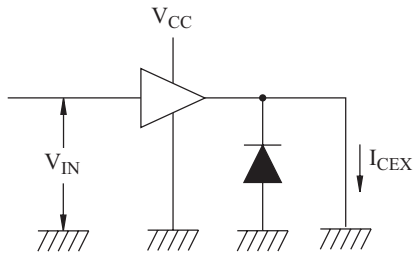

2. $V_{CE(sat)}$

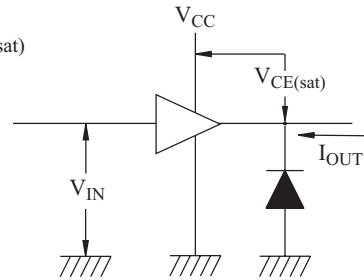

3. $I_{IN(ON)}$, I_{CC}

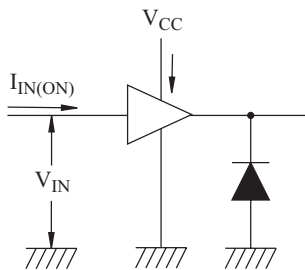

4. $V_{IN(ON)}$, $I_{IN(OFF)}$

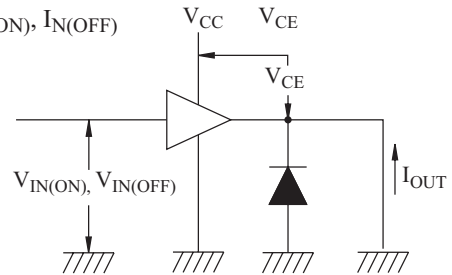

5. I_R

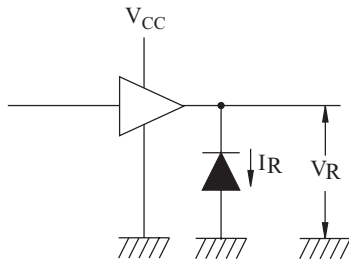

6. V_F

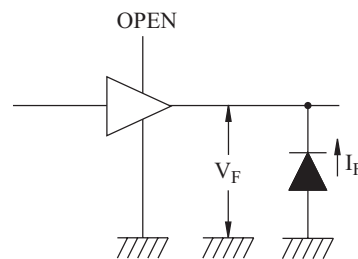

7. t_{ON} , t_{OFF}

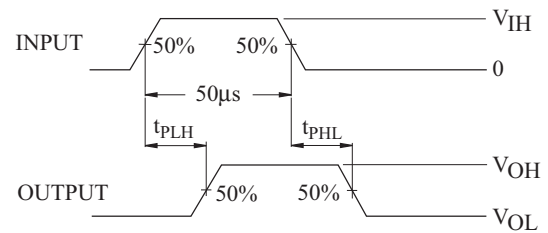
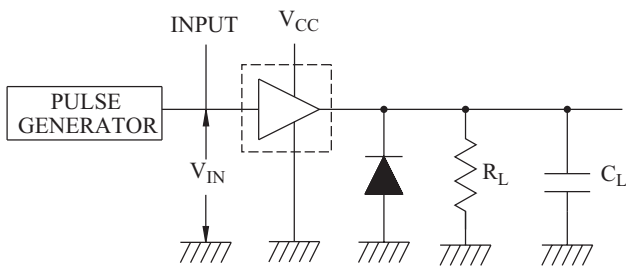

(Note 1) Pulse width 50 μ S, duty cycle 10%
Output impedance 50 Ω , $t \leq 5$ ns, $t \leq 10$ ns

(Note 2) C_L includes probe and jig capacitance

KID65783BF

$I_{OUT} - V_{IN}$

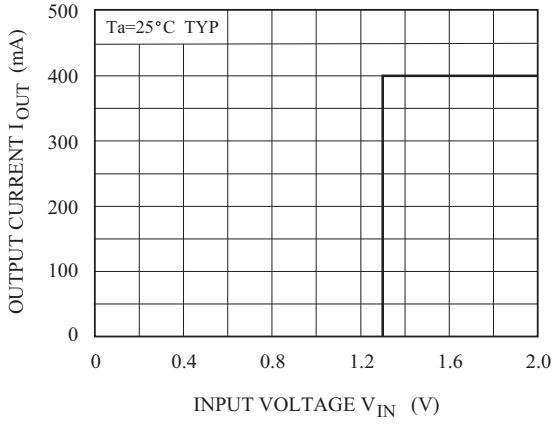

$I_{IN} - V_{IN}$

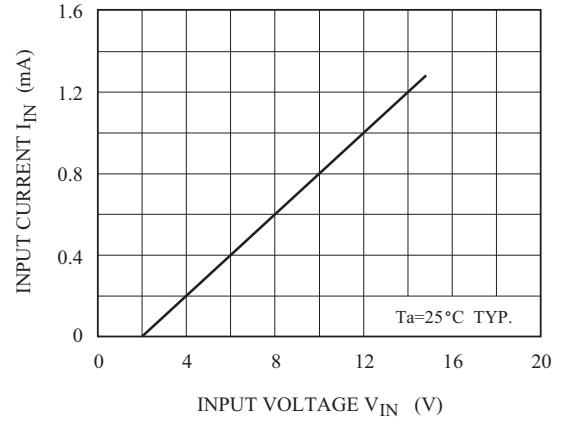

$I_{OUT} - V_{CE(sat)}$

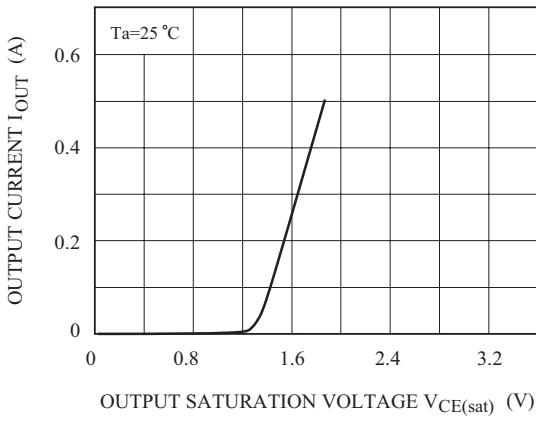

$I_F - V_F$

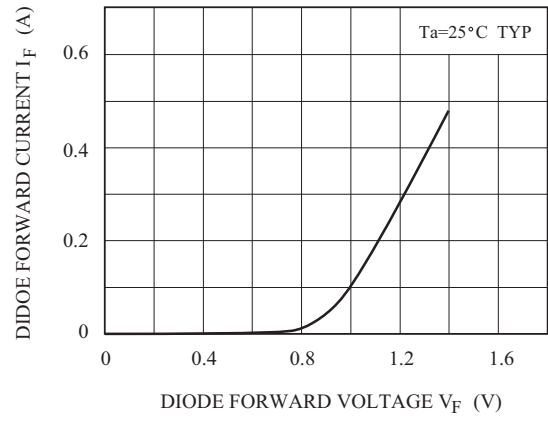

$P_D - T_a$

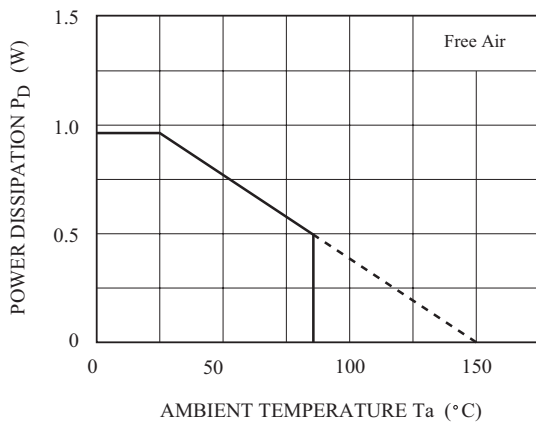

X-ON Electronics

Largest Supplier of Electrical and Electronic Components

Click to view similar products for [Darlington Transistors](#) category:

Click to view products by [KEC](#) manufacturer:

Other Similar products are found below :

[BDV64B](#) [2N6298](#) [NJVMJD117T4G](#) [2N6053](#) [MPSA63](#) [NTE256](#) [TIP120](#) [MJ11028](#) [TIP127](#) [Jantx2N6352](#) [2N6301](#) [NJVBUB323ZT4G](#)
[ULN2803QN](#) [KID65004AF-EL/P](#) [ULN2803CDWR](#) [MJ11033G-JSM](#) [MMBTA64](#) [TPM2003-SO3R](#) [KSP13](#) [TIP127](#) [TIP122](#) [TIP122F](#)
[TIP122-JSM](#) [ULN2003A-JSM](#) [MJ11032G-JSM](#) [KID65783BF-EL/P](#) [ULN2001D\(MS\)](#) [2SD1071](#) [MJ11028](#) [MJ11030](#) [MJ1000](#) [MJ11031](#)
[TIP160](#) [2N6287](#) [MJ11029](#) [MJ3001](#) [MJ2501](#) [ULN2001D\(UMW\)](#) [ULN2003APWR\(UMW\)](#) [ULN2003AIPWR\(UMW\)](#) [ULN2002D\(UMW\)](#)
[ULN2803G-P20-R](#) [WD2002](#) [AIP2003LSA16.TB](#) [AIP2803SA.TR](#) [AIP2803](#) [AIP2803LSA18.TB](#) [XL2803CD](#) [ULN2004MT/TR](#) [MMBTA13](#)