

## Overview

The F622 is constructed of metallized stacked polyester film capacitor with radial leads of tinned wire. Radial leads are electrically welded to the contact metal layer on the ends of the capacitor winding. The capacitor is encapsulated in a self-extinguishing material meeting the requirements of UL 94V-0.

## Applications

Typical applications include high performance, high temperature blocking, coupling, decoupling, bypassing, and interference suppression in low voltage applications such as automotive. Not for use with the mains.

## Benefits

- Voltage range: 50 – 630 VDC
- Capacitance range: 0.001 – 2.2  $\mu$ F
- Lead spacing: 5 mm
- Capacitance tolerance:  $\pm$ 10%,  $\pm$ 20%,  $\pm$ 5% on request
- Climatic category: 55/125/56
- Tape & Reel packaging in accordance with IEC 60286-2
- RoHS compliant and lead-free terminations
- Operating temperature range of  $-55^{\circ}\text{C}$  to  $+125^{\circ}\text{C}$
- Designed for high performance and high temperature applications

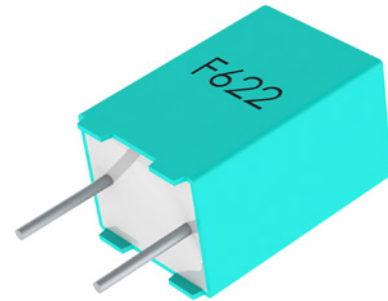

## Part Number System

F	622	J	F	104	M	050	C
Capacitor Class	Series	Lead Spacing (mm)	Size Code	Capacitance Code (pF)	Capacitance Tolerance	Rated Voltage (VDC)	Packaging
F = Film	Metallized polyester	J = 5	See Dimension Table	First two digits represent significant figures. Third digit specifies number of zeros.	J = $\pm$ 5% K = $\pm$ 10% M = $\pm$ 20%	050 = 50 063 = 63 100 = 100 250 = 250 400 = 400 500 = 500 630 = 630	See Ordering Options Table

## Ordering Options Table

Lead Spacing Nominal (mm)	Type of Leads and Packaging	Lead Length (mm)	Lead and Packaging Code
5	<b>Standard lead and packaging options:</b>		
	Bulk – short leads	4 +2/-0	C
	Bulk – long leads	17 +0/-1	A
	Tape & Reel (standard reel)	$H_0 = 18.5 \pm 0.5$	L
	<b>Other lead and packaging options:</b>		
	Bulk – maximum length leads	20 +5/-0	ALL0L
	Ammo pack	$H_0 = 18.5 \pm 0.5$	R

## Dimensions – Millimeters

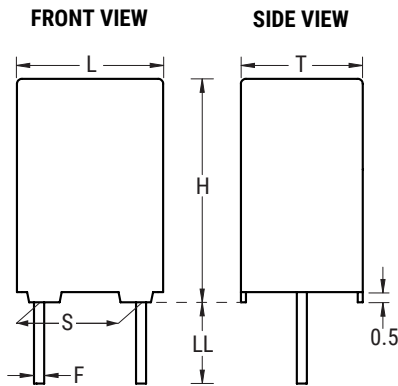

Size Code	S		T		H		L		F	
	Nominal	Tolerance	Nominal	Tolerance	Nominal	Tolerance	Nominal	Tolerance	Nominal	Tolerance
JF	5.0	±0.4	2.5	+0/-0.5	6.5	+0/-0.5	7.2	+0/-0.5	0.5	±0.05
JG	5.0	±0.4	3.5	+0/-0.5	7.5	+0/-0.5	7.2	+0/-0.5	0.5	±0.05
JM	5.0	±0.4	4.5	+0/-0.5	9.5	+0/-0.5	7.2	+0/-0.5	0.5	±0.05
JQ	5.0	±0.4	5.0	+0/-0.5	10.0	+0/-0.5	7.2	+0/-0.5	0.5	±0.05
JT	5.0	±0.4	6.0	+0/-0.5	11.0	+0/-0.5	7.2	+0/-0.5	0.5	±0.05

Note: See Ordering Options Table for lead length (LL) options.

## Performance Characteristics

Capacitance tolerance	±20%, ±10%, ±5% on request			
Temperature range	-55°C to 125°C			
Voltage derating	Above +85°C DC and AC voltage derating is 1.25%/°C			
Rated temperature	+85°C			
Climatic category	-55 to +125°C			
	Average relative humidity ≤ 75%			
	RH = 95% for 30 days per year			
	RH = 85% for further days limited by average value per year			
Test voltage	1.4 x V <sub>R</sub> VDC for 2 seconds			
Capacitance drift	Maximum 3% after a two year storage period at a temperature of +10°C to +40°C and a relative humidity of 40% to 60%			
Reliability	Operational life > 200,000 hours			
	Failure rate < 3 FIT, T = +40°C, V = 0.5 x V <sub>R</sub>			
	Failure criteria: open circuit, short circuit, cap change > 10%, DF two times the catalog limits, IR < 50 MΩ			
Maximum pulse steepness	dv/dt according to article table. For peak to peak voltages lower than rated voltage (V <sub>pp</sub> < V <sub>R</sub> ), the specified dv/dt can be multiplied by the factor V <sub>R</sub> /V <sub>pp</sub>			
Temperature coefficient	+400 (±200) ppm/°C at 1 kHz			
Self inductance	Approximately 6 nH/cm for the total length of capacitor winding and the leads			
Dissipation factor tanδ	Maximum Values at +23°C			
		C ≤ 0.1 μF	0.1 μF < C ≤ 1.0 μF	C > 1.0 μF
Lead spacing 5 mm	1 kHz	0.8%	0.8%	0.8%
	10 kHz	1.2%	1.2%	1.5%
	100 kHz	2.5%		
Insulation resistance	Measured at +20°C, according to IEC 60384-2			
	Minimum Values Between Terminals			
		C ≤ 0.33 μF	C > 0.33 μF and < 1 μF	C > 1.0 μF
	V <sub>R</sub> ≤ 100 VDC	15,000 MΩ	5,000 MΩ · μF	1,000 MΩ · μF
	V <sub>R</sub> > 100 VDC	30,000 MΩ	10,000 MΩ · μF	

## Maximum Voltage ( $V_{rms}$ ) vs. Frequency (sinusoidal wave-form/ $Th \leq 40^\circ C$ )

Lead spacing 5 mm

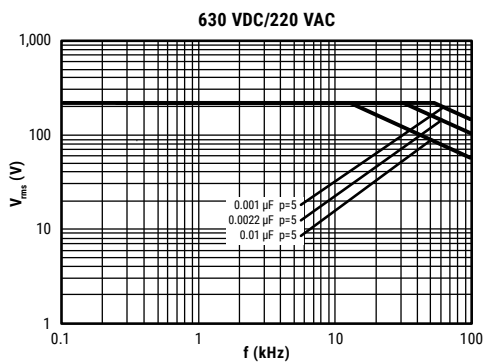
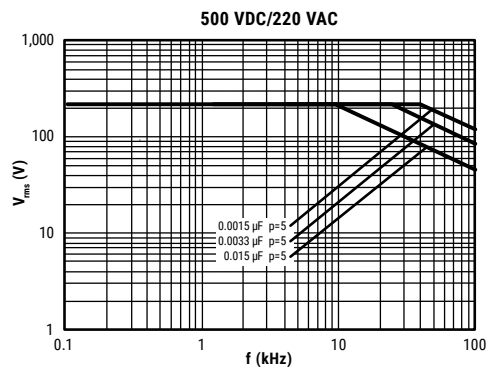
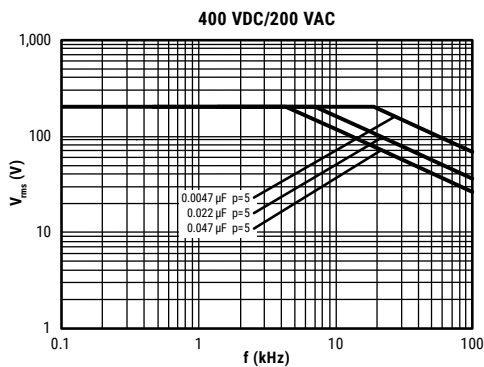
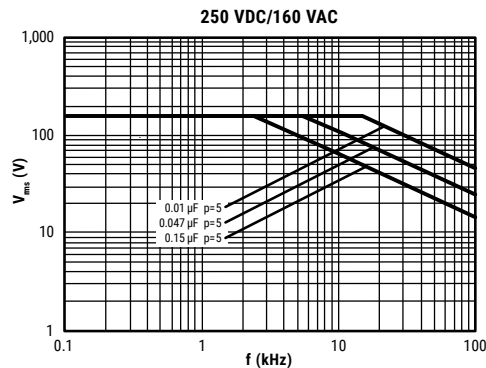
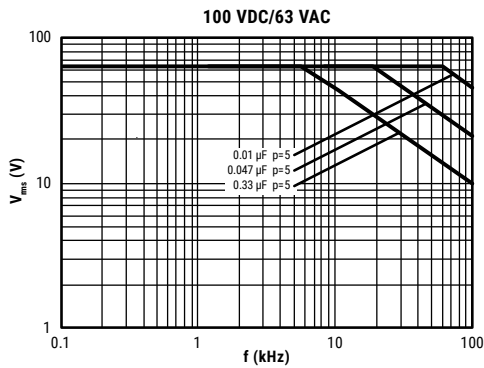
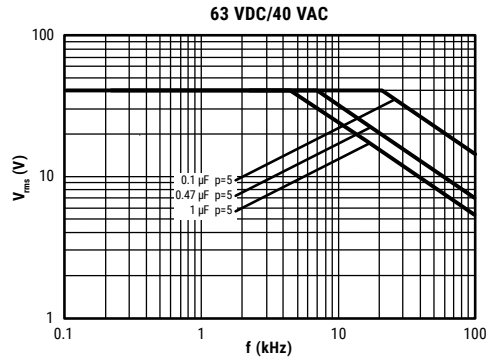
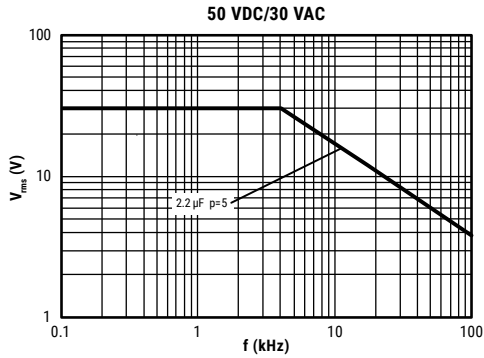

## Maximum Current ( $I_{rms}$ ) vs. Frequency (sinusoidal wave-form/Th $\leq 40^{\circ}\text{C}$ )

Lead spacing 5 mm

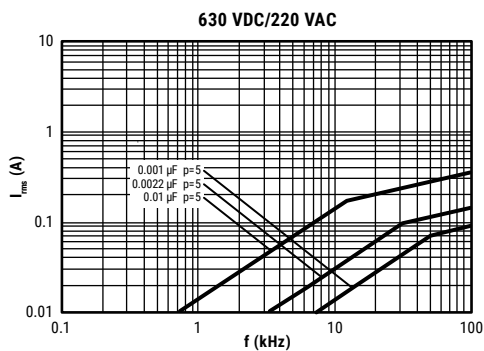
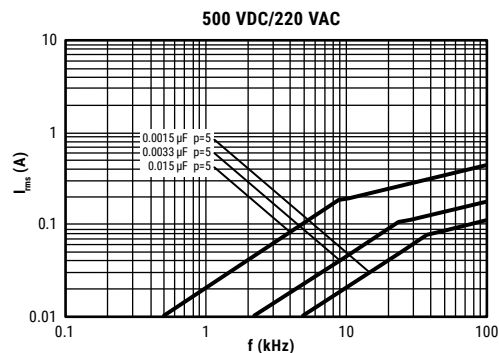
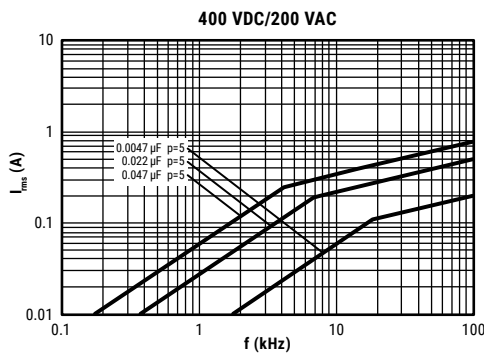
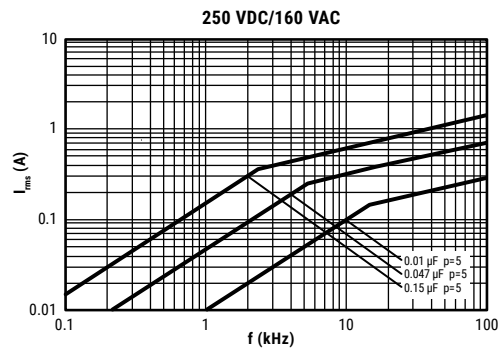
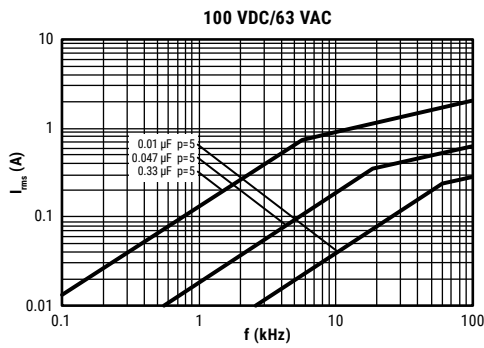
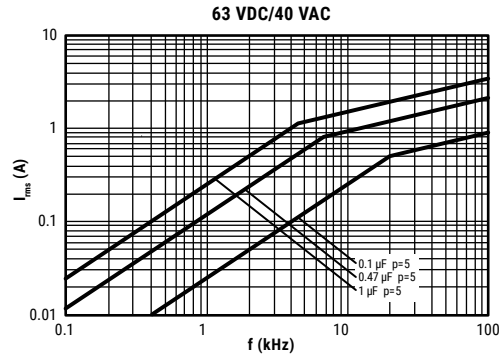
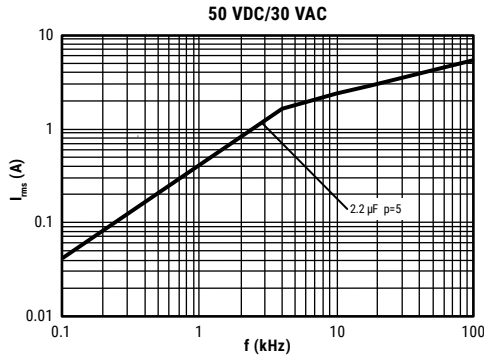

## Environmental Test Data

Damp Heat Test	Test Conditions	T = +40°C, RH = 93%, t = 56 days
	Test Criteria	$\Delta C/C \leq \pm 5\%$ $\Delta \tan\delta \leq 0.005$ (1 kHz) IR after test 0.5 x IR minimum
Endurance Test	Test Conditions	T = +100°C, U = 1.25 x (0.8 x U <sub>R</sub> )
	Test Criteria	t = 2,000 hours $\Delta C/C \leq \pm 5\%$ $\Delta \tan\delta \leq 0.005$ (1 kHz) $\Delta \tan\delta \leq 0.010$ (100 kHz) IR after test 0.5 x IR minimum

## Environmental Compliance

All KEMET MKT capacitors are RoHS compliant and halogen-free.



**Table 1 – Ratings & Part Number Reference**

VDC	VAC	Capacitance Value (µF)	Size Code	Max Dimensions in mm			Lead Spacing (S)	dV/dt (V/µs)	Part Number
				T	H	L			
50	30	2.2	JT	6.0	11.0	7.2	5.0	200	F622JT225(1)050(2)
63	40	0.10	JF	2.5	6.5	7.2	5.0	250	F622JF104(1)063(2)
63	40	0.12	JF	2.5	6.5	7.2	5.0	250	F622JF124(1)063(2)
63	40	0.15	JF	2.5	6.5	7.2	5.0	250	F622JF154(1)063(2)
63	40	0.18	JF	2.5	6.5	7.2	5.0	250	F622JF184(1)063(2)
63	40	0.22	JF	2.5	6.5	7.2	5.0	250	F622JF224(1)063(2)
63	40	0.27	JG	3.5	7.5	7.2	5.0	250	F622JG274(1)063(2)
63	40	0.33	JG	3.5	7.5	7.2	5.0	250	F622JG334(1)063(2)
63	40	0.39	JG	3.5	7.5	7.2	5.0	250	F622JG394(1)063(2)
63	40	0.47	JG	3.5	7.5	7.2	5.0	250	F622JG474(1)063(2)
63	40	0.56	JM	4.5	9.5	7.2	5.0	250	F622JM564(1)063(2)
63	40	0.68	JM	4.5	9.5	7.2	5.0	250	F622JM684(1)063(2)
63	40	0.82	JM	4.5	9.5	7.2	5.0	250	F622JM824(1)063(2)
63	40	1.0	JQ	5.0	10.0	7.2	5.0	250	F622JQ105(1)063(2)
63	40	1.2	JT	6.0	11.0	7.2	5.0	250	F622JT125(1)063(2)
63	40	1.5	JT	6.0	11.0	7.2	5.0	250	F622JT155(1)063(2)
100	63	0.0047	JF	2.5	6.5	7.2	5.0	300	F622JF472(1)100(2)
100	63	0.0056	JF	2.5	6.5	7.2	5.0	300	F622JF562(1)100(2)
100	63	0.0068	JF	2.5	6.5	7.2	5.0	300	F622JF682(1)100(2)
100	63	0.0082	JF	2.5	6.5	7.2	5.0	300	F622JF822(1)100(2)
100	63	0.010	JF	2.5	6.5	7.2	5.0	300	F622JF103(1)100(2)
100	63	0.012	JF	2.5	6.5	7.2	5.0	300	F622JF123(1)100(2)
100	63	0.015	JF	2.5	6.5	7.2	5.0	300	F622JF153(1)100(2)
100	63	0.018	JF	2.5	6.5	7.2	5.0	300	F622JF183(1)100(2)
100	63	0.022	JF	2.5	6.5	7.2	5.0	300	F622JF223(1)100(2)
100	63	0.027	JF	2.5	6.5	7.2	5.0	300	F622JF273(1)100(2)
100	63	0.033	JF	2.5	6.5	7.2	5.0	300	F622JF333(1)100(2)
100	63	0.039	JF	2.5	6.5	7.2	5.0	300	F622JF393(1)100(2)
100	63	0.047	JF	2.5	6.5	7.2	5.0	300	F622JF473(1)100(2)
100	63	0.056	JF	2.5	6.5	7.2	5.0	300	F622JF563(1)100(2)
100	63	0.068	JF	2.5	6.5	7.2	5.0	300	F622JF683(1)100(2)
100	63	0.082	JG	3.5	7.5	7.2	5.0	300	F622JG823(1)100(2)
100	63	0.10	JG	3.5	7.5	7.2	5.0	300	F622JG104(1)100(2)
100	63	0.12	JM	4.5	9.5	7.2	5.0	300	F622JM124(1)100(2)
100	63	0.15	JM	4.5	9.5	7.2	5.0	300	F622JM154(1)100(2)
100	63	0.18	JM	4.5	9.5	7.2	5.0	300	F622JM184(1)100(2)
100	63	0.22	JQ	5.0	10.0	7.2	5.0	300	F622JQ224(1)100(2)
100	63	0.27	JT	6.0	11.0	7.2	5.0	300	F622JT274(1)100(2)
100	63	0.33	JT	6.0	11.0	7.2	5.0	300	F622JT334(1)100(2)
100	63	0.39	JT	6.0	11.0	7.2	5.0	300	F622JT394(1)100(2)
100	63	0.47	JT	6.0	11.0	7.2	5.0	300	F622JT474(1)100(2)
250	160	0.0010	JF	2.5	6.5	7.2	5.0	400	F622JF102(1)250(2)
250	160	0.0012	JF	2.5	6.5	7.2	5.0	400	F622JF122(1)250(2)
250	160	0.0015	JF	2.5	6.5	7.2	5.0	400	F622JF152(1)250(2)
250	160	0.0018	JF	2.5	6.5	7.2	5.0	400	F622JF182(1)250(2)
250	160	0.0022	JF	2.5	6.5	7.2	5.0	400	F622JF222(1)250(2)
250	160	0.0027	JF	2.5	6.5	7.2	5.0	400	F622JF272(1)250(2)
250	160	0.0033	JF	2.5	6.5	7.2	5.0	400	F622JF332(1)250(2)
250	160	0.0039	JF	2.5	6.5	7.2	5.0	400	F622JF392(1)250(2)
250	160	0.0047	JF	2.5	6.5	7.2	5.0	400	F622JF472(1)250(2)
250	160	0.0056	JF	2.5	6.5	7.2	5.0	400	F622JF562(1)250(2)
250	160	0.0068	JF	2.5	6.5	7.2	5.0	400	F622JF682(1)250(2)
250	160	0.082	JF	2.5	6.5	7.2	5.0	400	F622JF823(1)250(2)
250	160	0.010	JF	2.5	6.5	7.2	5.0	400	F622JF103(1)250(2)
250	160	0.012	JF	2.5	6.5	7.2	5.0	400	F622JF123(1)250(2)
250	160	0.015	JF	2.5	6.5	7.2	5.0	400	F622JF153(1)250(2)
250	160	0.018	JF	2.5	6.5	7.2	5.0	400	F622JF183(1)250(2)
250	160	0.022	JG	3.5	7.5	7.2	5.0	400	F622JG223(1)250(2)
250	160	0.027	JG	3.5	7.5	7.2	5.0	400	F622JG273(1)250(2)
VDC	VAC	Capacitance Value (µF)	Size Code	T (mm)	H (mm)	L (mm)	Lead Spacing (S)	dV/dt (V/µs)	Part Number

(1) K = ±10%, M = ±20%, J = ±5% on request.

(2) Insert lead and packaging code. See table for available options.

**Table 1 – Ratings & Part Number Reference cont.**

VDC	VAC	Capacitance Value (µF)	Size Code	Max Dimensions in mm			Lead Spacing (S)	dV/dt (V/µs)	Part Number
				T	H	L			
250	160	0.033	JG	3.5	7.5	7.2	5.0	400	F622JG333(1)250(2)
250	160	0.039	JG	3.5	7.5	7.2	5.0	400	F622JG393(1)250(2)
250	160	0.047	JM	4.5	9.5	7.2	5.0	400	F622JM473(1)250(2)
250	160	0.056	JM	4.5	9.5	7.2	5.0	400	F622JM563(1)250(2)
250	160	0.068	JM	4.5	9.5	7.2	5.0	400	F622JM683(1)250(2)
250	160	0.082	JM	4.5	9.5	7.2	5.0	400	F622JM823(1)250(2)
250	160	0.10	JQ	5.0	10.0	7.2	5.0	400	F622JQ104(1)250(2)
250	160	0.12	JT	6.0	11.0	7.2	5.0	400	F622JT124(1)250(2)
250	160	0.15	JT	6.0	11.0	7.2	5.0	400	F622JT154(1)250(2)
400	200	0.0010	JF	2.5	6.5	7.2	5.0	600	F622JF102(1)400(2)
400	200	0.0012	JF	2.5	6.5	7.2	5.0	600	F622JF122(1)400(2)
400	200	0.0015	JF	2.5	6.5	7.2	5.0	600	F622JF152(1)400(2)
400	200	0.0018	JF	2.5	6.5	7.2	5.0	600	F622JF182(1)400(2)
400	200	0.0022	JF	2.5	6.5	7.2	5.0	600	F622JF222(1)400(2)
400	200	0.0027	JF	2.5	6.5	7.2	5.0	600	F622JF272(1)400(2)
400	200	0.0033	JF	2.5	6.5	7.2	5.0	600	F622JF332(1)400(2)
400	200	0.0039	JF	2.5	6.5	7.2	5.0	600	F622JF392(1)400(2)
400	200	0.0047	JF	2.5	6.5	7.2	5.0	600	F622JF472(1)400(2)
400	200	0.0056	JG	3.5	7.5	7.2	5.0	600	F622JG562(1)400(2)
400	200	0.0068	JG	3.5	7.5	7.2	5.0	600	F622JG682(1)400(2)
400	200	0.0082	JG	3.5	7.5	7.2	5.0	600	F622JG822(1)400(2)
400	200	0.010	JG	3.5	7.5	7.2	5.0	600	F622JG103(1)400(2)
400	200	0.012	JG	3.5	7.5	7.2	5.0	600	F622JG123(1)400(2)
400	200	0.015	JG	3.5	7.5	7.2	5.0	600	F622JG153(1)400(2)
400	200	0.018	JM	4.5	9.5	7.2	5.0	600	F622JM183(1)400(2)
400	200	0.022	JM	4.5	9.5	7.2	5.0	600	F622JM223(1)400(2)
400	200	0.027	JM	4.5	9.5	7.2	5.0	600	F622JM273(1)400(2)
400	200	0.033	JQ	5.0	10.0	7.2	5.0	600	F622JQ333(1)400(2)
400	200	0.039	JQ	5.0	10.0	7.2	5.0	600	F622JQ393(1)400(2)
400	200	0.047	JT	6.0	11.0	7.2	5.0	600	F622JT473(1)400(2)
400	200	0.056	JT	6.0	11.0	7.2	5.0	600	F622JT563(1)400(2)
500	220	0.0010	JF	2.5	6.5	7.2	5.0	700	F622JF102(1)500(2)
500	220	0.0012	JF	2.5	6.5	7.2	5.0	700	F622JF122(1)500(2)
500	220	0.0015	JF	2.5	6.5	7.2	5.0	700	F622JF152(1)500(2)
500	220	0.0018	JF	2.5	6.5	7.2	5.0	700	F622JF182(1)500(2)
500	220	0.0022	JG	3.5	7.5	7.2	5.0	700	F622JG222(1)500(2)
500	220	0.0027	JG	3.5	7.5	7.2	5.0	700	F622JG272(1)500(2)
500	220	0.0033	JG	3.5	7.5	7.2	5.0	700	F622JG332(1)500(2)
500	220	0.0039	JG	3.5	7.5	7.2	5.0	700	F622JG392(1)500(2)
500	220	0.0047	JG	3.5	7.5	7.2	5.0	700	F622JG472(1)500(2)
500	220	0.0056	JM	4.5	9.5	7.2	5.0	700	F622JM562(1)500(2)
500	220	0.0068	JM	4.5	9.5	7.2	5.0	700	F622JM682(1)500(2)
500	220	0.0082	JM	4.5	9.5	7.2	5.0	700	F622JM822(1)500(2)
500	220	0.010	JQ	5.0	10.0	7.2	5.0	700	F622JQ103(1)500(2)
500	220	0.012	JT	6.0	11.0	7.2	5.0	700	F622JT123(1)500(2)
500	220	0.015	JT	6.0	11.0	7.2	5.0	700	F622JT153(1)500(2)
630	220	0.0010	JF	2.5	6.5	7.2	5.0	800	F622JF102(1)630(2)
630	220	0.0012	JF	2.5	6.5	7.2	5.0	800	F622JF122(1)630(2)
630	220	0.0015	JG	3.5	7.5	7.2	5.0	800	F622JG152(1)630(2)
630	220	0.0018	JG	3.5	7.5	7.2	5.0	800	F622JG182(1)630(2)
630	220	0.0022	JG	3.5	7.5	7.2	5.0	800	F622JG222(1)630(2)
630	220	0.0027	JG	3.5	7.5	7.2	5.0	800	F622JG272(1)630(2)
630	220	0.0033	JM	4.5	9.5	7.2	5.0	800	F622JM332(1)630(2)
630	220	0.0039	JM	4.5	9.5	7.2	5.0	800	F622JM392(1)630(2)
630	220	0.0047	JM	4.5	9.5	7.2	5.0	800	F622JM472(1)630(2)
630	220	0.0056	JM	4.5	9.5	7.2	5.0	800	F622JM562(1)630(2)
630	220	0.0068	JQ	5.0	10.0	7.2	5.0	800	F622JQ682(1)630(2)
630	220	0.0082	JT	6.0	11	7.2	5.0	800	F622JT822(1)630(2)
630	220	0.010	JT	6.0	11	7.2	5.0	800	F622JT103(1)630(2)
VDC	VAC	Capacitance Value (µF)	Size Code	T (mm)	H (mm)	L (mm)	Lead Spacing (S)	dV/dt (V/µs)	Part Number

(1) K = ±10%, M = ±20%, J = ±5% on request.

(2) Insert lead and packaging code. See table for available options.



## Soldering Process

The implementation of the RoHS directive has resulted in the selection of SnAuCu (SAC) alloys or SnCu alloys as primary solder. This has increased the liquidus temperature from that of 183°C for SnPb eutectic alloy to 217 – 221°C for the new alloys. As a result, the heat stress to the components, even in wave soldering, has increased considerably due to higher pre-heat and wave temperatures. Polypropylene capacitors are especially sensitive to heat (the melting point of polypropylene is 160 – 170°C). Wave soldering can be destructive, especially for mechanically small polypropylene capacitors (with lead spacing of 5 – 15 mm), and great care has to be taken during soldering. In general, the wave soldering curve from IEC Publication 61760-1 Edition 2 serves as a solid guideline for successful soldering. Please see Figure 1. The recommended solder profiles from KEMET should be used. Please consult KEMET with any questions.

Reflow soldering is not recommended for through-hole film capacitors. Exposing capacitors to a soldering profile in excess of the above the recommended limits may result to degradation or permanent damage to the capacitors.

Do not place the polypropylene capacitor through an adhesive curing oven to cure resin for surface mount components. Insert through-hole parts after the curing of surface mount parts. Consult KEMET to discuss the actual temperature profile in the oven, if through-hole components must pass through the adhesive curing process. A maximum two soldering cycles is recommended. Please allow time for the capacitor surface temperature to return to a normal temperature before the second soldering cycle.

### Manual Soldering Recommendations

Following is the recommendation for manual soldering with a soldering iron.

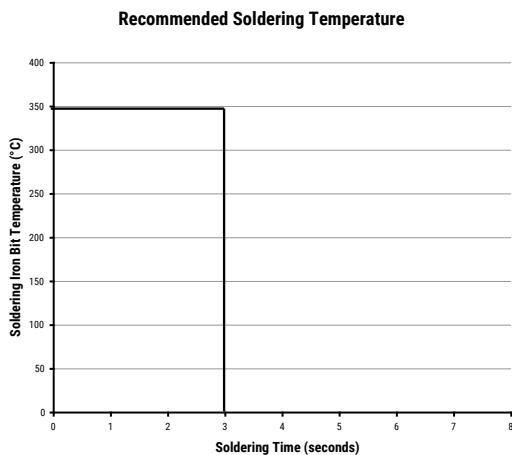

Soldering iron tip temperature should be set at 350°C (+10°C maximum) with the soldering duration not to exceed more than three seconds.

### Wave Soldering Recommendations

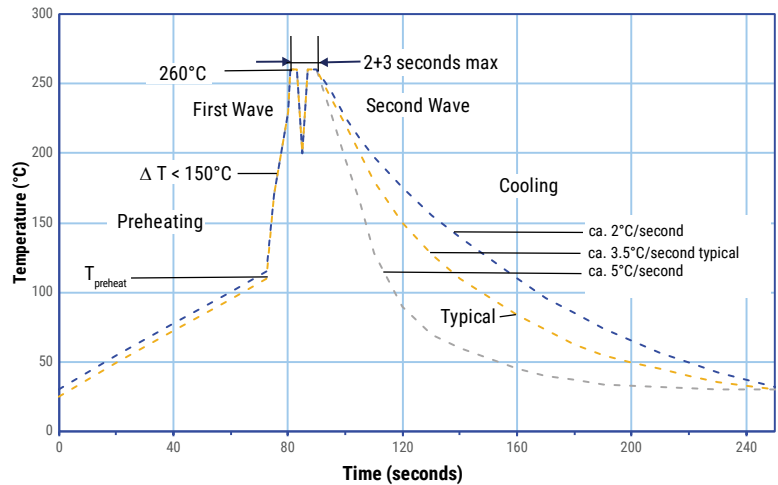

## Soldering Process cont.

### Wave Soldering Recommendations cont.

1. The table indicates the maximum set-up temperature of the soldering process  
 Figure 1

Dielectric Film Material	Maximum Preheat Temperature			Maximum Peak Soldering Temperature	
	Capacitor pitch ≤ 10 mm	Capacitor pitch = 15 mm	Capacitor pitch > 15 mm	Capacitor pitch ≤ 15 mm	Capacitor pitch > 15 mm
Polyester	130°C	130°C	130°C	270°C	270°C
Polypropylene	110°C	110°C	130°C	260°C	270°C
Paper	130°C	130°C	140°C	270°C	270°C
Polyphenylene Sulphide	150°C	150°C	160°C	270°C	270°C

2. The maximum temperature measured inside the capacitor:

Set the temperature so that inside the element the maximum temperature is below the limit:

Dielectric Film Material	Maximum temperature measured inside the element
Polyester	160°C
Polypropylene	110°C
Paper	160°C
Polyphenylene Sulphide	160°C

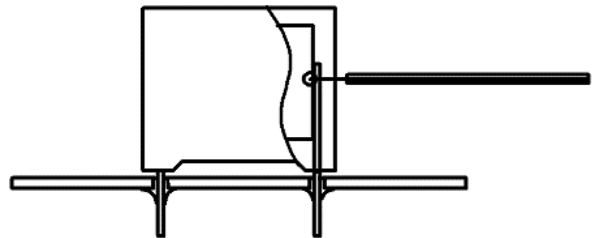

*Temperature monitored inside the capacitor.*

### Selective Soldering Recommendations

Selective dip soldering is a variation of reflow soldering. In this method, the printed circuit board with through-hole components to be soldered is preheated and transported over the solder bath as in normal flow soldering without touching the solder. When the board is over the bath, it is stopped, and pre-designed solder pots are lifted from the bath with molten solder only at the places of the selected components and pressed against the lower surface of the board to solder the components.

The temperature profile for selective soldering is similar to the double wave flow soldering outlined in this document; **however, instead of two baths, there is only one bath with a time of 3 to 10 seconds.** In selective soldering, the risk of overheating is greater than in double wave flow soldering, and great care must be taken so that the parts are not overheated.

## Construction

### Stacked

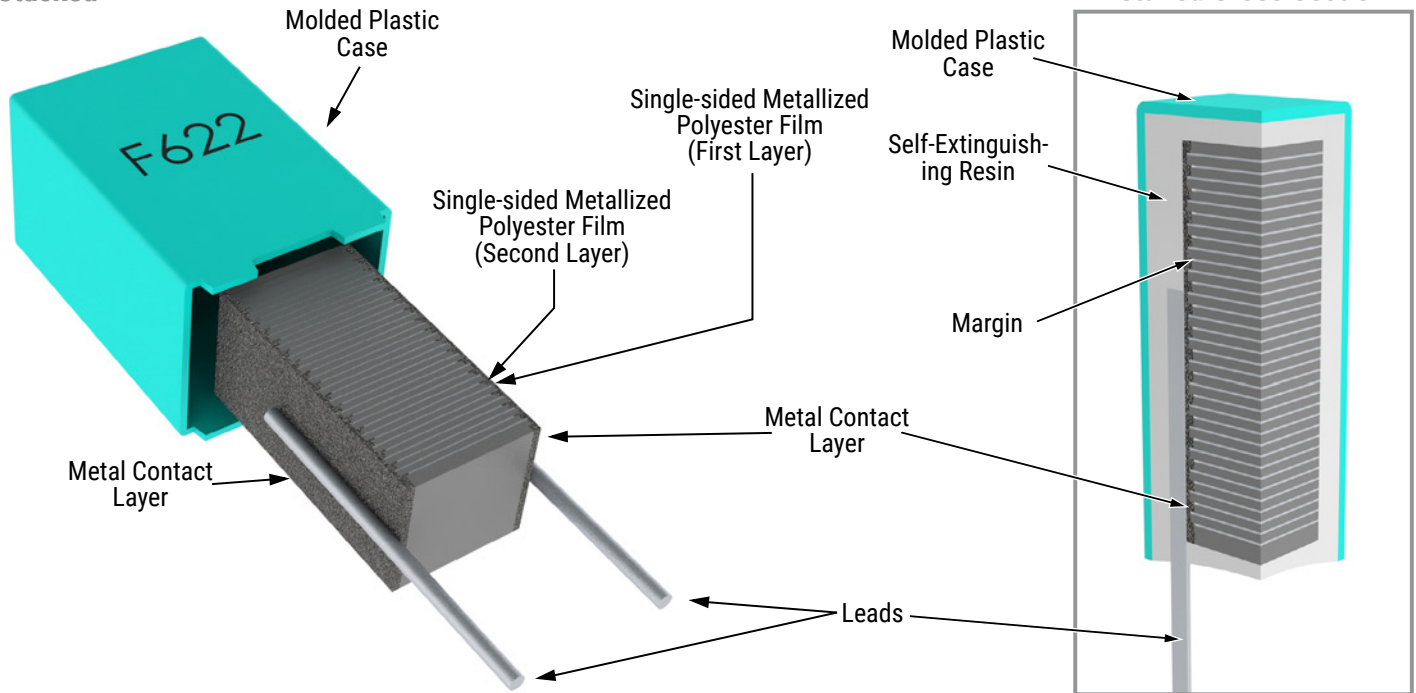

## Marking

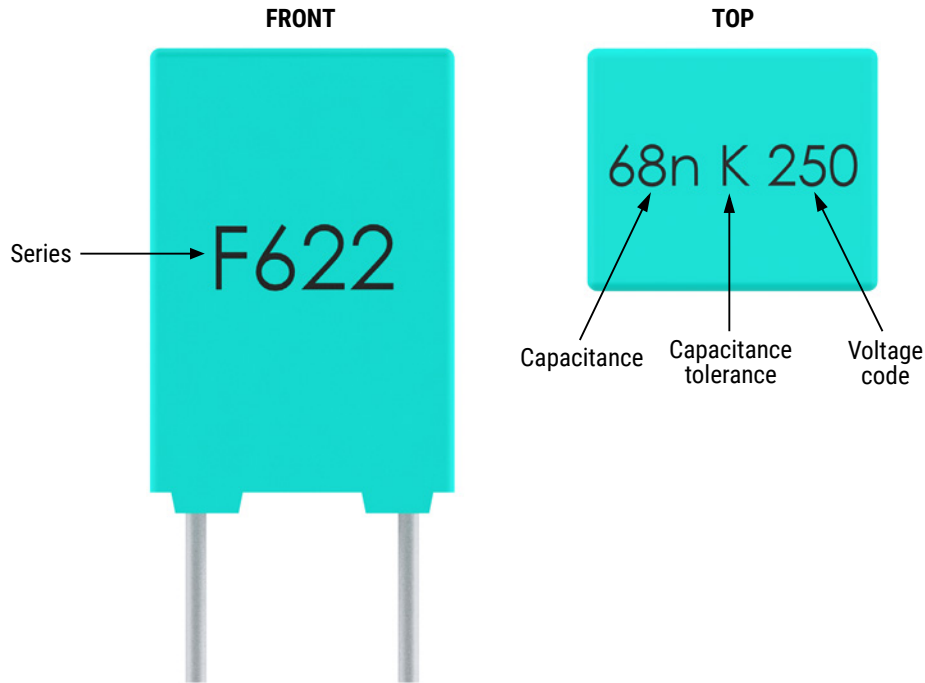

## Packaging Quantities

Size Code	Lead Spacing	Thickness (mm)	Height (mm)	Length (mm)	Bulk Short leads	Bulk Long leads	Standard Reel 355 mm	Ammo
JF	5.0	2.5	6.5	7.2	3,000	4,000	2,500	3,500
JG		3.5	7.5	7.2	2,000	3,000	1,800	2,500
JM		4.5	9.5	7.2	1,500	2,000	1,400	1,900
JQ		5.0	10.0	7.2	1,000	1,500	1,200	1,700
JT		6.0	11.0	7.2	2,000	1,000	1,000	1,400
JU		7.2	13.0	7.2	1,500	750	800	1,150

## Lead Taping & Packaging (IEC 60286-2)

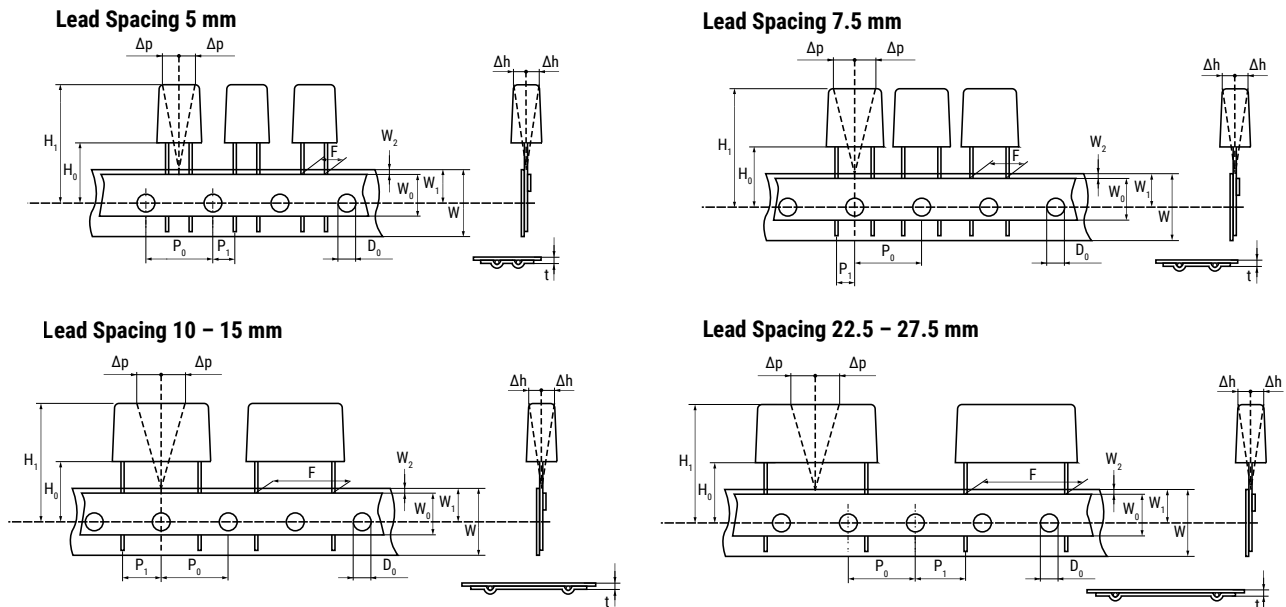

## Taping Specification

Dimensions in mm									Standard IEC 60286-2
Lead Spacing	+0.6/-0.1	F	5.0	7.5	10.0	15.0	22.5	27.5	F
Carrier Tape Width	+1/-0.5	W	18.0	18.0	18.0	18.0	18.0	18.0	18 <sup>+1/-0.5</sup>
Hold-Down Tape Width	Minimum	W <sub>0</sub>	6.0	6.0	9.0	10.0	10.0	10.0	
Position of Sprocket Hole	±0.5	W <sub>1</sub>	9.0	9.0	9.0	9.0	9.0	9.0	9 <sup>+0.75/-0.5</sup>
Distance Between Tapes	Maximum	W <sub>2</sub>	3.0	3.0	3.0	3.0	3.0	3.0	3.0
Sprocket Hole Diameter	±0.2	D <sub>0</sub>	4.0	4.0	4.0	4.0	4.0	4.0	4.0
Feed Hole Lead Spacing	±0.2 <sup>(1)</sup>	P <sub>0</sub> <sup>(3)</sup>	12.7	12.7	12.7	12.7	12.7	12.7	12.7
Distance Lead – Feed Hole	±0.7	P <sub>1</sub>	3.85	3.75	7.7	5.2	7.8	5.3	P <sup>1</sup>
Deviation Tape – Plane	Maximum	Δp	1.3	1.3	1.3	1.3	1.3	1.3	1.3
Lateral Deviation	±2	Δh	2.0	2.0	2.0	2.0	2.0	2.0	2.0
Total Thickness	±0.2	t	0.7	0.7	0.7	0.7	0.9 <sup>MAX</sup>	0.9 <sup>MAX</sup>	0.9 <sup>MAX</sup>
Sprocket Hole/Cap Body	±0.5	H <sub>0</sub> <sup>(2)</sup>	18.5 <sup>±0.5</sup>	18.5 <sup>±0.5</sup>	18.5 <sup>±0.5</sup>	18.5 <sup>±0.5</sup>	18.5 <sup>±0.5</sup>	18.5 <sup>±0.5</sup>	18 <sup>+2/-0</sup>

(1) Maximum cumulative feed hole error, 1 mm per 20 parts.

(2) 16.5 mm available on request.

(3) 15 mm available on request (F ≥ 10 mm).

## Lead Taping & Packaging (IEC 60286-2) cont.

### Ammo Specifications

Series	Dimensions (mm)		
	H	W	T
R4x, R4x+R, R7x, RSB	360	340	59
F5A, F5B, F5D			
F6xx, F8xx			
PHExxx, PMExxx, PMRxxx	330	330	50

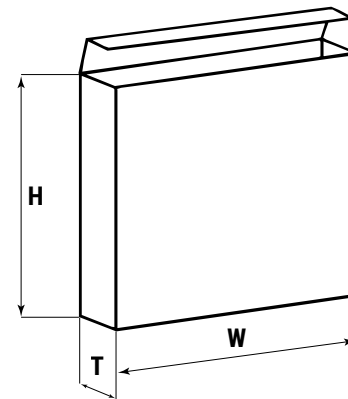

### Reel Specifications

Series	Dimensions (mm)		
	D	H	W
R4x, R4x+R, R7x, RSB	355 500	30	55 (Max)
F5A, F5B, F5D		25	
F6xx, F8xx			
PHExxx, PMExxx, PMRxxx	360 500	30	46 (Max)

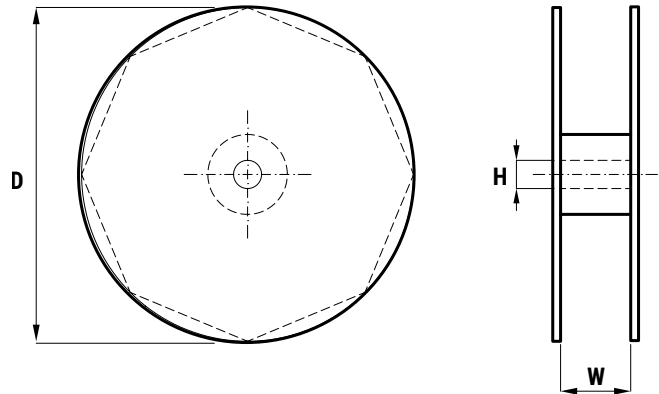

### Manufacturing Date Code (IEC-60062)

Y = Year, Z = Month			
Year	Code	Month	Code
2010	A	January	1
2011	B	February	2
2012	C	March	3
2013	D	April	4
2014	E	May	5
2015	F	June	6
2016	H	July	7
2017	J	August	8
2018	K	September	9
2019	L	October	O
2020	M	November	N
2021	N	December	D
2022	P		
2023	R		
2024	S		
2025	T		
2026	U		
2027	V		
2028	W		
2029	X		
2030	A		

## KEMET Electronics Corporation Sales Offices

For a complete list of our global sales offices, please visit [www.kemet.com/sales](http://www.kemet.com/sales).

---

### Disclaimer

All product specifications, statements, information and data (collectively, the "Information") in this datasheet are subject to change. The customer is responsible for checking and verifying the extent to which the Information contained in this publication is applicable to an order at the time the order is placed. All Information given herein is believed to be accurate and reliable, but it is presented without guarantee, warranty, or responsibility of any kind, expressed or implied.

Statements of suitability for certain applications are based on KEMET Electronics Corporation's ("KEMET") knowledge of typical operating conditions for such applications, but are not intended to constitute – and KEMET specifically disclaims – any warranty concerning suitability for a specific customer application or use. The Information is intended for use only by customers who have the requisite experience and capability to determine the correct products for their application. Any technical advice inferred from this Information or otherwise provided by KEMET with reference to the use of KEMET's products is given gratis, and KEMET assumes no obligation or liability for the advice given or results obtained.

Although KEMET designs and manufactures its products to the most stringent quality and safety standards, given the current state of the art, isolated component failures may still occur. Accordingly, customer applications which require a high degree of reliability or safety should employ suitable designs or other safeguards (such as installation of protective circuitry or redundancies) in order to ensure that the failure of an electrical component does not result in a risk of personal injury or property damage.

Although all product-related warnings, cautions and notes must be observed, the customer should not assume that all safety measures are indicated or that other measures may not be required.

*KEMET is a registered trademark of KEMET Electronics Corporation.*

## X-ON Electronics

Largest Supplier of Electrical and Electronic Components

*Click to view similar products for [Film Capacitors](#) category:*

*Click to view products by [Kemet](#) manufacturer:*

Other Similar products are found below :

[F450KG153J250ALH0J](#) [750-1018](#) [FKP1-1000160010P15](#) [FKP1-1500160010P15](#) [82EC1100DQ50K](#) [MMWAF150KME](#)  
[PFR5101J100J11L16.5TA18](#) [PME261JB5220KR19T0](#) [A521HH333M035C](#) [A561ED221M450A](#) [QXJ2E474KTPT](#) [QXL2B333KTPT](#)  
[QXM2G104K](#) [DMT2P22](#) [EEC2G505HQA406](#) [B32520C6332K000](#) [B32522C6104K000](#) [B32676E6755K](#) [C3B2AD44400B20K](#)  
[SCD105K122A3-22](#) [2N3155](#) [F601BL225K063CL60A](#) [FKP1-2202KV5P15](#) [FKS3-680040010P10](#) [445450-1](#) [B32523Q0475K000](#)  
[46KR415050M1K](#) [4BSNBX4100ZBFJ](#) [4DCNAQ4450ZA0J](#) [MKP383510063JKP2T0](#) [MKT 1813-368-015](#) [MKT182022263473](#) [4055292001](#)  
[WMC08P22](#) [WMF1S15](#) [WMF4S68](#) [EEC2E106HQA405](#) [EEC2G805HQA415](#) [82DC3100DQ50J](#) [82EC2150DQ50K](#) [WMF4D68](#) [WMF1D68](#)  
[B25620B118K883](#) [ECW-F2105JAC](#) [B25620B158K883](#) [66MD2100CK7AK](#) [A521HH471M450C](#) [97F8038](#) [NRM-S225K250F](#)  
[730P205X9400](#)