

R79 Series Single Metallized Polypropylene Film, Radial, 5 mm Lead Spacing, Multipurpose Applications

Overview

The R79 Series is constructed of metallized polypropylene film with radial leads of tinned wire. The radial leads are electrically welded to the metal layer on the ends of the capacitor winding. The capacitor is encapsulated in a self-extinguishing solvent resistant plastic case with thermosetting resin material meeting the UL 94V-0 requirements.

Applications

Typical applications include timing, oscillator circuits, high frequency coupling and decoupling applications. Not suitable for across-the-line application (see Suppressor Capacitors).

Benefits

- Voltage range: 160 – 630 VDC
- Capacitance range: 0.001 – 0.22 μ F
- Lead Spacing: 5 mm
- Capacitance tolerance: \pm 5%, \pm 10%, \pm 20%
- Climatic category: 55/105/56 IEC 60068-1
- Operating temperature range of -55°C to +105°C
- RoHS compliance and lead-free terminations
- Tape and reel packaging in accordance with IEC 60286-2
- Self-healing

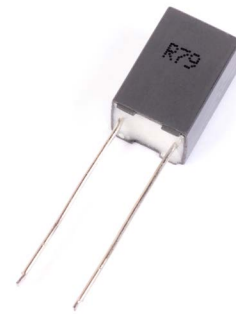

Part Number System

R79	G	C	2390	AA	40	K
Series	Rated Voltage (VDC)	Lead Spacing (mm)	Capacitance Code (pF)	Lead and Packaging Code	Internal Use	Capacitance Tolerance
Metallized Polypropylene	G = 160 I = 250 M = 400 P = 630	C = 5	Digits 2 – 4 indicate the first three digits of the capacitance value. First digit indicates the number of zeros to be added.	See Ordering Options Table	40 45	H = 2.5% J = \pm 5% K = \pm 10%

Ordering Options Table

Lead Spacing Nominal (mm)	Type of Leads and Packaging	Lead Length (mm)	Lead and Packaging Code
5	Standard Lead and Packaging Options		
	Bulk (Bag)–Short Leads	4 +1.5/-0	AA
	Ammo Pack	$H_0=18.5 \pm 0.5$	DQ
	Other Lead and Packaging Options		
	Tape & Reel (Standard Reel)	$H_0=18.5 \pm 0.5$	CK
	Bulk (Bag)–Short Leads	10 +/- 1	JC
	Bulk (Bag)–Short Leads	4.0 +0.5/-0	JE
	Bulk (Bag)–Short Leads	3.2 +0.3/-0.2	JH
	Bulk (Bag)–Long Leads	21 +/- 1	JG
	Bulk (Bag)–Long Leads	17 +/-2	Z3
Bulk (Bag)–Long Leads	30 +5/-0	40	

Dimensions – Millimeters

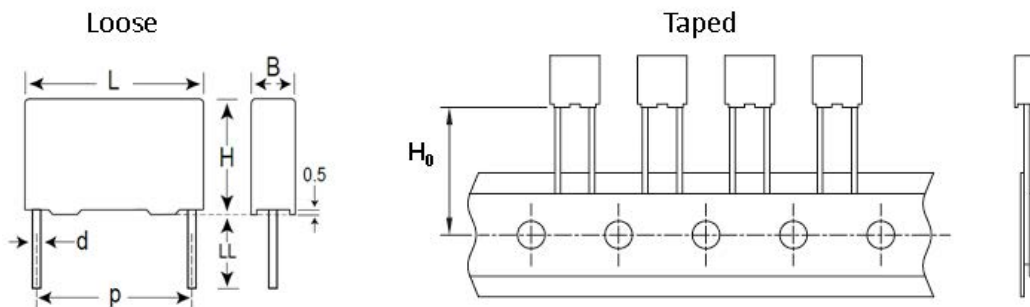

p		B		H		L		d	
Nominal	Tolerance	Nominal	Tolerance	Nominal	Tolerance	Nominal	Tolerance	Nominal	Tolerance
5.0	+/-0.4	3.5	+0.1	7.5	+0.1	7.2	+0.2	0.6	+/-0.05
5.0	+/-0.4	4.5	+0.1	9.5	+0.1	7.2	+0.3	0.6	+/-0.05
5.0	+/-0.4	5.0	+0.1	10.0	+0.1	7.2	+0.3	0.6	+/-0.05
5.0	+/-0.4	6.0	+0.1	11.0	+0.1	7.2	+0.3	0.6	+/-0.05
5.0	+/-0.4	7.2	+0.1	13.0	+0.1	7.2	+0.3	0.6	+/-0.05

Note: See Ordering Options Table for lead length (LL/H₀) options.

Performance Characteristics

Dielectric	Polypropylene film				
Plates	Metal layer deposited by evaporation under vacuum				
Winding	Non-inductive type				
Leads	Tinned wire				
Protection	Plastic case, thermosetting resin filled. Box material is solvent resistant and flame retardant according to UL94.				
Related Documents	IEC 60384-16				
Rated Voltage V_R (VDC)	160	250	400	630	
Rated Voltage V_R (VAC)	70	160	200	220	
Capacitance Range (μF)	0.039 – 0.22	0.012 – 0.15	0.0039 – 0.047	0.001 – 0.018	
Capacitance Values	E12 series (IEC 60063) measured @ 1 kHz and +20 \pm 1°C				
Capacitance Tolerance	\pm 2.5%, \pm 5%, \pm 10%				
Operating Temperature Range	-55°C to +105°C				
Rated Temperature T_R	+85°C				
Voltage Derating	Above +85°C DC and AC voltage derating is 1.25%/°C				
Climatic Category	55/105/56 IEC 60068-1				
	Average relative humidity \leq 75%				
	RH = 95% for 30 days per year				
	RH = 85% for further days limited by average value per year				
Test Voltage	1.6 x V_R VDC for 2 seconds (between terminations) @ +25°C \pm 5°C				
Capacitance Drift	Maximum 0.5% after a 2 year storage period at a temperature of +10°C to +40°C and a relative humidity of 40% to 60%				
Maximum Pulse Steepness	dV/dt according to Table 1. For peak to peak voltages lower than rated voltage ($V_{pp} < V_R$), the specified dv/dt can be multiplied by the factor V_R/V_{pp}				
Temperature Coefficient	-(200 \pm 100) ppm/°C at 1 kHz				
Self Inductance	Approximately 6 nH. Max 1 nH per 1 mm lead and capacitor length.				
Dissipation Factor $\tan\delta$	Maximum Values @ 25°C \pm 5°C				
	Frequency	$C \leq 0.1 \mu\text{F}$		$C > 1 \mu\text{F}$	
	1 kHz	0.06%		0.06%	
	10 kHz	0.10%		0.10%	
	100 kHz	0.30%		-	
Insulation Resistance	Measured @ +25°C \pm 5°C, 100 VDC 60 seconds				
	Minimum Values Between Terminals				
	All Capacitance Values				
	\geq 100,000 M Ω (\geq 500,000 M Ω) *				

* typical value

Maximum Voltage (V_{rms}) vs. Frequency (Sinusoidal Waveform/ $T_h \leq 40^\circ C$)

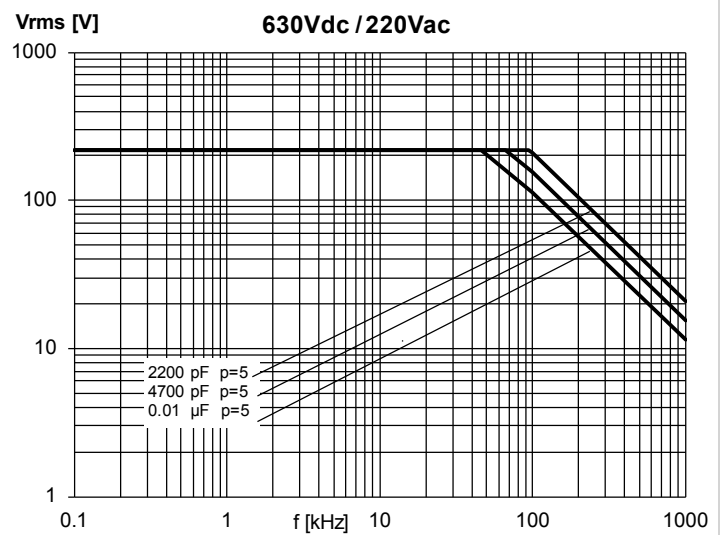
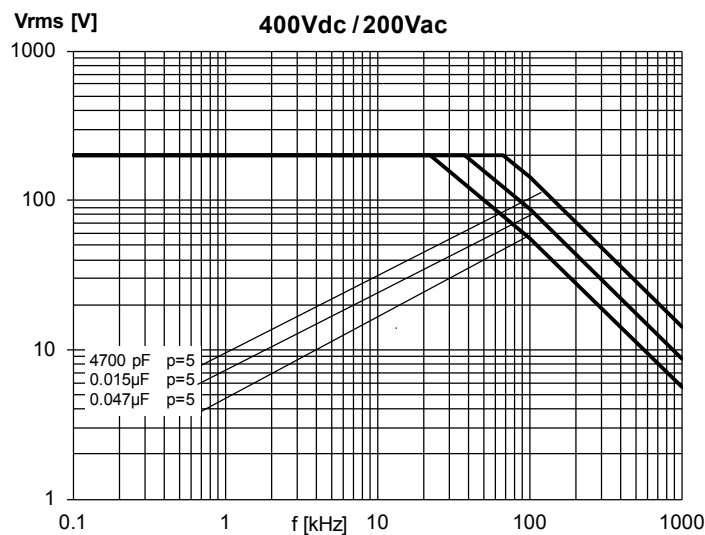
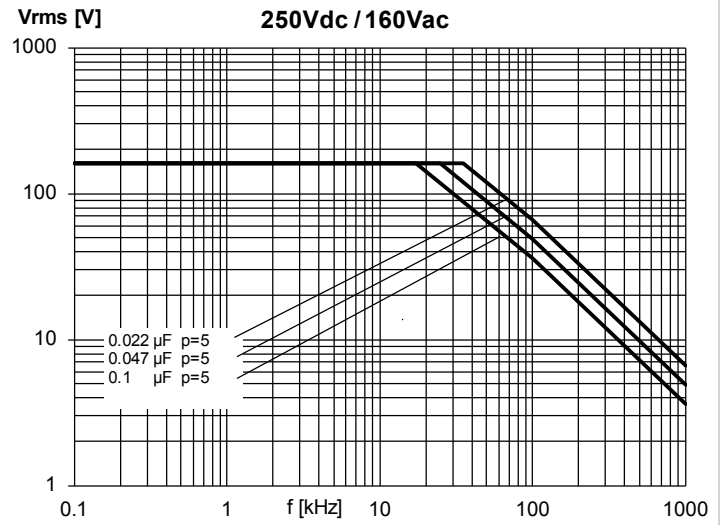
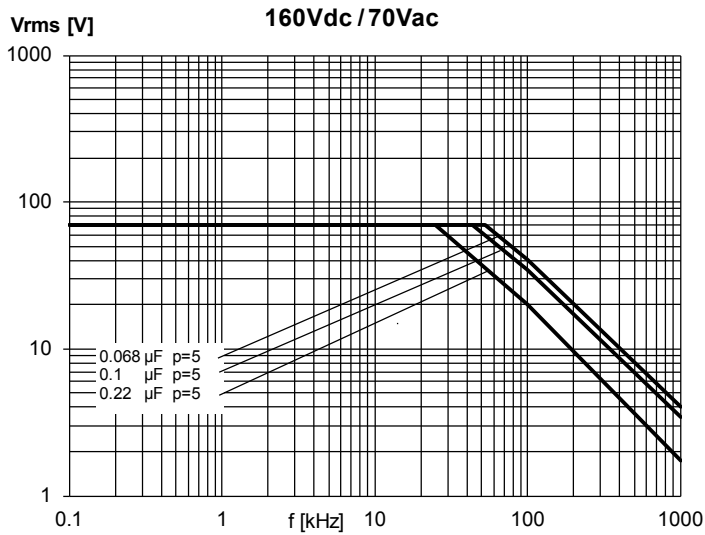

Maximum Current (I_{rms}) vs. Frequency (Sinusoidal Waveform/ $T_h \leq 40^\circ C$)

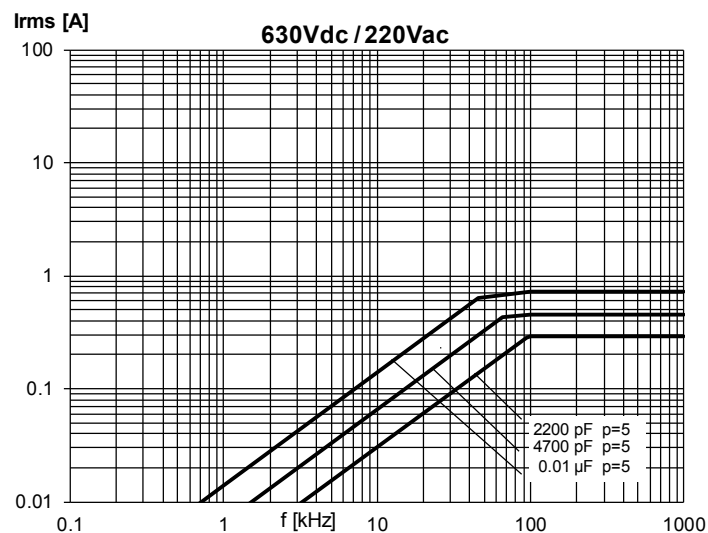
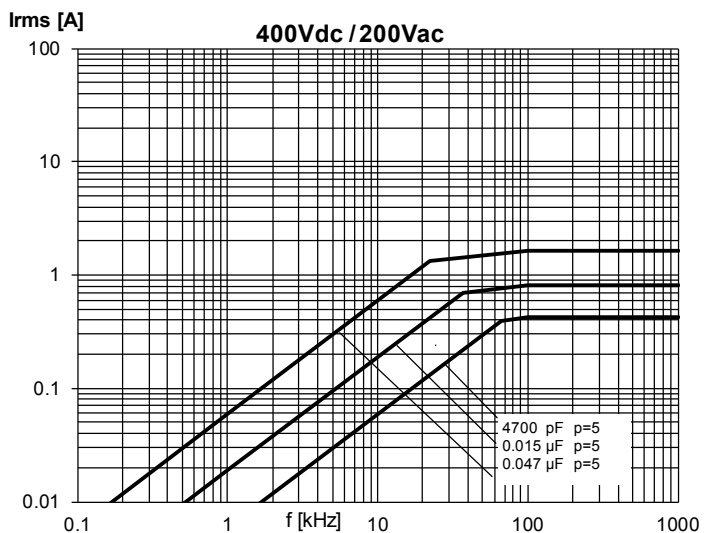
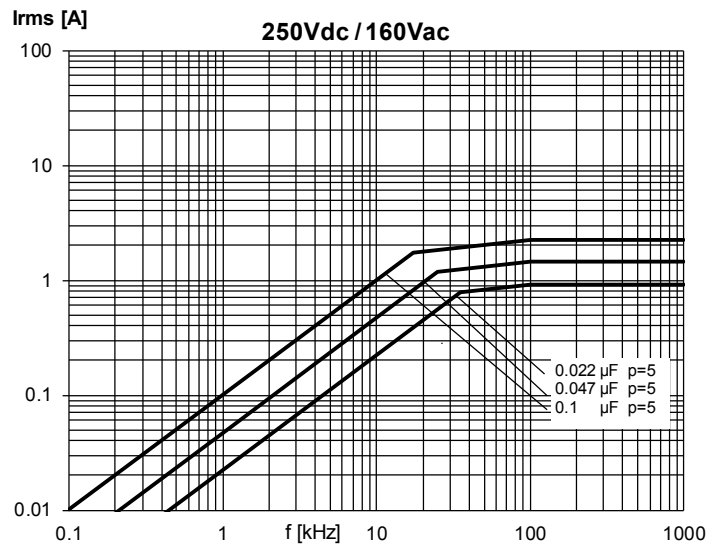
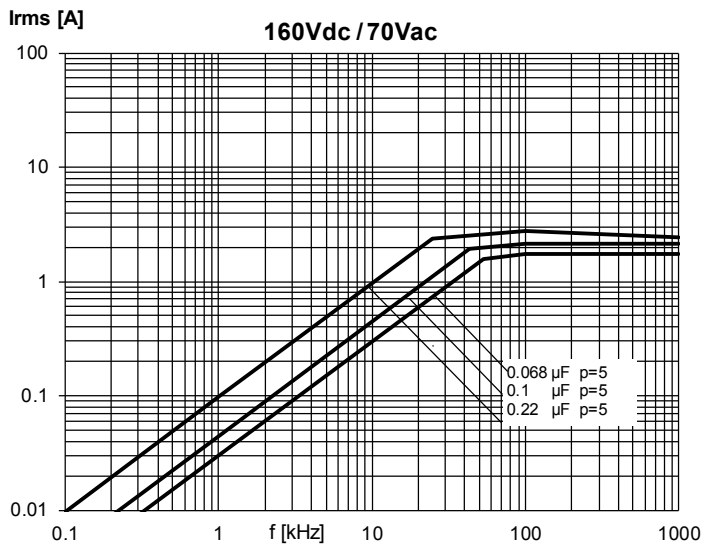

Environmental Test Data

Damp Heat, Steady State Test	Test Conditions:		Performances
	Temperature:	+40°C ± 2°C	$\Delta C/C$ ≤ 3%, $\Delta \tan\delta \leq 0.001$ @ 1 kHz IR after test ≥ 50% of initial limit
	Relative humidity (RH):	93% ± 2%	
	Test duration:	56 days	
Endurance Test	Test Conditions		Performances
	Temperature:	+85°C ± 2°C	$\Delta C/C$ ≤ 3%, $\Delta \tan\delta \leq 0.001$ @10 kHz IR after test ≥ 50% of initial limit
	Voltage applied:	1.25 x V _R (DC)	
	Test duration:	2,000 hours	
Resistance to Soldering Heat Test	Test Conditions		Performances
	Solder bath temperature:	260°C ± 5°C	$\Delta C/C$ ≤ 2%, $\Delta \tan\delta \leq 0.001$ @10 kHz for C ≤ 1μF IR after test ≥ initial limit
	Dipping time (with heat screen):	10 seconds ± 1 second	

Environmental Compliance

All KEMET pulse capacitors are RoHS Compliant.



RoHS Compliant

Table 1 – Ratings & Part Number Reference

VDC	VAC	Capacitance Value (µF)	Dimensions in mm			Lead Spacing (p)	dV/dt (V/µs)	Max K ₀ (V ² /µs)	New KEMET Part Number	Legacy Part Number
			B	H	L					
160	70	0.039	3.5	7.5	7.2	5.0	100	32,000	79GC2390(1)40(2)	R79GC2390(1)40(2)
160	70	0.047	4.5	9.5	7.2	5.0	100	32,000	79GC2470(1)40(2)	R79GC2470(1)40(2)
160	70	0.056	4.5	9.5	7.2	5.0	100	32,000	79GC2560(1)40(2)	R79GC2560(1)40(2)
160	70	0.068	4.5	9.5	7.2	5.0	100	32,000	79GC2680(1)40(2)	R79GC2680(1)40(2)
160	70	0.082	5.0	10.0	7.2	5.0	100	32,000	79GC2820(1)40(2)	R79GC2820(1)40(2)
160	70	0.10	5.0	10.0	7.2	5.0	100	32,000	79GC3100(1)40(2)	R79GC3100(1)40(2)
160	70	0.12	6.0	11.0	7.2	5.0	100	32,000	79GC3120(1)40(2)	R79GC3120(1)40(2)
160	70	0.15	6.0	11.0	7.2	5.0	100	32,000	79GC3150(1)40(2)	R79GC3150(1)40(2)
160	70	0.18	7.2	13.0	7.2	5.0	100	32,000	79GC3180(1)40(2)	R79GC3180(1)40(2)
160	70	0.22	7.2	13.0	7.2	5.0	100	32,000	79GC3220(1)40(2)	R79GC3220(1)40(2)
250	160	0.012	3.5	7.5	7.2	5.0	250	125,000	79IC2120(1)45(2)	R79IC2120(1)45(2)
250	160	0.015	3.5	7.5	7.2	5.0	250	125,000	79IC2150(1)45(2)	R79IC2150(1)45(2)
250	160	0.018	3.5	7.5	7.2	5.0	250	125,000	79IC2180(1)45(2)	R79IC2180(1)45(2)
250	160	0.022	3.5	7.5	7.2	5.0	250	125,000	79IC2220(1)45(2)	R79IC2220(1)45(2)
250	160	0.027	3.5	7.5	7.2	5.0	250	125,000	79IC2270(1)45(2)	R79IC2270(1)45(2)
250	160	0.033	3.5	7.5	7.2	5.0	250	125,000	79IC2330(1)40(2)	R79IC2330(1)40(2)
250	160	0.039	4.5	9.5	7.2	5.0	250	125,000	79IC2390(1)40(2)	R79IC2390(1)40(2)
250	160	0.047	4.5	9.5	7.2	5.0	250	125,000	79IC2470(1)40(2)	R79IC2470(1)40(2)
250	160	0.056	4.5	9.5	7.2	5.0	250	125,000	79IC2560(1)40(2)	R79IC2560(1)40(2)
250	160	0.068	5.0	10.0	7.2	5.0	250	125,000	79IC2680(1)40(2)	R79IC2680(1)40(2)
250	160	0.082	6.0	11.0	7.2	5.0	250	125,000	79IC2820(1)40(2)	R79IC2820(1)40(2)
250	160	0.10	6.0	11.0	7.2	5.0	250	125,000	79IC3100(1)40(2)	R79IC3100(1)40(2)
250	160	0.12	7.2	13.0	7.2	5.0	250	125,000	79IC3120(1)40(2)	R79IC3120(1)40(2)
250	160	0.15	7.2	13.0	7.2	5.0	250	125,000	79IC3150(1)40(2)	R79IC3150(1)40(2)
400	200	0.0039	3.5	7.5	7.2	5.0	400	320,000	79MC1390(1)40(2)	R79MC1390(1)40(2)
400	200	0.0047	3.5	7.5	7.2	5.0	400	320,000	79MC1470(1)40(2)	R79MC1470(1)40(2)
400	200	0.0056	3.5	7.5	7.2	5.0	400	320,000	79MC1560(1)40(2)	R79MC1560(1)40(2)
400	200	0.0068	3.5	7.5	7.2	5.0	400	320,000	79MC1680(1)40(2)	R79MC1680(1)40(2)
400	200	0.0082	3.5	7.5	7.2	5.0	400	320,000	79MC1820(1)40(2)	R79MC1820(1)40(2)
400	200	0.010	3.5	7.5	7.2	5.0	400	320,000	79MC2100(1)40(2)	R79MC2100(1)40(2)
400	200	0.012	4.5	9.5	7.2	5.0	400	320,000	79MC2120(1)40(2)	R79MC2120(1)40(2)
400	200	0.015	4.5	9.5	7.2	5.0	400	320,000	79MC2150(1)40(2)	R79MC2150(1)40(2)
400	200	0.018	5.0	10.0	7.2	5.0	400	320,000	79MC2180(1)40(2)	R79MC2180(1)40(2)
400	200	0.022	5.0	10.0	7.2	5.0	400	320,000	79MC2220(1)40(2)	R79MC2220(1)40(2)
400	200	0.027	6.0	11.0	7.2	5.0	400	320,000	79MC2270(1)40(2)	R79MC2270(1)40(2)
400	200	0.033	6.0	11.0	7.2	5.0	400	320,000	79MC2330(1)40(2)	R79MC2330(1)40(2)
400	200	0.039	7.2	13.0	7.2	5.0	400	320,000	79MC2390(1)40(2)	R79MC2390(1)40(2)
400	200	0.047	7.2	13.0	7.2	5.0	400	320,000	79MC2470(1)40(2)	R79MC2470(1)40(2)
630	220	0.0010	3.5	7.5	7.2	5.0	500	630,000	79PC1100(1)40(2)	R79PC1100(1)40(2)
630	220	0.0012	3.5	7.5	7.2	5.0	500	630,000	79PC1120(1)40(2)	R79PC1120(1)40(2)
630	220	0.0015	3.5	7.5	7.2	5.0	500	630,000	79PC1150(1)40(2)	R79PC1150(1)40(2)
630	220	0.0018	3.5	7.5	7.2	5.0	500	630,000	79PC1180(1)40(2)	R79PC1180(1)40(2)
630	220	0.0022	3.5	7.5	7.2	5.0	500	630,000	79PC1220(1)40(2)	R79PC1220(1)40(2)
630	220	0.0027	3.5	7.5	7.2	5.0	500	630,000	79PC1270(1)40(2)	R79PC1270(1)40(2)
630	220	0.0033	3.5	7.5	7.2	5.0	500	630,000	79PC1330(1)40(2)	R79PC1330(1)40(2)
630	220	0.0039	4.5	9.5	7.2	5.0	600	756,000	79PC1390(1)40(2)	R79PC1390(1)40(2)
630	220	0.0047	4.5	9.5	7.2	5.0	600	756,000	79PC1470(1)40(2)	R79PC1470(1)40(2)
630	220	0.006	4.5	9.5	7.2	5.0	600	756,000	79PC1560(1)40(2)	R79PC1560(1)40(2)
630	220	0.007	5.0	10.0	7.2	5.0	600	756,000	79PC1680(1)40(2)	R79PC1680(1)40(2)
630	220	0.008	5.0	10.0	7.2	5.0	600	756,000	79PC1820(1)40(2)	R79PC1820(1)40(2)
630	220	0.010	6.0	11.0	7.2	5.0	600	756,000	79PC2100(1)40(2)	R79PC2100(1)40(2)
630	220	0.012	6.0	11.0	7.2	5.0	600	756,000	79PC2120(1)40(2)	R79PC2120(1)40(2)
630	220	0.015	7.2	13.0	7.2	5.0	600	756,000	79PC2150(1)40(2)	R79PC2150(1)40(2)
630	220	0.018	7.2	13.0	7.2	5.0	600	756,000	79PC2180(1)40(2)	R79PC2180(1)40(2)
VDC	VAC	Capacitance Value (µF)	B (mm)	H (mm)	L (mm)	Lead Spacing (p)	dV/dt (V/µs)	Max K ₀ (V ² /µs)	New KEMET Part Number	Legacy Part Number

(1) Insert lead and packaging code. See Ordering Options Table for available options.

(2) J = 5%, K = 10%, M = 20%

Soldering Process

The implementation of the RoHS directive has resulted in the selection of SnAgCu (SAC) alloys or SnCu alloys as primary solder. This has increased the liquidus temperature from that of 183°C for SnPb eutectic alloy to 217 – 221°C for the new alloys. As a result, the heat stress to the components, even in wave soldering, has increased considerably due to higher pre-heat and wave temperatures. Polypropylene capacitors are especially sensitive to heat (the melting point of polypropylene is 160 – 170°C). Wave soldering can be destructive, especially for mechanically small polypropylene capacitors (with lead spacing of 5 mm to 15 mm), and great care has to be taken during soldering. The recommended solder profiles from KEMET should be used. Please consult KEMET with any questions. In general, the wave soldering curve from IEC Publication 61760-1 Edition 2 serves as a solid guideline for successful soldering. Please see Figure 1.

Reflow soldering is not recommended for through-hole film capacitors. Exposing capacitors to a soldering profile in excess of the above the recommended limits may result to degradation or permanent damage to the capacitors.

Do not place the polypropylene capacitor through an adhesive curing oven to cure resin for surface mount components. Insert through-hole parts after the curing of surface mount parts. Consult KEMET to discuss the actual temperature profile in the oven, if through-hole components must pass through the adhesive curing process. A maximum two soldering cycles is recommended. Please allow time for the capacitor surface temperature to return to a normal temperature before the second soldering cycle.

Figure 1

Dielectric Film Material	Maximum Preheat Temperature			Maximum Peak Soldering Temperature	
	Capacitor Lead Spacing <10 mm	Capacitor Lead Spacing = 15 mm	Capacitor Lead Spacing >15 mm	Capacitor Lead Spacing <15 mm	Capacitor Lead Spacing >15 mm
Polyester	130°C	130°C	130°C	270°C	270°C
Polypropylene	100°C	110°C	130°C	260°C	270°C
Polyphenylene Sulphide	150°C	150°C	160°C	270°C	270°C

Wave Soldering Recommendations

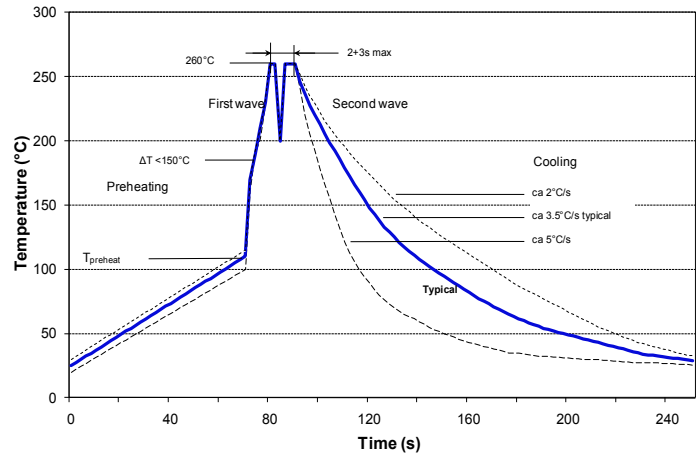

Manual Soldering Recommendations

Following is the recommendation for manual soldering with a soldering iron.

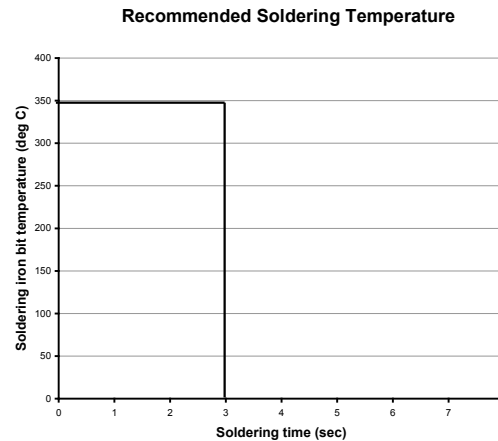

The soldering iron tip temperature should be set at 350°C (+10°C maximum) with the soldering duration not to exceed more than 3 seconds.

Soldering Process cont'd

Selective Soldering Recommendations

Selective dip soldering is a variation of reflow soldering. In this method, the printed circuit board with through-hole components to be soldered is preheated and transported over the solder bath as in normal flow soldering without touching the solder. When the board is over the bath, it is stopped and pre-designed solder pots are lifted from the bath with molten solder only at the places of the selected components, and pressed against the lower surface of the board to solder the components.

The temperature profile for selective soldering is similar to the double wave flow soldering outlined in this document, **however, instead of two baths, there is only one bath with a time from 3 to 10 seconds.** In selective soldering, the risk of overheating is greater than in double wave flow soldering, and great care must be taken so that the parts are not overheated.

Construction

Winding scheme

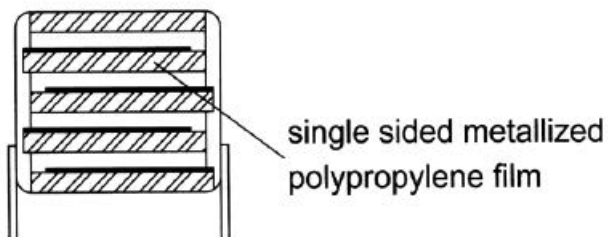

Marking

- KEMET's logo
- Series
- Dielectric code (MKP)
- Capacitance
- Capacitance tolerance
- Rated DC voltage

Packaging Quantities

Lead Spacing	Thickness (mm)	Height (mm)	Length (mm)	Bulk Short Leads	Bulk Long Leads	Standard Reel Ø 355 mm	Large Reel Ø 500 mm	Ammo Taped
5	3.5	7.5	7.2	2,000	3,000	1,800		2,500
	4.5	9.5	7.2	1,500	2,000	1,400		1,900
	5.0	10	7.2	1,000	1,500	1,200		1,700
	6.0	11	7.2	2,000	1,000	1,000		1,400
	7.2	13	7.2	1,500	750	800		1,150

Lead Taping & Packaging (IEC 60286–2)

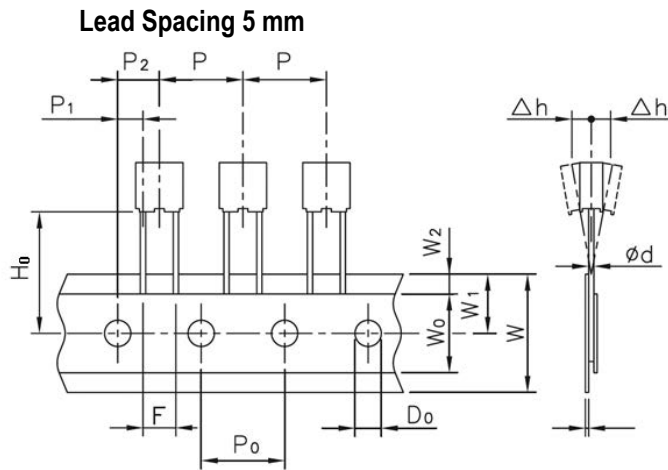

Taping Specification

Description	Symbol	Dimensions (mm)	
		Lead Spacing	Tolerance
		5	
Lead wire diameter	d	0.5	±0.05
Taping lead space	P	12.7	±1
Feed hole lead space	P ₀	12.7	±0.2**
Centering of the lead wire	P ₁	3.85	±0.7
Centering of the body	P ₂	6.35	±1.3
Lead spacing	F	5	+0.6/-0.1
Component alignment	Dh	0	±2
Height of component from tape center	H ₀ *	18.5	±0.5
Carrier tape width	W	18	+1/-0.5
Hold down tape width	W ₀	6	Minimum
Hole position	W ₁	9	±0.5
Hold down tape position	W ₂	3	Maximum
Feed hole diameter	D ₀	4	±0.2
Tape thickness	t	0.7	±0.2

*H₀ = 16.5 mm is available upon request.

**Maximum 1 mm on 20 lead spacing.

Lead Taping & Packaging (IEC 60286–2) cont'd

Ammo Specifications

Dimensions (mm)		
H	W	T
360*	340	59

* Lower dimension available upon request (Maximum 295 mm)

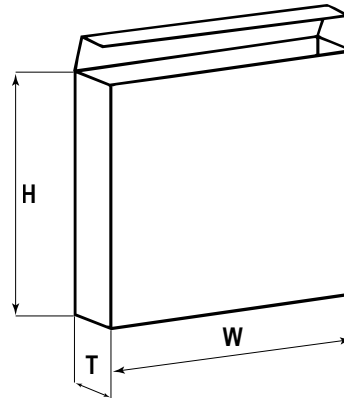

Reel Specifications

Dimensions (mm)		
D	H	W
355	30	55 Maximum

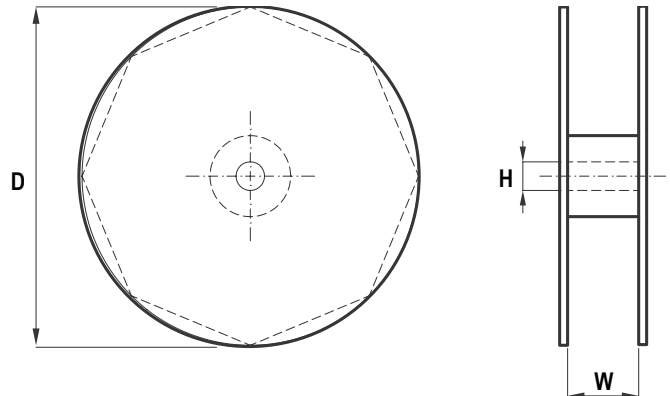

Manufacturing Date Code (IEC–60062)

Y = Year, Z = Month			
Year	Code	Month	Code
2000	M	January	1
2001	N	February	2
2002	P	March	3
2003	R	April	4
2004	S	May	5
2005	T	June	6
2006	U	July	7
2007	V	August	8
2008	W	September	9
2009	X	October	0
2010	A	November	N
2011	B	December	D
2012	C		
2013	D		
2014	E		
2015	F		
2016	H		
2017	J		
2018	K		
2019	L		
2020	M		

KEMET Corporation World Headquarters

2835 KEMET Way
Simpsonville, SC 29681

Mailing Address:
P.O. Box 5928
Greenville, SC 29606

www.kemet.com
Tel: 864-963-6300
Fax: 864-963-6521

Corporate Offices
Fort Lauderdale, FL
Tel: 954-766-2800

North America

Southeast
Lake Mary, FL
Tel: 407-855-8886

Northeast
Wilmington, MA
Tel: 978-658-1663

Central
Novi, MI
Tel: 248-306-9353

West
Milpitas, CA
Tel: 408-433-9950

Mexico
Guadalajara, Jalisco
Tel: 52-33-3123-2141

Europe

Southern Europe
Paris, France
Tel: 33-1-4646-1006

Sasso Marconi, Italy
Tel: 39-051-939111

Central Europe
Landsberg, Germany
Tel: 49-8191-3350800

Kamen, Germany
Tel: 49-2307-438110

Northern Europe
Bishop's Stortford, United Kingdom
Tel: 44-1279-460122

Espoo, Finland
Tel: 358-9-5406-5000

Asia

Northeast Asia
Hong Kong
Tel: 852-2305-1168

Shenzhen, China
Tel: 86-755-2518-1306

Beijing, China
Tel: 86-10-5829-1711

Shanghai, China
Tel: 86-21-6447-0707

Taipei, Taiwan
Tel: 886-2-27528585

Southeast Asia
Singapore
Tel: 65-6586-1900

Penang, Malaysia
Tel: 60-4-6430200

Bangalore, India
Tel: 91-806-53-76817

Note: KEMET reserves the right to modify minor details of internal and external construction at any time in the interest of product improvement. KEMET does not assume any responsibility for infringement that might result from the use of KEMET Capacitors in potential circuit designs. KEMET is a registered trademark of KEMET Electronics Corporation.

Disclaimer

All product specifications, statements, information and data (collectively, the "Information") in this datasheet are subject to change. The customer is responsible for checking and verifying the extent to which the Information contained in this publication is applicable to an order at the time the order is placed.

All Information given herein is believed to be accurate and reliable, but it is presented without guarantee, warranty, or responsibility of any kind, expressed or implied.

Statements of suitability for certain applications are based on KEMET Electronics Corporation's ("KEMET") knowledge of typical operating conditions for such applications, but are not intended to constitute – and KEMET specifically disclaims – any warranty concerning suitability for a specific customer application or use. The Information is intended for use only by customers who have the requisite experience and capability to determine the correct products for their application. Any technical advice inferred from this Information or otherwise provided by KEMET with reference to the use of KEMET's products is given gratis, and KEMET assumes no obligation or liability for the advice given or results obtained.

Although KEMET designs and manufactures its products to the most stringent quality and safety standards, given the current state of the art, isolated component failures may still occur. Accordingly, customer applications which require a high degree of reliability or safety should employ suitable designs or other safeguards (such as installation of protective circuitry or redundancies) in order to ensure that the failure of an electrical component does not result in a risk of personal injury or property damage.

Although all product-related warnings, cautions and notes must be observed, the customer should not assume that all safety measures are indicated or that other measures may not be required.

X-ON Electronics

Largest Supplier of Electrical and Electronic Components

Click to view similar products for [Film Capacitors](#) category:

Click to view products by [Kemet](#) manufacturer:

Other Similar products are found below :

[F450KG153J250ALH0J](#) [750-1018](#) [FKP1-1000160010P15](#) [FKP1-1500160010P15](#) [82EC1100DQ50K](#) [MMWAF150KME](#)

[PFR5101J100J11L16.5TA18](#) [PME261JB5220KR19T0](#) [A521HH333M035C](#) [A561ED221M450A](#) [QXJ2E474KTPT](#) [QXL2B333KTPT](#)

[QXM2G104K](#) [DMT2P22](#) [EEC2G505HQA406](#) [B32520C6332K000](#) [B32522C6104K000](#) [B32676E6755K](#) [C3B2AD44400B20K](#)

[SCD105K122A3-22](#) [2N3155](#) [F601BL225K063CL60A](#) [FKP1-2202KV5P15](#) [FKS3-680040010P10](#) [445450-1](#) [B32523Q0475K000](#)

[46KR415050M1K](#) [4BSNBX4100ZBFJ](#) [4DCNAQ4450ZA0J](#) [MKP383510063JKP2T0](#) [MKT 1813-368-015](#) [MKT182022263473](#) [4055292001](#)

[WMC08P22](#) [WMF1S15](#) [WMF4S68](#) [EEC2E106HQA405](#) [EEC2G805HQA415](#) [82DC3100DQ50J](#) [82EC2150DQ50K](#) [WMF4D68](#) [WMF1D68](#)

[B25620B118K883](#) [ECW-F2105JAC](#) [B25620B158K883](#) [66MD2100CK7AK](#) [A521HH471M450C](#) [97F8038](#) [NRM-S225K250F](#)

[730P205X9400](#)