

High Voltage Regulator HT71XX

■ Features

- Low power consumption
- Low voltage drop
- Low temperature coefficient
- High input voltage (up to 24V)

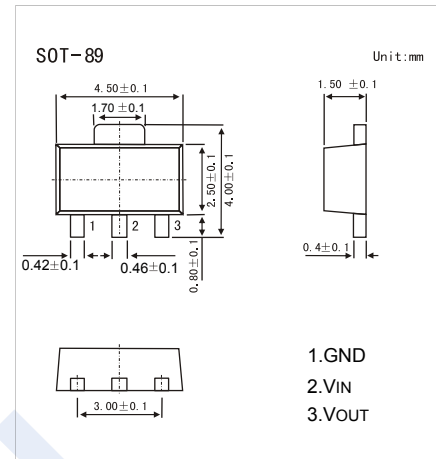
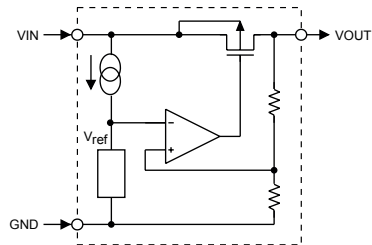

Selection Table

Part No.	Output Voltage	Tolerance
HT7130	3.0V	± 5%
HT7133	3.3V	± 5%
HT7136	3.6V	± 5%
HT7144	4.4V	± 5%
HT7150	5.0V	± 5%

■ Absolute Maximum Ratings Ta = 25°C

Parameter	Symbol	Rating	Unit
Supply Voltage		-0.3 to 28	V
Power Consumption	P _c	200	mW
Junction Temperature	T _J	125	°C
Operating Temperature	T _{op}	0 to 70	
Storage Temperature range	T _{stg}	-50 to 125	

High Voltage Regulator

HT71XX

■ Electrical Characteristics Ta = 25°C

HT7130, +3.0V output type

Parameter	Symbol	Test Conditions		Min	Typ	Max	Unit
		V _{IN}	Conditions				
Output Voltage Tolerance	V _{OUT}	5V	I _{OUT} =10mA	2.85	3	3.15	V
Input Voltage	V _{IN}	-				24	
Load Regulation	ΔV _{OUT}	5V	1mA ≤ I _{OUT} ≤ 20mA		60	100	mV
Voltage Drop	V _{DIF}	-	I _{OUT} =1mA		100		
Output Current	I _{OUT}	5V		20	30		mA
Current Consumption	I _{SS}	5V	No load		4	6	μA
Line Regulation	$\frac{\Delta V_{OUT}}{\Delta V_{IN} \times V_{OUT}}$	-	4V ≤ V _{IN} ≤ 24V I _{OUT} =1mA		0.2		%/V
Temperature Coefficient	$\frac{\Delta V_{OUT}}{\Delta T_a}$	5V	I _{OUT} =10mA 0 °C < T _a < 70 °C		±0.45		mV/°C

HT7133, +3.3V output type

Parameter	Symbol	Test Conditions		Min	Typ	Max	Unit
		V _{IN}	Conditions				
Output Voltage Tolerance	V _{OUT}	5.5V	I _{OUT} =10mA	3.135	3.3	3.465	V
Input Voltage	V _{IN}	-				24	
Load Regulation	ΔV _{OUT}	5.5V	1mA ≤ I _{OUT} ≤ 30mA		60	100	mV
Voltage Drop	V _{DIF}	-	I _{OUT} =1mA		100		
Output Current	I _{OUT}	5.5V		20	30		mA
Current Consumption	I _{SS}	5.5V	No load		4	6	μA
Line Regulation	$\frac{\Delta V_{OUT}}{\Delta V_{IN} \times V_{OUT}}$	-	4.5V ≤ V _{IN} ≤ 24V I _{OUT} =1mA		0.2		%/V
Temperature Coefficient	$\frac{\Delta V_{OUT}}{\Delta T_a}$	5.5V	I _{OUT} =10mA 0 °C < T _a < 70 °C		±0.5		mV/°C

HT7136, +3.6V output type

Parameter	Symbol	Test Conditions		Min	Typ	Max	Unit
		V _{IN}	Conditions				
Output Voltage Tolerance	V _{OUT}	5.6V	I _{OUT} =10mA	3.42	3.6	3.78	V
Input Voltage	V _{IN}	-				24	
Load Regulation	ΔV _{OUT}	5.6V	1mA ≤ I _{OUT} ≤ 30mA		60	100	mV
Voltage Drop	V _{DIF}	-	I _{OUT} =1mA		60		
Output Current	I _{OUT}	5.6V		20	30		mA
Current Consumption	I _{SS}	5.6V	No load		3	7	μA
Line Regulation	$\frac{\Delta V_{OUT}}{\Delta V_{IN} \times V_{OUT}}$	-	4.6V ≤ V _{IN} ≤ 12V I _{OUT} =1mA		0.2		%/V
Temperature Coefficient	$\frac{\Delta V_{OUT}}{\Delta T_a}$	5.6V	I _{OUT} =10mA 0 °C < T _a < 70 °C		±0.6		mV/°C

High Voltage Regulator

HT71XX

■ Electrical Characteristics Ta = 25°C

HT7144, +4.4V output type

Parameter	Symbol	Test Conditions		Min	Typ	Max	Unit
		V _{IN}	Conditions				
Output Voltage Tolerance	V _{OUT}	6.4V	I _{OUT} =10mA	4.18	4.4	4.62	V
Input Voltage	V _{IN}	-				24	
Load Regulation	ΔV _{OUT}	6.4V	1mA ≤ I _{OUT} ≤ 30mA		60	100	mV
Voltage Drop	V _{DIF}	-	I _{OUT} =1mA		100		
Output Current	I _{OUT}	6.4V		20	30		mA
Current Consumption	I _{SS}	6.4V	No load		4	7.5	μA
Line Regulation	$\frac{\Delta V_{OUT}}{\Delta V_{IN} \times V_{OUT}}$	-	5.4V ≤ V _{IN} ≤ 24V I _{OUT} =1mA		0.2		%/V
Temperature Coefficient	$\frac{\Delta V_{OUT}}{\Delta T_a}$	6.4V	I _{OUT} =10mA 0 °C < T _a < 70 °C		±0.7		mV/°C

HT7150, +5.0V output type

Parameter	Symbol	Test Conditions		Min	Typ	Max	Unit
		V _{IN}	Conditions				
Output Voltage Tolerance	V _{OUT}	7V	I _{OUT} =10mA	4.75	5	5.25	V
Input Voltage	V _{IN}	-				24	
Load Regulation	ΔV _{OUT}	7V	1mA ≤ I _{OUT} ≤ 30mA		60	100	mV
Voltage Drop	V _{DIF}	-	I _{OUT} =1mA		100		
Output Current	I _{OUT}	7V		20	30		mA
Current Consumption	I _{SS}	7V	No load		5	9	μA
Line Regulation	$\frac{\Delta V_{OUT}}{\Delta V_{IN} \times V_{OUT}}$	-	6V ≤ V _{IN} ≤ 24V I _{OUT} =1mA		0.2		%/V
Temperature Coefficient	$\frac{\Delta V_{OUT}}{\Delta T_a}$	7V	I _{OUT} =10mA 0 °C < T _a < 70 °C		±0.75		mV/°C

■ Application Circuits

Basic circuits

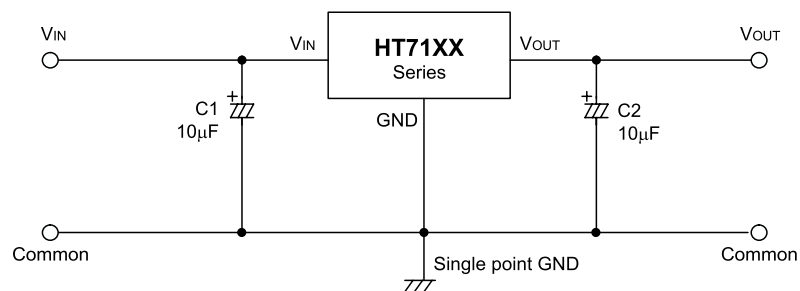

High Voltage Regulator

HT71XX

Application Circuits

High output current positive voltage regulator

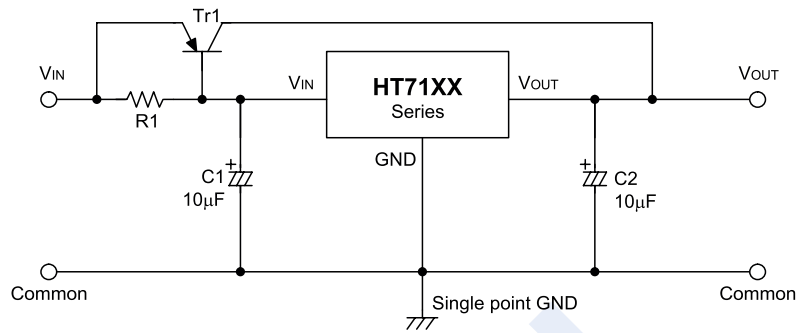

Short-Circuit protection by Tr1

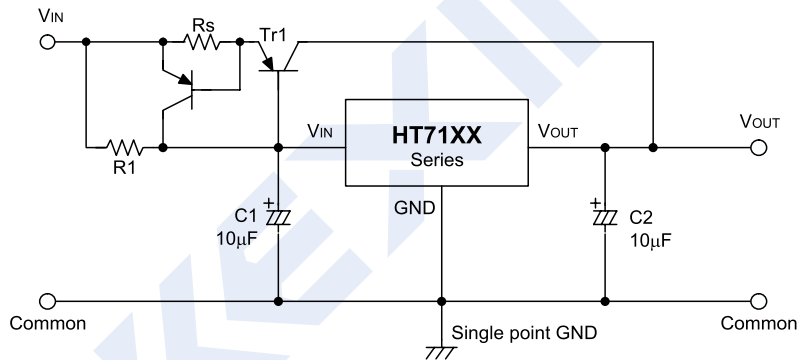

Circuit for increasing output voltage

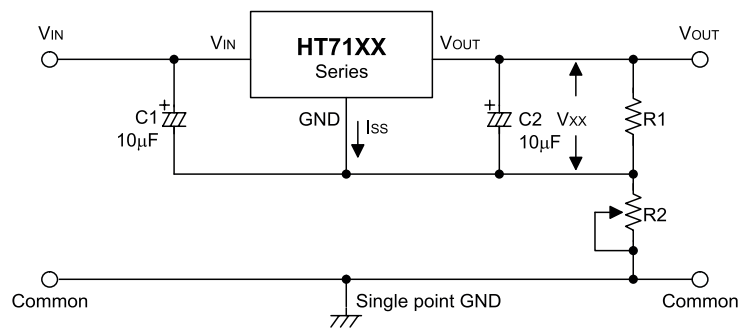

$$V_{OUT} = V_{xx} \left(1 + \frac{R2}{R1}\right) + I_{ss} R2$$

High Voltage Regulator HT71XX

■ Application Circuits

Circuit for increasing output voltage

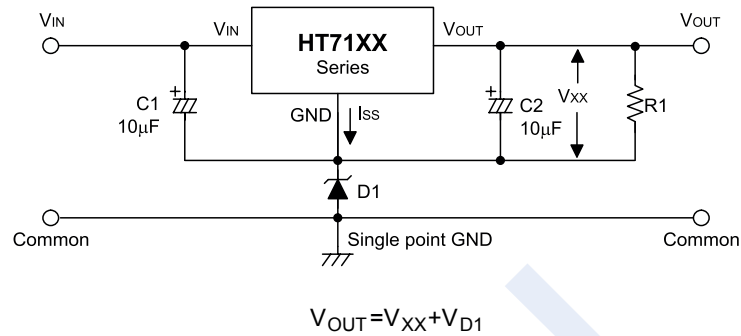

Constant current regulator

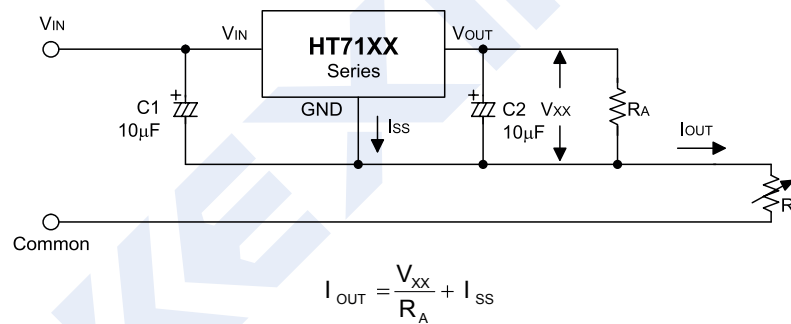

Dual supply

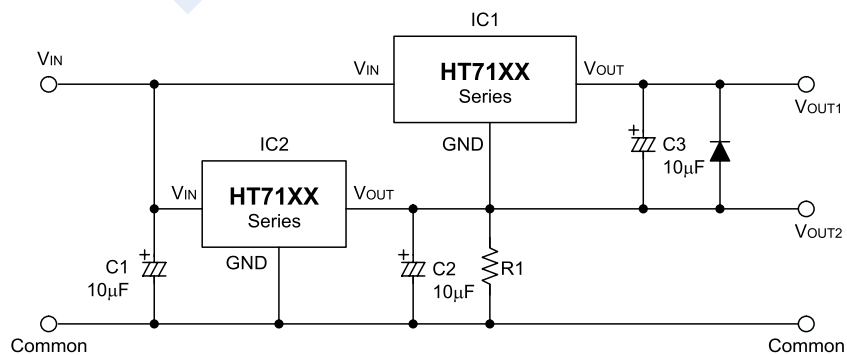

X-ON Electronics

Largest Supplier of Electrical and Electronic Components

Click to view similar products for [LDO Voltage Regulators](#) category:

Click to view products by [KEXIN](#) manufacturer:

Other Similar products are found below :

[M38D29FFHP#U1](#) [702103A](#) [717726C](#) [742457H](#) [MP20051DN-LF-Z](#) [R5F111PGGFB#30](#) [AP7363-SP-13](#) [NCP103AMX285TCG](#)
[NCV8664CST33T3G](#) [NCV8752AMX28TCG](#) [L9454](#) [AP7362-HA-7](#) [LX13043CLD](#) [TCR3DF185,LM\(CT](#) [TCR3DF24,LM\(CT](#)
[TCR3DF285,LM\(CT](#) [TCR3DF31,LM\(CT](#) [TCR3DF45,LM\(CT](#) [TLF4949EJ](#) [L9708](#) [L970813TR](#) [030014BB](#) [059985X](#) [EAN61387601](#)
[EAN61573601](#) [NCP121AMX173TCG](#) [NCP4687DH15T1G](#) [NCV8703MX30TCG](#) [701326R](#) [702087BB](#) [755078E](#) [TCR2EN28,LF\(S](#)
[LM1117DT-1.8/NO](#) [LT1086CM#TRPBF](#) [AZ1085S2-1.5TRE1](#) [MAX15101EWL+T](#) [NCV8170AXV250T2G](#) [SCD337BTG](#)
[TCR3DF27,LM\(CT](#) [TCR3DF19,LM\(CT](#) [TCR3DF125,LM\(CT](#) [TCR2EN18,LF\(S](#) [MAX15103EWL+T](#) [TS2937CZ-5.0 C0](#) [MAX8878EUK30-](#)
[T](#) [MAX663CPA](#) [NCV4269CPD50R2G](#) [NCV8716MT30TBG](#) [AZ1117IH-1.2TRG1](#) [MP2013GQ-P](#)