

GENERAL DESCRIPTION

The HV8549 is a 2-channel low saturation voltage forward/reverse motor driver IC. It is optimal for motor drive in 12V and 24V system products and can drive a stepper motor in Full-step.

The output driver block of each H-bridge consists of N-channel power MOSFETs configured as a H-bridge to drive the motor windings. Each H-bridge includes circuitry to regulate or limit the winding current.

Internal shutdown functions are provided for under-voltage lockout, and over temperature. A low-power sleep mode is also provided.

The HV8549 is available in a compact SOIC-10 package.

FEATURES

- DMOS output transistor adoption (upper and lower total $R_{ds(on)} = 0.65 \Omega$ Typ.).
- $V_{CC} \text{ Max} = 28V$, $I_O \text{ Max} = 1.2A$, $I_O \text{ RMS} = 0.8A$.
- 4V to 28V operating supply voltage range (The control system power supply is unnecessary.).
- The compact package (SOIC-10) is adopted.
- Current consumption 0 when standby mode.

TYPICAL APPLICATIONS

- Stage Lighting
- Refrigerator
- Flatbed Scanner, Document Scanner
- POS Printer, Label Printer
- PoE Point of Sales Terminal
- Clothes Dryer
- Vacuum Cleaner
- Time Recorder

TYPICAL APPLICATION CIRCUIT

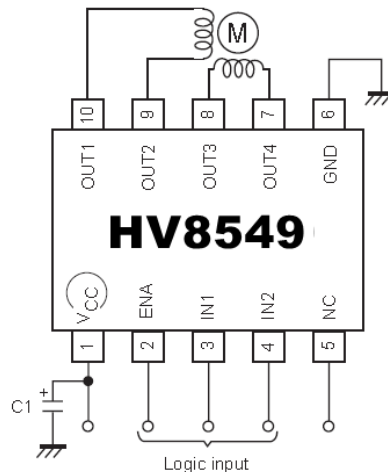
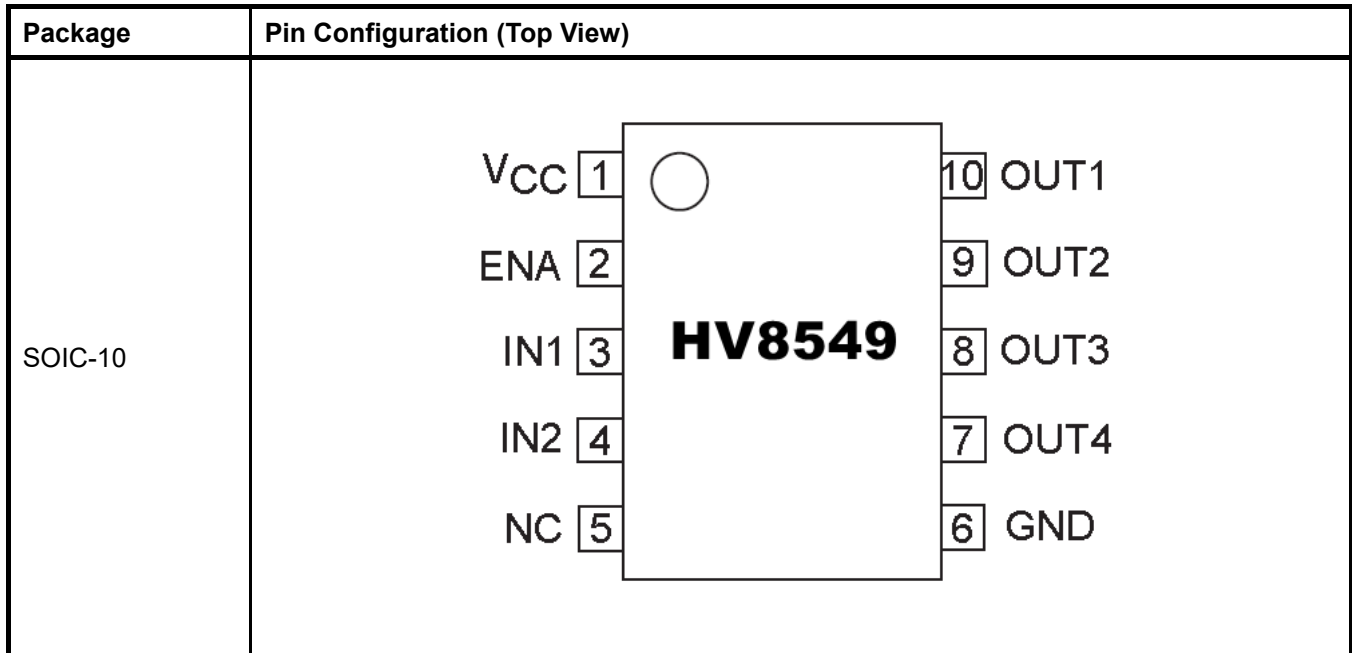

Figure 1 Typical Application Circuit

PIN CONFIGURATION



PIN DESCRIPTION

No.	Pin	Description
1	V _{CC}	Power-supply voltage pin. A 10-uF (minimum) ceramic bypass capacitor to GND is recommended.
2	ENA	Motor drive control enable pin. "0" stand-by current when ENA=L. Output is corresponding to input control logic when ENA=H.
3	IN1	Logic input pin of OUT1 and OUT2. Internal pull-down.
4	IN2	Logic input pin of OUT3 and OUT4. Internal pull-down.
5	NC	No connection.
6	GND	Device ground.
7	OUT4	Driving output pin. Motor coil is connected between terminal OUT3 (pin8).
8	OUT3	Driving output pin. Motor coil is connected between terminal OUT4 (pin7).
9	OUT2	Driving output pin. Motor coil is connected between terminal OUT1 (pin10).
10	OUT1	Driving output pin. Motor coil is connected between terminal OUT2 (pin9).

ORDERING INFORMATION

Industrial Range: -40°C to +125°C

Order Part No.	Package	QTY
HV8549MC-AH	SOIC-10, Pb-Free	4000/Reel
HV8549CC-13GTR	SOIC-10, Pb-Free	4000/Reel
HV8549CC-GT	SOIC-10, Pb-Free	100/Tube

FUNCTIONAL BLOCK DIAGRAM

Figure 2 Stepper Motor Drive

ABSOLUTE MAXIMUM RATINGS

Symbol	Definition		Min.	Max.	Units
V _{CC} Max	Maximum power supply voltage (V _{CC})		-0.3	+30	V
V _{OUT}	Output voltage (OUT1, OUT2, OUT3, OUT4)		-0.3	+30	
V _{IN}	Input voltage (EN, IN1, IN2)		-0.3	+6	
I _{GND}	Maximum GND pin sink/source current		---	+1.2	A
P _D	Package power dissipation @ T _A ≤ +25°C	SOIC-10	---	1.0	W
R _{thJA}	Thermal resistance, junction to ambient	SOIC-10	---	80	°C/W
T _J	Junction temperature		---	150	°C
T _S	Storage temperature		-55	150	
T _L	Lead temperature (soldering, 10 seconds)		---	300	

Note:

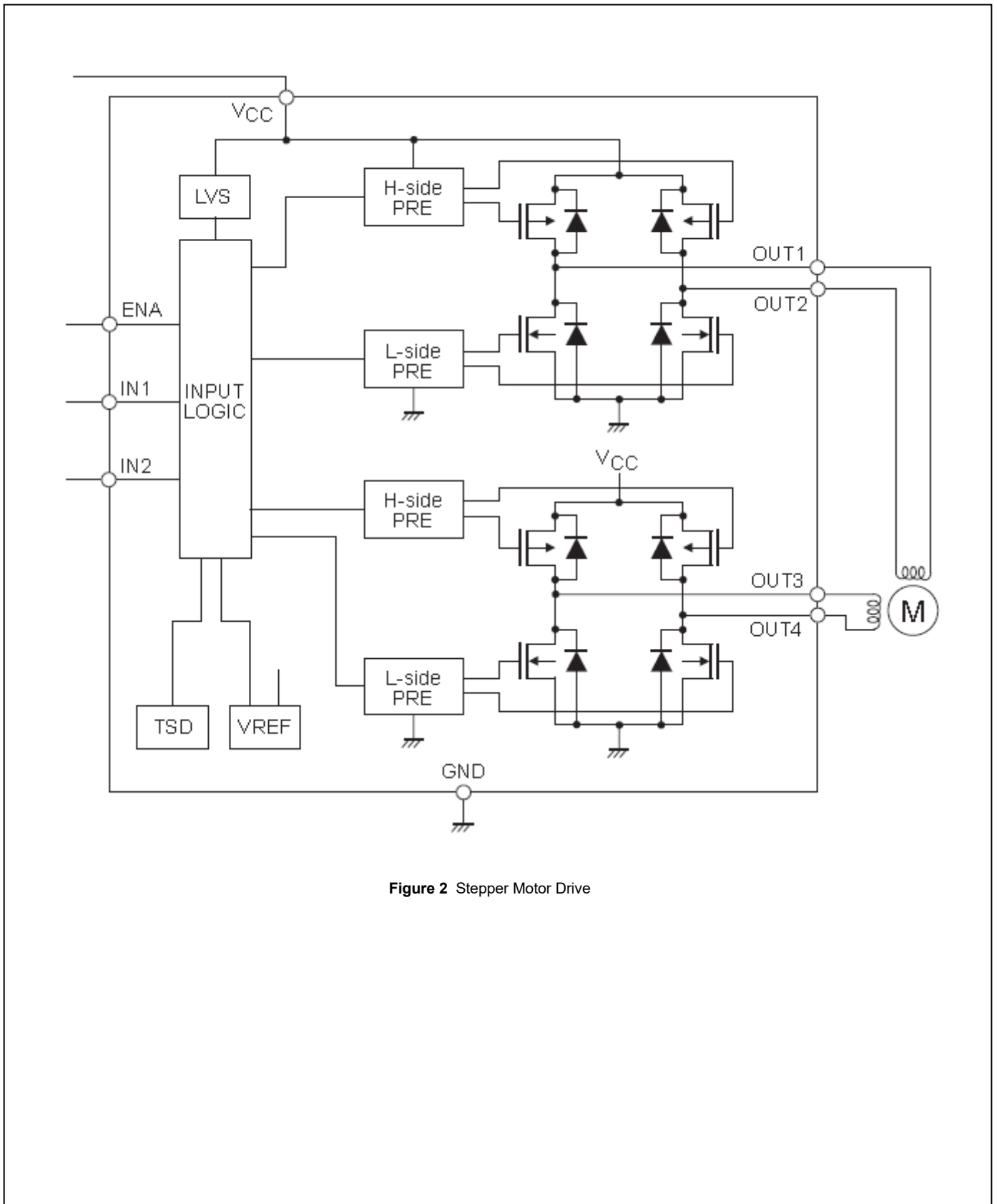
Absolute maximum ratings indicate sustained limits beyond which damage to the device may occur. All voltage parameters are absolute voltages referenced to COM. The thermal resistance and power dissipation ratings are measured under board mounted and still air conditions.

RECOMMENDED OPERATION CONDITIONS

Symbol	Definition	Min.	Max.	Units
V _{CC}	Power supply voltage (V _{CC})	4.0	28	V
V _{IH}	Logic "1" input voltage (EN, IN1, IN2)	1.8	5.5	
V _{IL}	Logic "0" input voltage (EN, IN1, IN2)	-0.3	+0.7	
V _{LO}	Low-side output voltage	0	V _{CC}	
T _A	Ambient temperature	-40	125	°C

Note:

The input/output logic timing diagram is shown in Fig. 1. For proper operation the device should be used within the recommended conditions. The V_S offset rating is tested with all supplies biased at a 15 V differential.

DYNAMIC ELECTRICAL CHARACTERISTICS

$V_{CC} = 12\text{ V}$ and $T_A = 25^\circ\text{C}$ unless otherwise specified.

Symbol	Parameter	Condition	Min.	Typ.	Max.	Unit
t_{on}	Turn-on propagation delay	$V_{CC} = 12 / 24\text{ V}$	170	200	230	ns
t_{off}	Turn-off propagation delay	$V_{CC} = 12 / 24\text{ V}$	80	100	120	
t_r	Turn-on rise time	$V_{CC} = 12 / 24\text{ V}$, 16Ω to GND, 10% to 90% V_{CC}	160	200	240	
t_f	Turn-off fall time	$V_{CC} = 12 / 24\text{ V}$, 16Ω to GND, 90% to 10% V_{CC}	220	260	300	
DT	Deadtime, LS turn-off to HS turn-on & HS turn-on to LS turn-off	$V_{CC} = 12 / 24\text{ V}$	220	270	320	

STATIC ELECTRICAL CHARACTERISTICS

$V_{CC} = 12\text{ V}$ and $T_A = 25^\circ\text{C}$ unless otherwise specified.

Symbol	Parameter	Condition	Min.	Typ.	Max.	Unit
V_{CC}	Power supply voltage		4.0	---	28	V
V_{CCUV+}	V_{CC} supply undervoltage positive going threshold	$V_{CC} = 12 / 24\text{ V}$	3.5	3.7	3.95	V
V_{CCUV-}	V_{CC} supply undervoltage negative going threshold		3.1	3.3	3.6	
V_{IH}	Logic "1" input voltage		1.8	---	---	
V_{IL}	Logic "0" input voltage		---	---	0.7	
I_{CC0}	Quiescent current (standby mode)	$V_{CC} = 12 / 24\text{ V}$, EN = "0"	---	---	1	μA
I_{CC1}	Operating current (no load)	$V_{CC} = 12 / 24\text{ V}$, EN = "1"	---	1.5	2.3	mA
I_{IN}	Input current	$V_{CC} = 12 / 24\text{ V}$, $V_{IN} = 5\text{ V}$	40	56	65	μA
T_{SD}	Thermal shutdown temperature		150	160	170	$^\circ\text{C}$
T_{SD_HYS}	Thermal shutdown hysteresis			25		$^\circ\text{C}$
$R_{DS(ON)}$	Output ON resistance (high-side and low-side total)	$I_{OUT} = 0.8\text{ A}$	550	650	900	m Ω
I_{OLEAK}	Output leakage current	$V_O = 30\text{ V}$	---	---	10	μA
V_D	Diode forward voltage	$I_D = 0.8\text{ A}$	---	1.0	1.2	V

APPLICATION INFORMATION

STM Output Control Logic

ENA	Input		Output				State
	IN1	IN2	OUT1	OUT2	OUT3	OUT4	
L	-	-	OFF	OFF	OFF	OFF	Stand-by
H	L	L	H	L	H	L	Step 1
	H	L	L	H	H	L	Step2
	H	H	L	H	L	H	Step3
	L	H	H	L	L	H	Step4

Figure 3 Control Logic

Timing

About the switch time from the stand-by state to the state of operation, this IC has completely stopped operating when ENA pin is logic "0". After the time of reset of about 7 μ s of and internal setting, it shifts to a prescribed output status corresponding to the state of the input when ENA pin is logic "1".

During reset time, all output TR OFF is maintained.

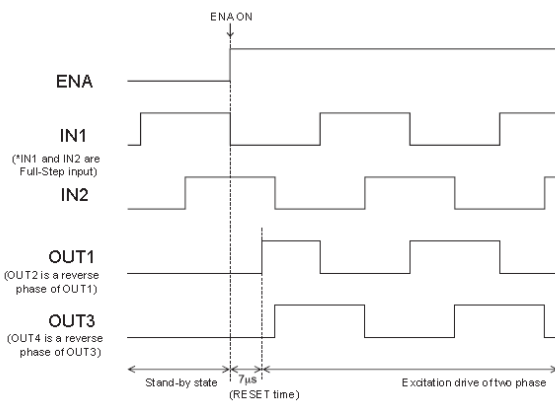

Figure 4 Control Timing

Current Waveforms

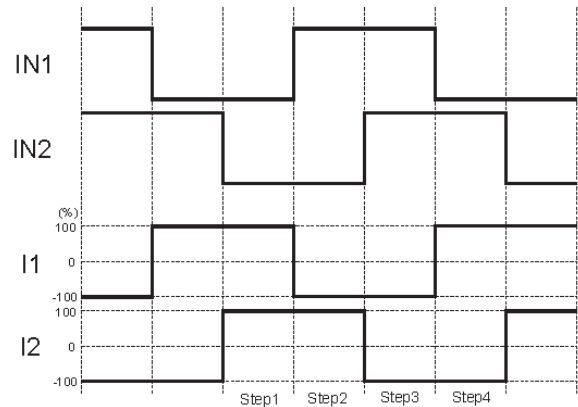

Figure 5 Full-step Mode

Thermal Shutdown

The thermal shutdown circuit is incorporated and the output is turned off when junction temperature exceeds 160°C. As the temperature falls by hysteresis, the output turned on again.

The thermal shutdown circuit doesn't guarantee the protection of the final product because it operates when the temperature exceed the junction temperature of $T_{jmax}=150^{\circ}\text{C}$.

$$T_{SD} = 160^{\circ}\text{C (TYP)}$$

$$T_{SD_HYS} = 25^{\circ}\text{C (TYP)}$$

CLASSIFICATION REFLOW PROFILES

Profile Feature	Pb-Free Assembly
Preheat & Soak	
Temperature min (T _{smin})	150°C
Temperature max (T _{smax})	200°C
Time (T _{smin} to T _{smax}) (t _s)	60-120 seconds
Average ramp-up rate (T _{smax} to T _p)	3°C/second max.
Liquidous temperature (T _L)	217°C
Time at liquidous (t _L)	60-150 seconds
Peak package body temperature (T _p)*	Max 260°C
Time (t _p)** within 5°C of the specified classification temperature (T _c)	Max 30 seconds
Average ramp-down rate (T _p to T _{smax})	6°C/second max.
Time 25°C to peak temperature	8 minutes max.

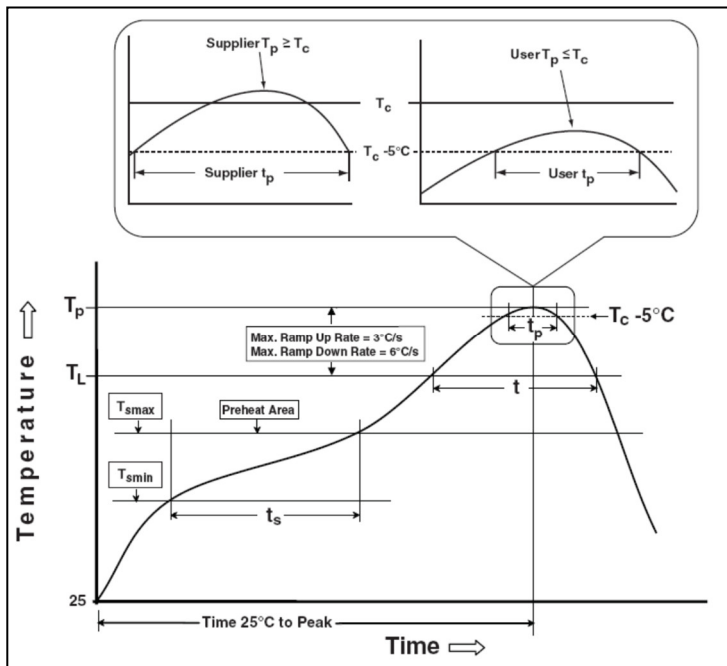
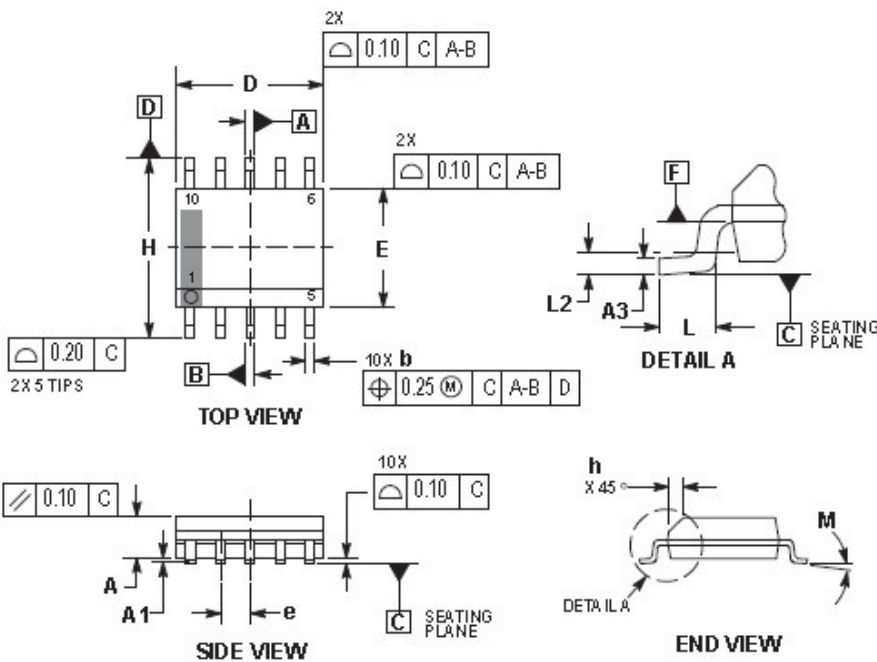

Figure 2 Classification Profile

PACKAGE CASE OUTLINES



NOTES:

1. DIMENSIONING AND TOLERANCING PER ASME Y14.5M, 1994.
2. CONTROLLING DIMENSION: MILLIMETERS.
3. DIMENSION b DOES NOT INCLUDE DAMBAR PROTRUSION. ALLOWABLE PROTRUSION SHALL BE 0.10mm TOTAL IN EXCESS OF 'b' AT MAXIMUM MATERIAL CONDITION.
4. DIMENSIONS D AND E DO NOT INCLUDE MOLD FLASH, PROTRUSIONS, OR GATE BURRS. MOLD FLASH, PROTRUSIONS, OR GATE BURRS SHALL NOT EXCEED 0.15mm PER SIDE. DIMENSIONS D AND E ARE DETERMINED AT DATUM F.
5. DIMENSIONS A AND B ARE TO BE DETERMINED AT DATUM F.
6. A1 IS DEFINED AS THE VERTICAL DISTANCE FROM THE SEATING PLANE TO THE LOWEST POINT ON THE PACKAGE BODY.

DIM	MILLIMETERS	
	MIN	MAX
A	1.25	1.75
A1	0.10	0.25
A3	0.17	0.25
b	0.31	0.51
D	4.80	5.00
E	3.80	4.00
e	1.00 BSC	
H	5.80	6.20
h	0.37 REF	
L	0.40	1.27
L2	0.25 BSC	
M	0°	8°

RECOMMENDED SOLDERING FOOTPRINT

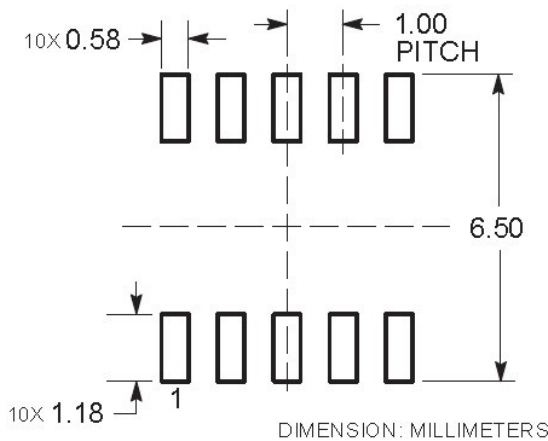

X-ON Electronics

Largest Supplier of Electrical and Electronic Components

Click to view similar products for [Motor/Motion/Ignition Controllers & Drivers](#) category:

Click to view products by [Keysemi](#) manufacturer:

Other Similar products are found below :

[LV8133JA-ZH](#) [LV8169MUTBG](#) [LV8774Q-AH](#) [LV8860PV-TLM-H](#) [MC33931EKR2](#) [MC34GD3000EP](#) [FSB50250UTD](#) [FSB50550TB2](#)
[FSBF15CH60BTH](#) [FSBS10CH60T](#) [MP6507GR-P](#) [MP6508GF](#) [MSVGW54-14-5](#) [NTE7043](#) [CAT3211MUTAG](#) [LA6245P-CL-TLM-E](#)
[LA6245P-TLM-E](#) [LA6565VR-TLM-E](#) [LB11650-E](#) [LB1694N-E](#) [LB1837M-TLM-E](#) [LB1845DAZ-XE](#) [LC898111AXB-MH](#) [LC898300XA-](#)
[MH](#) [SS30-TE-L-E](#) [STK531-345A-E](#) [STK581U3A0D-E](#) [STK58AUNP0D-E](#) [STK621-068C-E](#) [STK621-140C](#) [STK621-728S-E](#) [STK625-728-](#)
[E](#) [STK672-400B-E](#) [STK672-432AN-E](#) [STK672-432BN-E](#) [STK672-440AN-E](#) [STK672-442AN-E](#) [AMIS30621AUA](#) [FSB50550ASE](#) [26700](#)
[LV8161MUTAG](#) [LV8281VR-TLM-H](#) [LV8702V-TLM-H](#) [LV8734VZ-TLM-H](#) [LV8773Z-E](#) [LV8807QA-MH](#) [MC33932EK](#) [MCP8024T-](#)
[H/MP](#) [TND027MP-AZ](#) [BA5839FP-E2](#)