

DATE	DESCRIPTION	REV.
10.08.13	CHANGE AS PER ECN 13-091	A
1.03.17	CHANGE AS PER ECN 17-003 B1 WAS 2.822 [71.64]	B

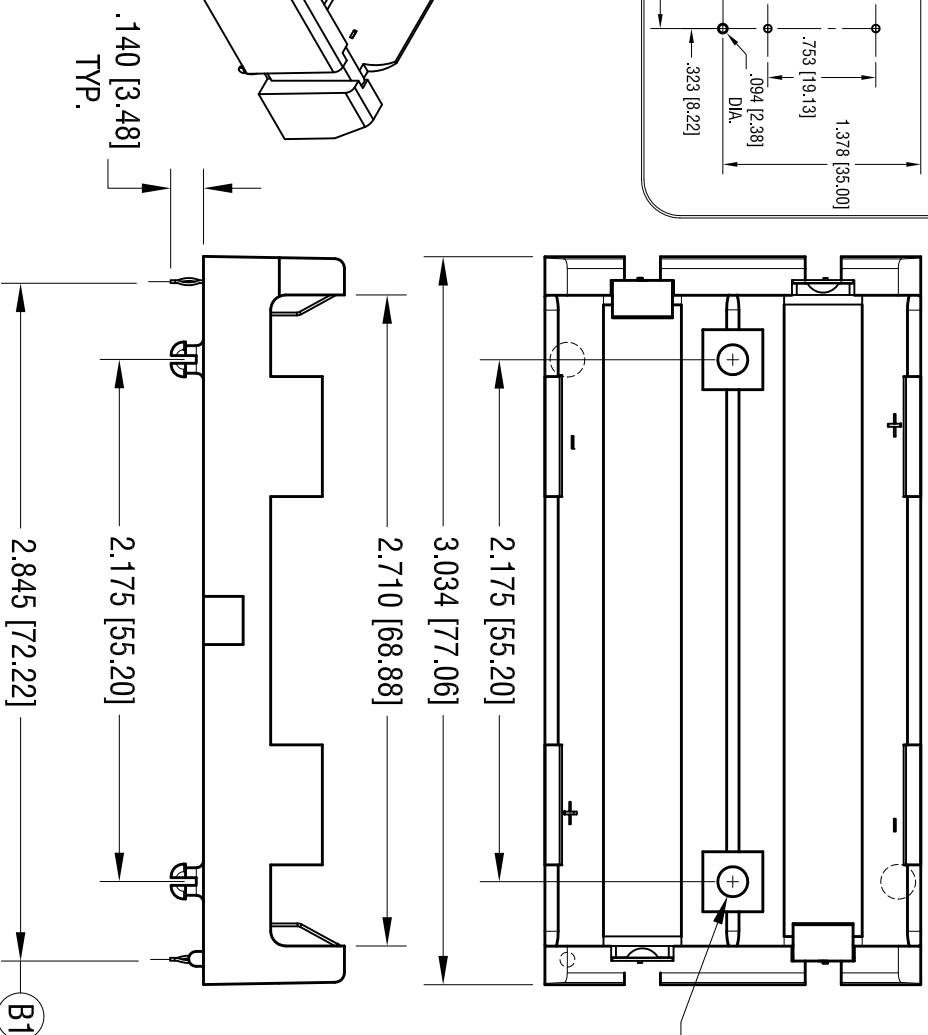

Ø.125 [Ø3.18] (2) PLS
DIA. MTG HOLE

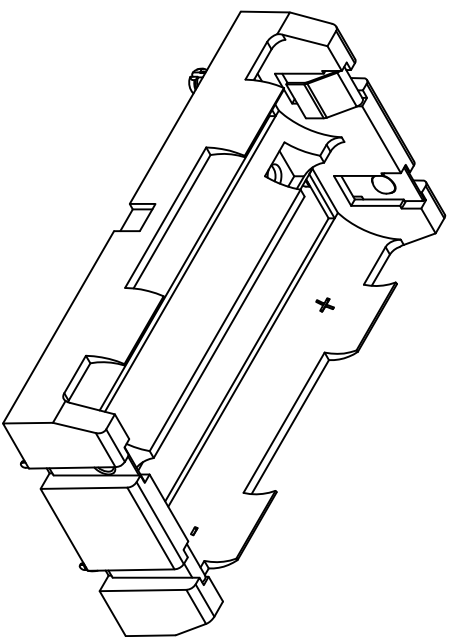
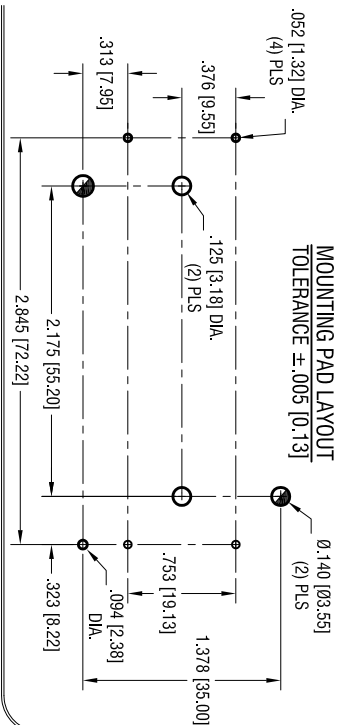
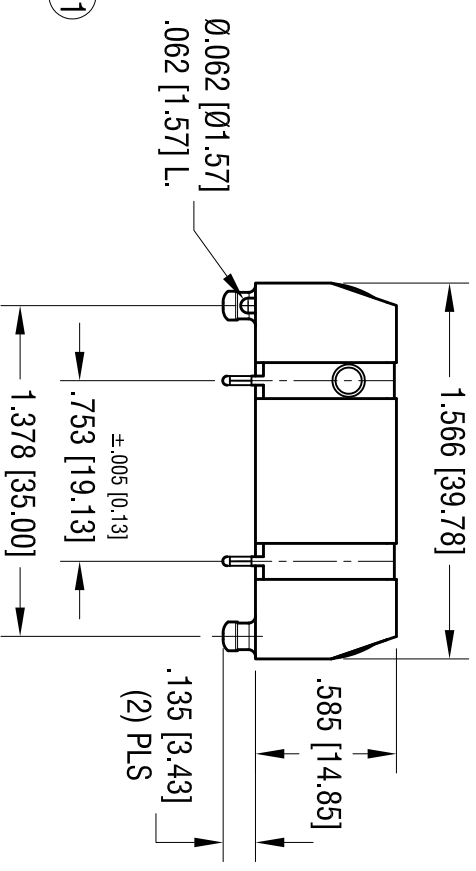

- NOTE:
1. BASE:
MATEL: HEAT RESISTANCE NYLON
STANVYL 46 OR EQUIVALENT
 2. CONTACT:
MATEL: .012 [0.30]THK STAINLESS STEEL
FINISH: TIN NICKEL PLATE
 3. HOLDER DESIGNED FOR LONGER BATTERIES
WITH BUILD IN CIRCUIT PROTECTION

THIS DOCUMENT IS THE PROPERTY OF
KEYSTONE ELECTRONICS CORP. AND
SHALL NOT BE REPRODUCED, DISTRIBUTED
OR USED AS A BASIS FOR MANUFACTURE
WITHOUT PRIOR WRITTEN PERMISSION
FROM KEYSTONE ELECTRONICS CORP.

KEYSTONE ELECTRONICS CORP.			
www.keystonectronics.com • ASTORIA, N.Y. 11105-2017 • Tel (718) 956-8900			
PART NAME			
DUAL THM POLARIZED HOLDER			
MATERIAL			
AS NOTED			
FINISH		AS NOTED	
TOLERANCES	INCH	[MM]	CODE
DECIMAL	± .010	[± 0.25]	C
ANGULAR	± 1°		
UNLESS OTHERWISE SPECIFIED			
DRN BY	NT	DATE	7.15.13
APPD		SCALE	1.25X
		1049P	

X-ON Electronics

Largest Supplier of Electrical and Electronic Components

Click to view similar products for [Cylindrical Battery Contacts, Clips, Holders & Springs](#) category:

Click to view products by [Keystone](#) manufacturer:

Other Similar products are found below :

[753-00001](#) [12BH36A-GR](#) [200](#) [183](#) [270](#) [QX3506](#) [5220](#) [5230](#) [1055](#) [1088](#) [5250](#) [166](#) [591](#) [1044](#) [KT0008](#) [1119](#) [254TR](#) [5207](#) [1121](#) [246](#)
[4027003022001-PK](#) [1012](#) [1020](#) [1024](#) [1024C](#) [1075](#) [1077](#) [1080](#) [1088](#) [1090](#) [1096](#) [1097](#) [1098](#) [1109](#) [1126](#) [1127](#) [1128](#) [1162](#) [1173](#) [147](#) [148](#)
[150](#) [151](#) [152](#) [153](#) [154](#) [155](#) [169](#) [171](#) [175](#)