

MOUNTING PAD LAYOUT

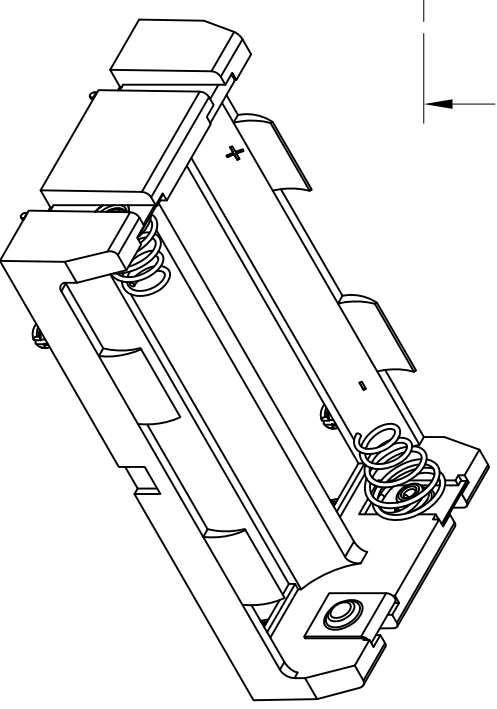
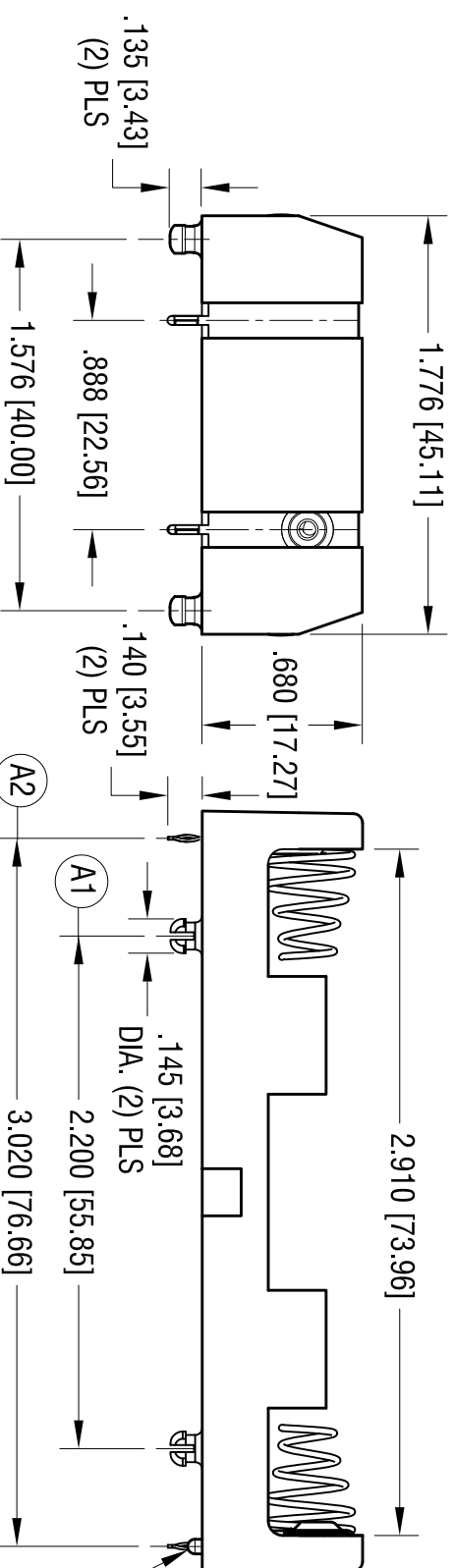
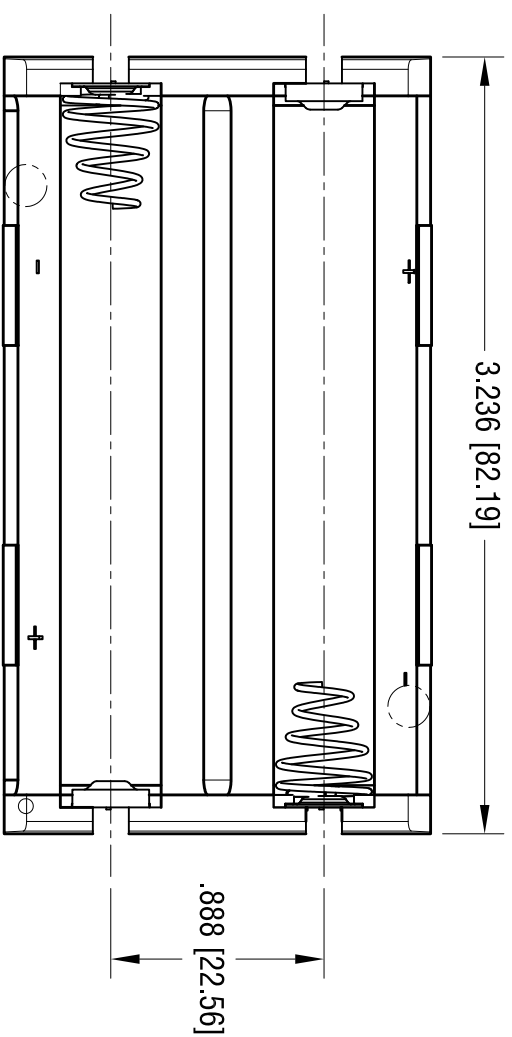
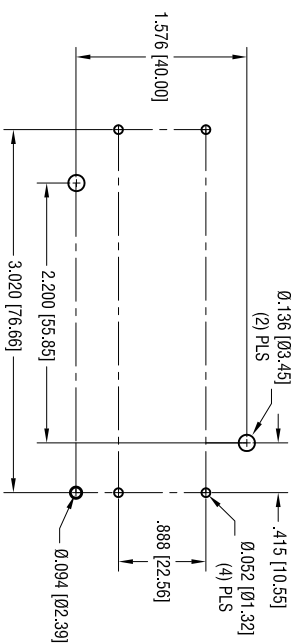

0.062 [01.57]  
x .062 [1.57] L.

DATE	DESCRIPTION	REV.
4.13.20	CHANGE AS PER ECN 20-038	A
	(A1) WAS 2.175 [55.20]	
	(A2) WAS 3.004 [76.30]	

**KEYSTONE ELECTRONICS CORP.**

www.keystone.com • NEW HYDE PARK, NY 11040 • Tel (516) 328-7500

PART NAME

THM BATTERY HOLDER FOR (2) 20700 & 21700

MATERIAL

AS NOTED

FINISH

AS NOTED

TOLERANCES	INCH	[MM]	CODE	DWG NO.
DECIMAL	± .010	[± .025]	C	1123
ANGULAR	± 1°			

DRN BY	DATE
NT	9.07.18

App'D	SCALE
	1.25X

NOTE:

1. BASE:  
MATERIAL: HEAT RESISTANT NYLON  
STANLYL 46 OR EQUIVALENT
2. CONTACT:  
MATERIAL: .012 [0.30] THK STAINLESS STEEL  
FINISH: NICKEL PLATE
3. SPRING:  
MATERIAL: .027 [0.68] DIA. MUSIC WIRE  
FINISH: NICKEL PLATE
4. SUPPLIED ON TRAY (25 PCS PER TRAY)

THIS DOCUMENT IS THE PROPERTY OF KEYSTONE ELECTRONICS CORP. AND SHALL NOT BE REPRODUCED, DISTRIBUTED OR USED AS A BASIS FOR MANUFACTURE WITHOUT PRIOR WRITTEN PERMISSION FROM KEYSTONE ELECTRONICS CORP.

## X-ON Electronics

Largest Supplier of Electrical and Electronic Components

*Click to view similar products for [Cylindrical Battery Contacts, Clips, Holders & Springs](#) category:*

*Click to view products by [Keystone](#) manufacturer:*

Other Similar products are found below :

[753-00001](#) [12BH36A-GR](#) [200](#) [183](#) [270](#) [QX3506](#) [5220](#) [5230](#) [1055](#) [1088](#) [5250](#) [166](#) [591](#) [1044](#) [KT0008](#) [1119](#) [254TR](#) [5207](#) [1121](#) [246](#)  
[4027003022001-PK](#) [12BHC186P2-GR](#) [9V \(6LR61\)](#) [PX1604](#) [1012](#) [1020](#) [1023](#) [1024](#) [1075](#) [1077](#) [1080](#) [1090](#) [1095](#) [1096](#) [1097](#) [1098](#) [1109](#)  
[1126](#) [1127](#) [1128](#) [1162](#) [1173](#) [147](#) [148](#) [149](#) [150](#) [151](#) [152](#) [153](#) [154](#) [155](#)