

THIS DOCUMENT IS THE PROPERTY OF KEYSTONE ELECTRONICS CORP. AND SHALL NOT BE REPRODUCED, DISTRIBUTED OR USED AS A BASIS FOR MANUFACTURE WITHOUT PRIOR WRITTEN PERMISSION FROM KEYSTONE ELECTRONICS CORP.

ACTUAL SIZE

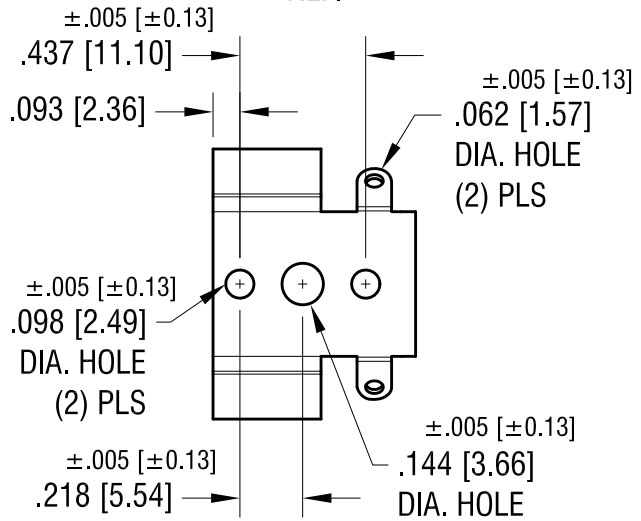
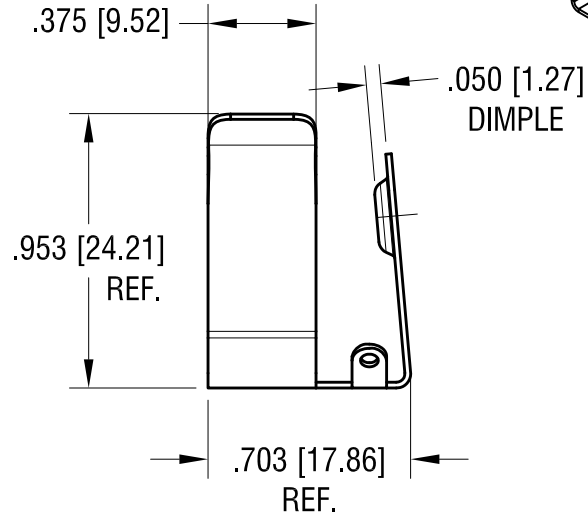
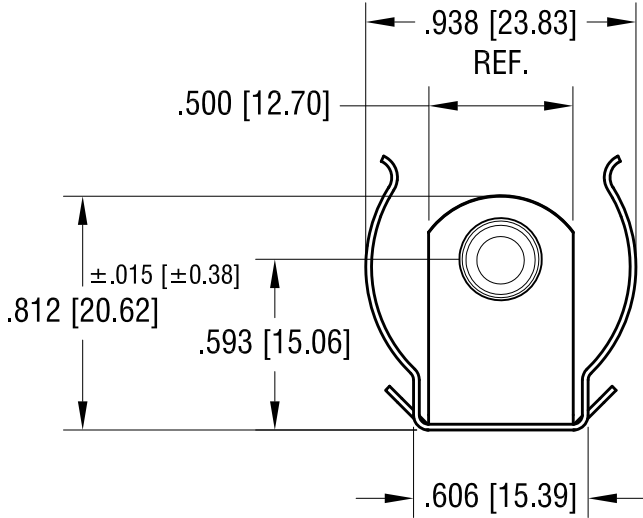
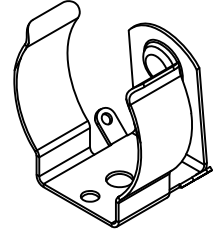

NOTE:

1. HEAT TREAT TO SPRING TEMPER.

10.06.16	CHANGE AS PER ECR 16-058	E
12.18.15	CHANGE AS PER ECN 15-146	D
6.14.04	CHANGE AS PER ECN 04-047	C
DATE	DESCRIPTION	REV.

KEYSTONE ELECTRONICS CORP.			
www.keyelco.com • ASTORIA, N.Y. 11105-2017 • Tel (718) 956-8900			
PART NAME		'C' CELL END CLIP	
MATERIAL		.020 [0.50] TH'K ANNEALED SPRING STEEL	
FINISH		DRN BY	DATE
NICKEL PLATE		BOONE	10.29.81
		APP'D	SCALE
			1.5X
TOLERANCES	INCH [MM]	CODE	DWG NO.
DECIMAL	± .010 [± 0.25]	C	86
ANGULAR	± 2°		
UNLESS OTHERWISE SPECIFIED			

X-ON Electronics

Largest Supplier of Electrical and Electronic Components

Click to view similar products for [Cylindrical Battery Contacts, Clips, Holders & Springs](#) category:

Click to view products by [Keystone](#) manufacturer:

Other Similar products are found below :

[753-00001](#) [12BH36A-GR](#) [200](#) [183](#) [270](#) [QX3506](#) [5220](#) [5230](#) [1055](#) [1088](#) [5250](#) [166](#) [591](#) [1044](#) [KT0008](#) [1119](#) [254TR](#) [5207](#) [1121](#) [246](#)
[4027003022001-PK](#) [1012](#) [1020](#) [1024](#) [1024C](#) [1075](#) [1077](#) [1080](#) [1088](#) [1090](#) [1096](#) [1097](#) [1098](#) [1109](#) [1126](#) [1127](#) [1128](#) [1162](#) [1173](#) [147](#) [148](#)
[150](#) [151](#) [152](#) [153](#) [154](#) [155](#) [169](#) [171](#) [175](#)