

1. Description

The KIA1117 series of positive adjustable and fixed regulators is designed to provide 1A for applications requiring high efficiency. All internal circuitry is designed to operate down to 800mA input to output differential and the dropout voltage is fully specified as a function of load current.

The KIA1117 offers current limiting and thermal protection. The on chip trimming adjusts the reference voltage accuracy to 2%.

2. Features

- Output current of 1A typical
- Three-terminal adjustable or fixed
- 1.5V, 1.8V, 2.5V, 2.85V, 3.0V, 3.3V, 5.0V outputs
- Thermal protection built in
- Fast transient response

3. Applications

- PC motherboard
- LCD monitor
- DVD-Video player
- NIC/switch
- Telecom equipment
- High efficiency linear regulator
- Printer and other peripheral equipment
- Battery charger

4. Pinning information

Table1: Pinning-SOT223, simplified outline

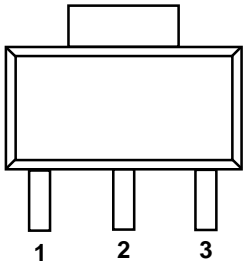
Pin	Description	Simplified outline
1	ADJ/GND	 <p>(SOT223 Front View)</p>
2	V_{OUT}	
3	V_{IN}	

5.Package information

2.5K/Reel 5K/Box 40K/CTN

6.Maximum ratings(Ta=25°C)

Table2: Maximum ratings

Parameter	Symbol	Rating	Unit
Input voltage	V_{IN}	12	V
Operating junction temperature	T_J	0~+125	°C
Storage temperature range	T_{STG}	-40~150	°C

7.Typical application

Table3: Typical application

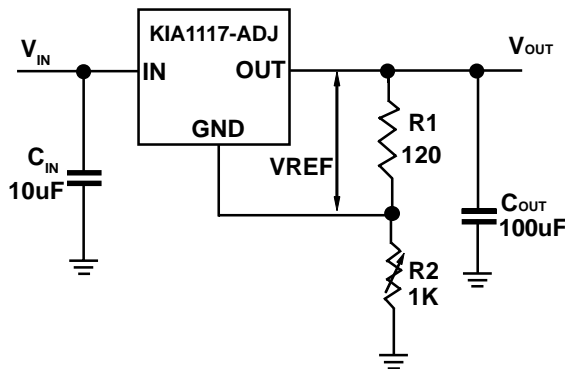

$$V_{OUT} = V_{REF} (1 + R2/R1) + I_{ADJ} R2$$

Application 1: 1.25V to 10V Adjustable Regulator

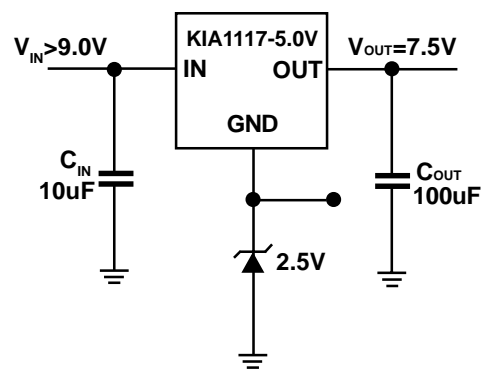

$$V_{OUT} = 7.5V$$

Application 2: Regulator with reference

8. Electrical characteristics

Table4: Electrical characteristics

($V_{IN}=10V, I_{OUT}=40mA, C_{IN}=0.33\mu F, C_{OUT}=0.1\mu F, T_J=25^\circ C$, Unless otherwise noted)

Parameter	Symbol	Condition	Min	Typ	Max	Unit
Reference voltage	V_{REF}	$I_{OUT}=10mA, V_{IN}-V_{OUT}=1.5V$	1.237	1.250	1.263	V
		$10mA \leq I_{OUT} \leq 1A$ $V_{OUT}+1.5V \leq V_{IN} \leq 12V$	1.225	1.250	1.275	V
Output voltage	1.5v	$10mA \leq I_{OUT} \leq 1A, 3.0V \leq V_{IN} \leq 12V$	1.470	1.500	1.530	V
	1.8v	$10mA \leq I_{OUT} \leq 1A, 3.3V \leq V_{IN} \leq 12V$	1.764	1.800	1.836	v
	2.5v	$10mA \leq I_{OUT} \leq 1A, 4.0V \leq V_{IN} \leq 12V$	2.450	2.500	2.550	v
	2.85v	$10mA \leq I_{OUT} \leq 1A, 4.35V \leq V_{IN} \leq 12V$	2.793	2.850	2.907	V
	3.0v	$10mA \leq I_{OUT} \leq 1A, 4.50V \leq V_{IN} \leq 12V$	2.940	3.000	3.060	V
	3.3v	$10mA \leq I_{OUT} \leq 1A, 4.80V \leq V_{IN} \leq 12V$	3.234	3.300	3.366	V
	5v	$10mA \leq I_{OUT} \leq 1A, 6.50V \leq V_{IN} \leq 12V$	4.900	5.000	5.100	V
Line regulation	ΔV_o	$I_{OUT}=10mA, V_{OUT}+1.5V \leq V_{IN} \leq 12V$		0.035	0.2	%
		$I_{OUT}=10mA, V_{OUT}+1.5V \leq V_{IN} \leq 12V$		1.0	6.0	mV
Load regulation	ΔV_o	$10mA \leq I_{OUT} \leq 1A, V_{IN}-V_{OUT}=3V$		0.2	0.4	%
		$10mA \leq I_{OUT} \leq 1A, V_{IN}=V_{OUT}+1.5V$		1.0	10.0	mV
Dropout voltage	ΔV	$I_{OUT}=10mA$		0.8	1.15	V
		$I_{OUT}=1A$		1.1	1.30	V
Minimum load current(Note1)	I_{MIN}	$V_{IN} \leq 12V$		5		mA
Quiescent current	I_Q	$V_{IN} \leq 12V$		5	10	mA
Current limit	I_{CL}	$V_{IN}-V_{OUT}=5V$	0.9	1.1	1.5	A
Adjust pin current		$I_{OUT}=10mA, V_{IN}-V_{OUT}=2V$		50	120	μA
Thermal regulation (Note2)		$T_A=25^\circ C, 30 \text{ ms pulse}$		0.008	0.04	%/W
Ripple rejection (Note2)	R_R	$f_o=120Hz, 1V_{RMS}, I_o=400mA,$ $V_{IN}-V_{OUT}=3V$	60	75		dB

Note1: For the adjustable device, the minimum load current is the minimum current required to maintain regulation.

Normally the current in the resistor divider used to set the output voltage is selected to meet the minimum load current requirement.

Note2: These parameters, although guaranteed, are not tested in production.

10.SOT223 package outline

Table5: SOT223 package outline

DIMENSIONS(mm are the original dimensions)

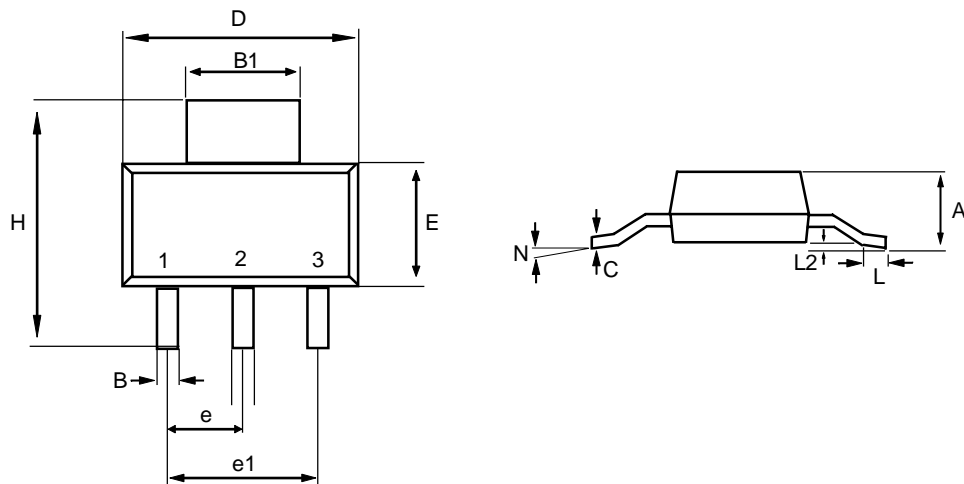

Dim	Min	Max	Dim	Min	Max
A	1.80REF		e	2.30REF	
B	0.60	0.80	e1	4.60REF	
B1	2.90	3.10	H	6.70	7.30
C	0.24	0.32	L	0.91	
D	6.30	6.70	L2	0.02	0.10
E	3.30	3.70	N	0°	10°

X-ON Electronics

Largest Supplier of Electrical and Electronic Components

Click to view similar products for [Linear Voltage Regulators](#) category:

Click to view products by [KIA](#) manufacturer:

Other Similar products are found below :

[LV56831P-E](#) [LV5684PVD-XH](#) [MCDTSA6-2R](#) [L7815ACV-DG](#) [PQ3DZ53U](#) [LV56801P-E](#) [TLE42794G](#) [L78L05CZ/1SX](#) [L78LR05DL-MA-E](#) [636416C](#) [714954EB](#) [BA033LBSG2-TR](#) [LV5680P-E](#) [L78M15CV-DG](#) [TLS202B1MBV33HTSA1](#) [L79M05T-E](#) [TLS202A1MBVHTSA1](#) [L78LR05D-MA-E](#) [NCV317MBTG](#) [NTE7227](#) [LV5680NPVC-XH](#) [LT1054CN8](#) [MP2018GZD-5-Z](#) [MP2018GZD-33-Z](#) [MIC5281-3.3YMM](#) [RT9078-28GQZ](#) [MC78L06BP-AP](#) [TA48LS05F\(TE85L,F\)](#) [TC47BR5003ECT](#) [TCR2LN12,LF\(S](#) [TCR2LN28,LF\(S](#) [TCR2LN30,LF\(S](#) [TCR3DF295,LM\(CT](#) [TCR3DF40,LM\(CT](#) [BA178M20CP-E2](#) [L78M05TL-TL-E](#) [L78M12ABDT](#) [LR645N3-G-P003](#) [LR645N3-G-P013](#) [ZXTR2005P5-13](#) [SCD7812BTG](#) [TCR3DF335,LM\(CT](#) [TLE42994E V33](#) [ZXTR2008K-13](#) [ZXTR2005K-13](#) [L88R05DL-E](#) [ADP3300ARTZ-2.7RL7](#) [LM120K-15/883](#) [IFX54441LDVXUMA1](#) [LM317D2T-TR](#)