

1. Features

The KXN5610A is the highest performance trench N-ch MOSFETS with extreme high cell density, which provide excellent RDSON and gate charge for most of the synchronous buck converter applications. The KNX5610A meet the RoHS and green product requirement.

2. Features

- $R_{DS(ON)}=98m\Omega(\text{typ.})@V_{GS}=10V$
- Advanced high cell density trench technology
- Super low gate charge
- Excellent Cdv/dt effect desline
- Green device available

3. Applications

- High frequency point-of-load synchronous buck converter
- Networking DC-DC power system
- Load switch

4.Symbol

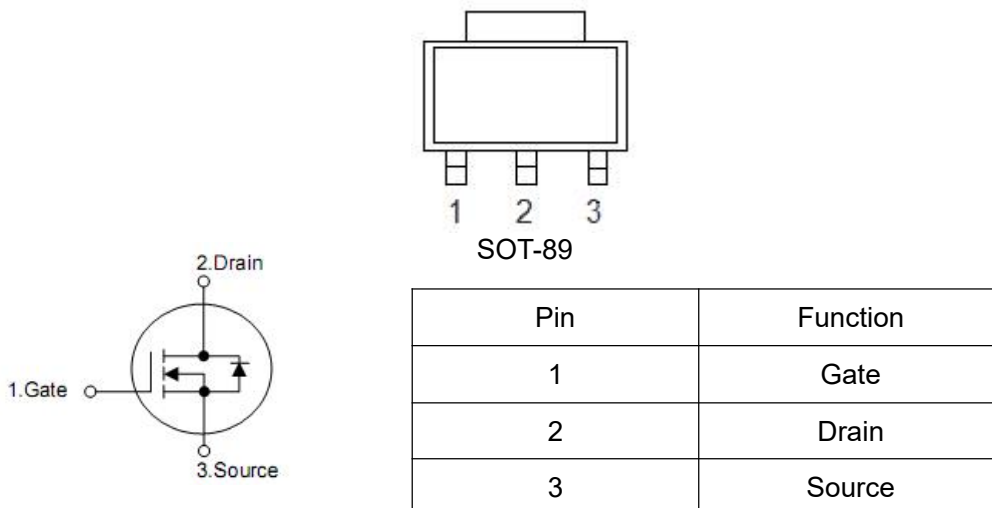

Part Number	Package	Brand
KNS5610A	SOT-89	KIA

4. Absolute maximum ratings

Parameter		Symbol	Rating	Units
Drain-source voltage		V_{DSS}	100	V
Gate-source voltage		V_{GS}	+20	V
Continuous drain current , $V_{GS}@10V$ ¹	$T_C=25^\circ C$	I_D	7*	A
	$T_C=100^\circ C$		5.2	
	$T_A=25^\circ C$		2	
	$T_A=100^\circ C$		1.4	
Pulsed drain current ²		I_{DM}	14	
Power dissipation ³	$T_C=25^\circ C$	P_D	22.7	W
	$T_A=25^\circ C$		2	
Avalanche current		I_{AS}	6	A
Operating junction and storage temperature range		T_J, T_{STG}	-55 to 150	$^\circ C$

* Drain current limited by maximum junction temperature.

5. Thermal characteristics

Parameter	Symbol	Typ	Max	Unit
Thermal resistance junction-case	$R_{\theta JC}$	-	2.6	$^\circ C/W$
Thermal resistance junction-ambient	$R_{\theta JA}$	-	48	

6. Electrical characteristics

(T_J=25°C, unless otherwise noted)

Parameter	Symbol	Test Conditions	Min	Typ	Max	Units
Drain-source breakdown voltage	BV _{DSS}	V _{GS} =0V, I _D =250μA	100	-	-	V
BV _{DSS} temperature coefficient	ΔBV _{DSS} /ΔT _J	Reference 25°C I _D =1mA	-	0.098	-	V/°C
Drain-source on-resistance ²	R _{DS(on)}	V _{GS} =10V, I _D =5A	-	98	115	mΩ
		V _{GS} =4.5V, I _D =3A	-	110	125	
Gate threshold voltage	V _{GS(TH)}	V _{DS} = V _{GS} , I _D =250uA	1.0	1.85	3.0	V
V _{GS(TH)} temperature coefficient	ΔV _{GS(TH)}		-	-4.57	-	mV/°C
Drain-source leakage current	I _{DSS}	V _{DS} =80V, V _{GS} =0V T _J =25°C	-	-	1	μA
		V _{DS} =80V, V _{GS} =0V T _J =55°C	-	-	5	
Gate-source forward leakage	I _{GSS}	V _{GS} =+20V, V _{DS} =0V	-	-	+100	nA
Forward transconductance	g _{fs}	V _{DS} =5V, I _D =10A	-	13	-	S
Gate resistance	R _g	V _{DS} =0V, V _{GS} =0V f=1MHz	-	1.8	-	Ω
Total gate charge(10V)	Q _g	V _{DS} =80V, I _D =10A V _{GS} =10V	-	26.2	-	nC
Gate-source charge	Q _{gs}		-	4.6	-	
Gate-drain charge	Q _{gd}		-	5.1	-	
Turn-on delay time	t _{d(on)}	V _{DD} =50V, I _D =10A, R _G =3.3Ω, V _{GS} =10V	-	4.2	-	ns
Rise time	t _r		-	8.2	-	
Turn-off delay time	t _{d(off)}		-	35.6	-	
Fall time	t _f		-	9.6	-	
Input capacitance	C _{iss}	V _{DS} =15V, V _{GS} =0V f=1MHz	-	1535	-	pF
Output capacitance	C _{oss}		-	60	-	
Reverse transfer capacitance	C _{rss}		-	37	-	
Continuous source current ^{1,6}	I _S	V _D =V _G =0V, Force current	-	-	7	A
Maximum pulsed current ^{2,6}	I _{SM}		-	-	49	
Diode forward voltage ²	V _{SD}	I _S =1A, V _{GS} =0V T _J =25°C	-	-	1.3	V
Reverse recovery time	t _{rr}	I _F =10A, di/dt=100A/μs T _J =25°C	-	37	-	ns
Reverse recovery charge	Q _{rr}		-	27.3	-	nC

Note:

1. The data tested by surface mounted on a 1 inch² board with 20Z copper.
2. The data tested by pulsed, pulse width ≤ 300μs, duty cycle ≤ 2%.
3. The power dissipation is limited by 150 °C junction temperature.
4. The min. value is 100% EAS tested guarantee.
5. The data is theoretically the same as I_D and I_{DM}, in real applications, should be limited by total power dissipation.

7. Typical operating characteristics

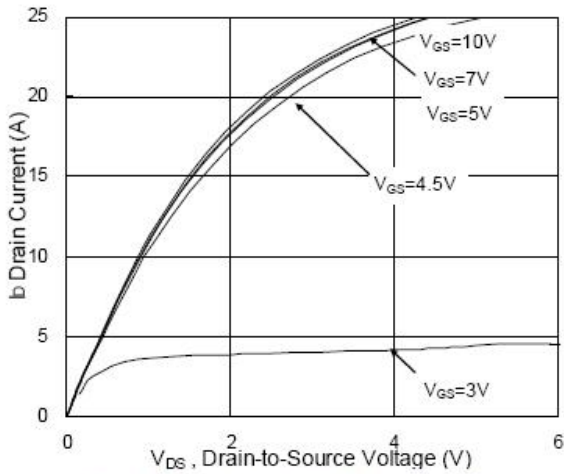

Fig.1 Typical output characteristics

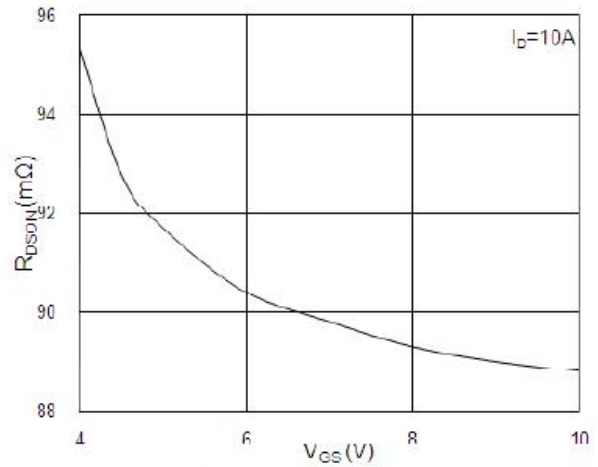

Fig.2 On-resistance vs. Gate-source

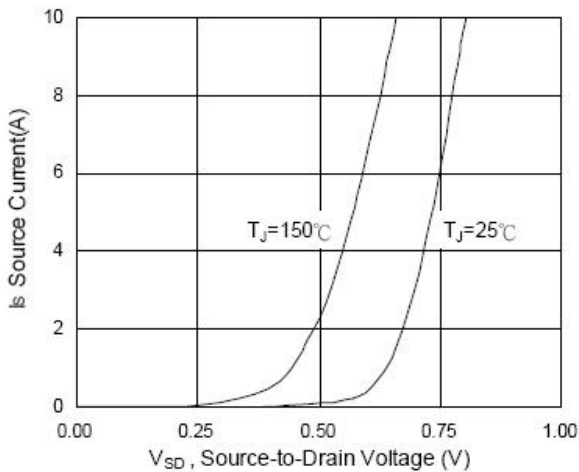

Fig.3 Forward characteristics of reverse

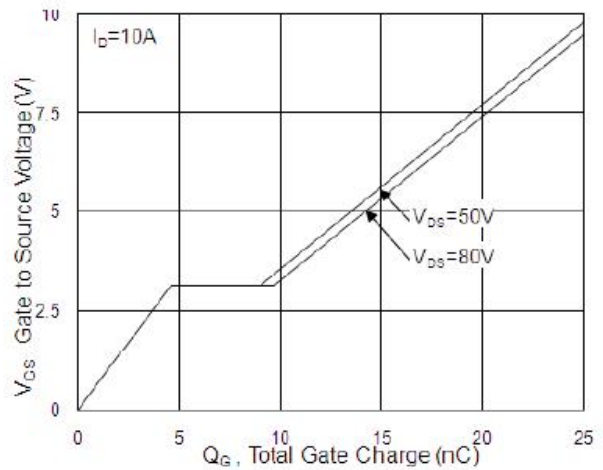

Fig.4 Gate-charge characteristics

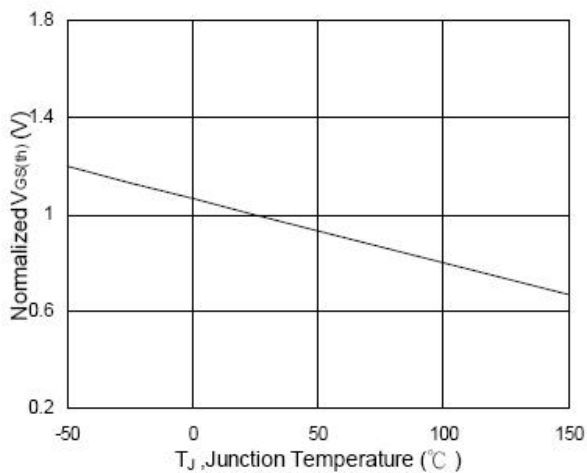

Fig.5 Normalized $V_{GS(th)}$ vs. T_J

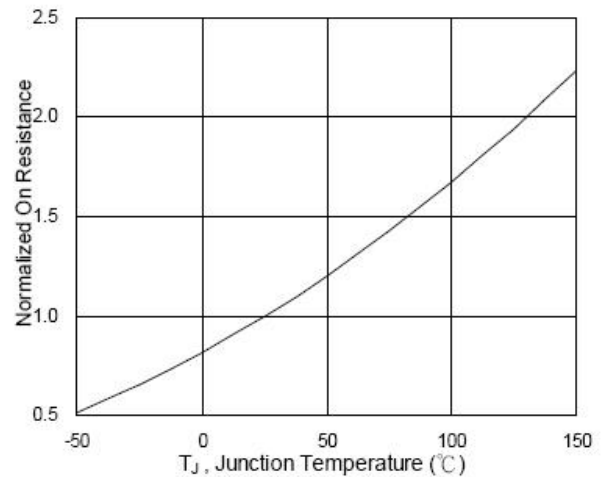

Fig.6 Normalized $R_{DS(on)}$ vs. T_J

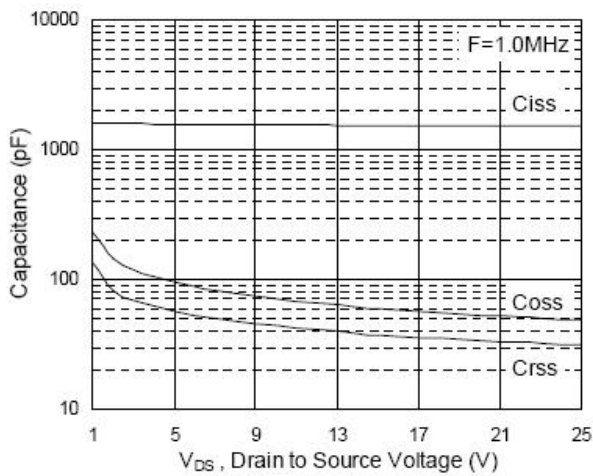

Fig.7 Capacitance

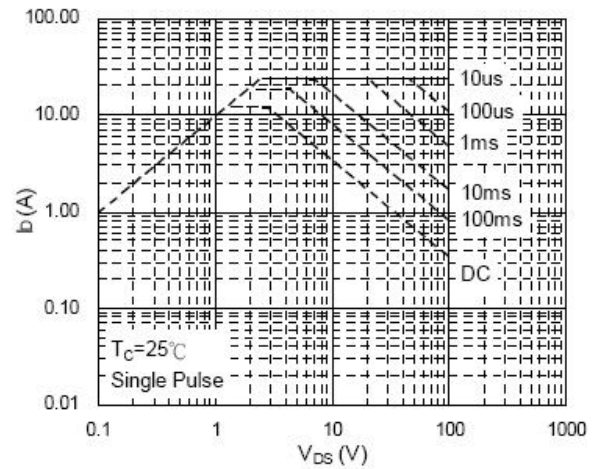

Fig.8 Safe operating area

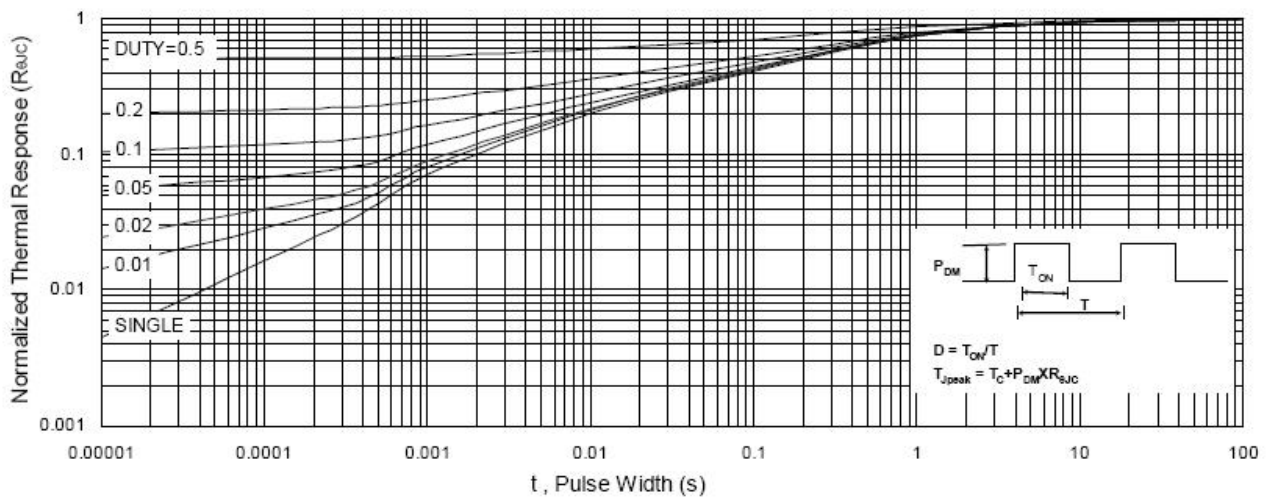

Fig.9 Normalized maximum transient thermal impedance

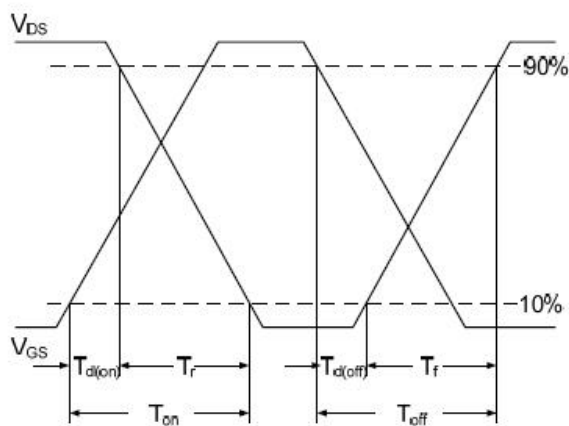

Fig.10 Switching time waveform

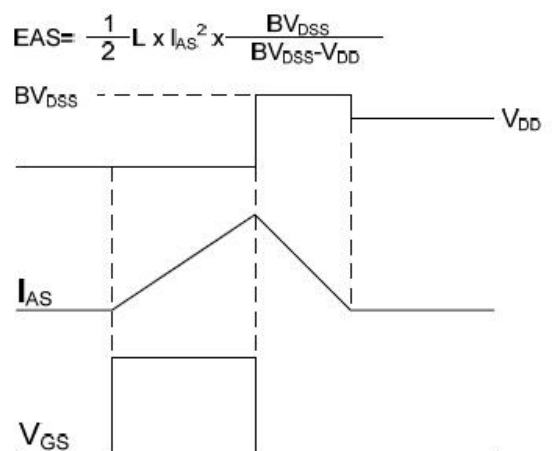

Fig.11 Gate charge waveform

X-ON Electronics

Largest Supplier of Electrical and Electronic Components

Click to view similar products for [MOSFET](#) category:

Click to view products by [KIA](#) manufacturer:

Other Similar products are found below :

[614233C](#) [648584F](#) [IRFD120](#) [IRFF430](#) [JANTX2N5237](#) [2N7000](#) [FCA20N60_F109](#) [FDZ595PZ](#) [AOD464](#) [2SK2267\(Q\)](#) [2SK2545\(Q,T\)](#)
[405094E](#) [423220D](#) [MIC4420CM-TR](#) [VN1206L](#) [614234A](#) [715780A](#) [SSM6J414TU,LF\(T](#) [751625C](#) [BSC884N03MS G](#) [BSF024N03LT3 G](#)
[PSMN4R2-30MLD](#) [TK31J60W5,S1VQ\(O](#) [2SK2614\(TE16L1,Q\)](#) [DMN1017UCP3-7](#) [EFC2J004NUZTDG](#) [FCAB21350L1](#) [P85W28HP2F-](#)
[7071](#) [DMN1053UCP4-7](#) [NTE2384](#) [NTE2969](#) [NTE6400A](#) [DMN2080UCB4-7](#) [DMN61D9UWQ-13](#) [US6M2GTR](#) [DMN31D5UDJ-7](#)
[SSM6P54TU,LF](#) [DMP22D4UFO-7B](#) [IPS60R3K4CEAKMA1](#) [DMN1006UCA6-7](#) [DMN16M9UCA6-7](#) [STF5N65M6](#) [STU5N65M6](#)
[C3M0021120D](#) [DMN13M9UCA6-7](#) [BSS340NWH6327XTSA1](#) [MCM3400A-TP](#) [DMTH10H4M6SPS-13](#) [IRF40SC240ARMA1](#)
[IPS60R1K0PFD7SAKMA1](#)