

## Load Switch with OVP and Reverse Polarity Protection

### Brief Description

The KTS1640 Evaluation (EVAL) Kit is used to demonstrate and evaluate the KTS1640 functionality, performance, and PCB layout. The kit includes a fully assembled and tested PCB with the KTS1640 IC installed, two pairs of high-current XT30-to-Banana power cables, and a printed copy of the Quick Start Guide (also contained within this document).

### Ordering Information

Part Number	Description	IC Package
KTS1640EDV-MMEV01	KTS1640 EVAL Kit	TDFN44-12

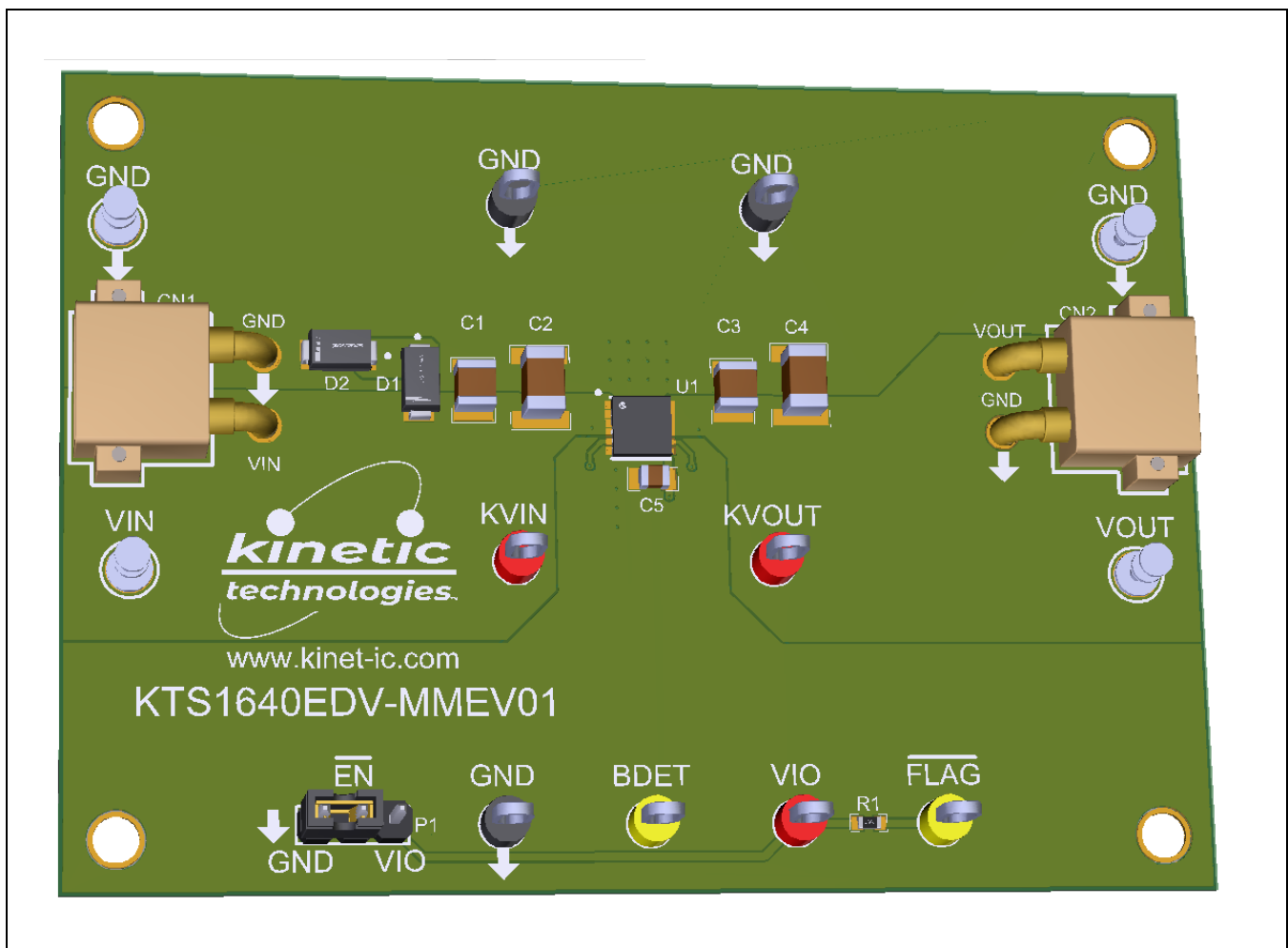

### 3D CAD Image



### EVAL Kit Physical Contents

Item #	Description	Quantity
1	KTS1640 EVAL fully assembled PCB	1
2	XT30-to-Banana power cables, red/black pair	2 pairs
3	Anti-static bag	1
4	Quick Start Guide, printed 1 page (A4 or US Letter)	1
5	EVAL Kit box	1

### QR Links for Documents

IC Landing Page	EVAL Kit Landing Page
 <a href="https://www.kinet-ic.com/KTS1640/">https://www.kinet-ic.com/KTS1640/</a>	 <a href="https://www.kinet-ic.com/kts1640edv-mmev01/">https://www.kinet-ic.com/kts1640edv-mmev01/</a>

### User-Supplied Equipment

#### Required Equipment

1. Bench Power Supply for VIN – 14V/30V and 0.5A/6A, as needed for the intended application. For testing over-voltage protection and withstand voltage, a 30V or 40V adjustable bench power supply is preferred.
2. Digital Multimeter – one or more, used to measure input/output voltages and currents.

#### Optional Equipment

1. Bench Power Supply for VIO – 1.5V to 5V, low current. Needed for shutdown mode ( $\overline{EN} = VIO = \text{High}$ ) and fault monitoring ( $\overline{FLAG}$  pull-up voltage).
2. Oscilloscope – for dynamic testing of voltages (and currents with a current probe, if available).
3. Load – either an eLoad, power resistors, or an actual system load.
4. Additional Digital Multimeters

### Recommended Operating Conditions

Symbol	Description	Value	Units
VIN	Input Withstand Voltage	-28 to 40	V
	Input Operating Voltage	6 to OVP (27V typ)	V
VIO	VIO Operating Voltage	1.5 to 5.5	V
I <sub>OUT</sub>	Output Load Current	0 to 6	A
I <sub>BDET</sub>	BDET Output Current	0 to 100	mA

### Jumper Descriptions

Designator	Name	Description	Default
P1	$\overline{EN}$	Active-Low Enable Input VIO (High): Shutdown Mode – switch disabled GND (Low): Enable Mode – normal switch operation	GND

### Quick Start Procedures

1. Set Jumpers to default:  $\overline{EN} = \text{GND}$
2. Connect one pair of XT30-to-Banana power cables to the XT30 connector at VIN and GND (left edge of EVAL Kit).
3. Before connecting the EVAL Kit to the VIN bench supply, turn on the supply and adjust the voltage as close to 0V as possible. Then turn off the supply. While off, connect the banana ends of the XT30-to-Banana power cables to the VIN bench supply.
4. Turn on the VIN bench supply and very slowly ramp its voltage to an appropriate voltage, such as 14V. While ramping VIN slowly, use the bench supply's output current indication (or a digital multimeter) to monitor the VIN current. If the current becomes high, reduce the VIN voltage quickly to prevent damage. Then inspect the setup for any wiring errors.
5. With valid VIN voltage, use a digital multimeter to check the output voltage between the KVOUT and GND terminals on the EVAL Kit. It should be nearly the same as the input voltage.
6. Use a digital multimeter to check the no-load supply current at VIN. Consult the KTS1640 datasheet for the expected current range at the VIN voltage condition in use. For conditions of VIN = 14V,  $\overline{EN} = \text{GND}$ , and no-load, it should be close to 145 $\mu\text{A}$ .

### Typical Test Setup Diagram

As an example, use the following test setup to measure items 5 and 6 in the Quick Start Procedures.

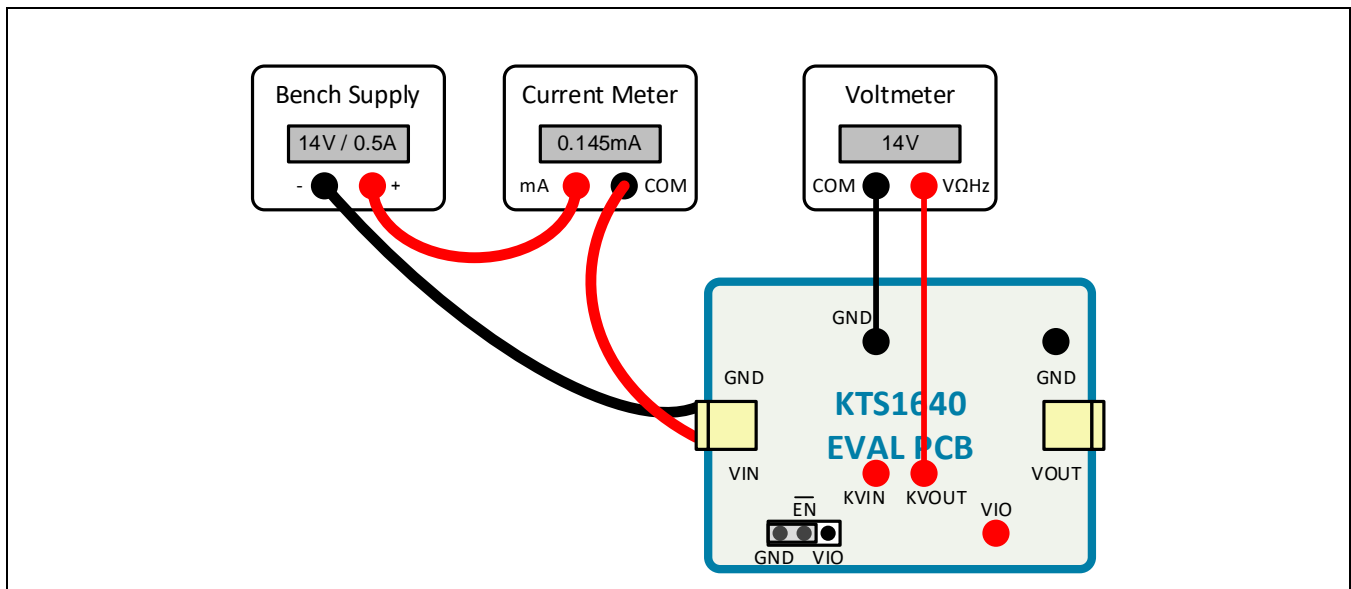

### Electrical Schematic

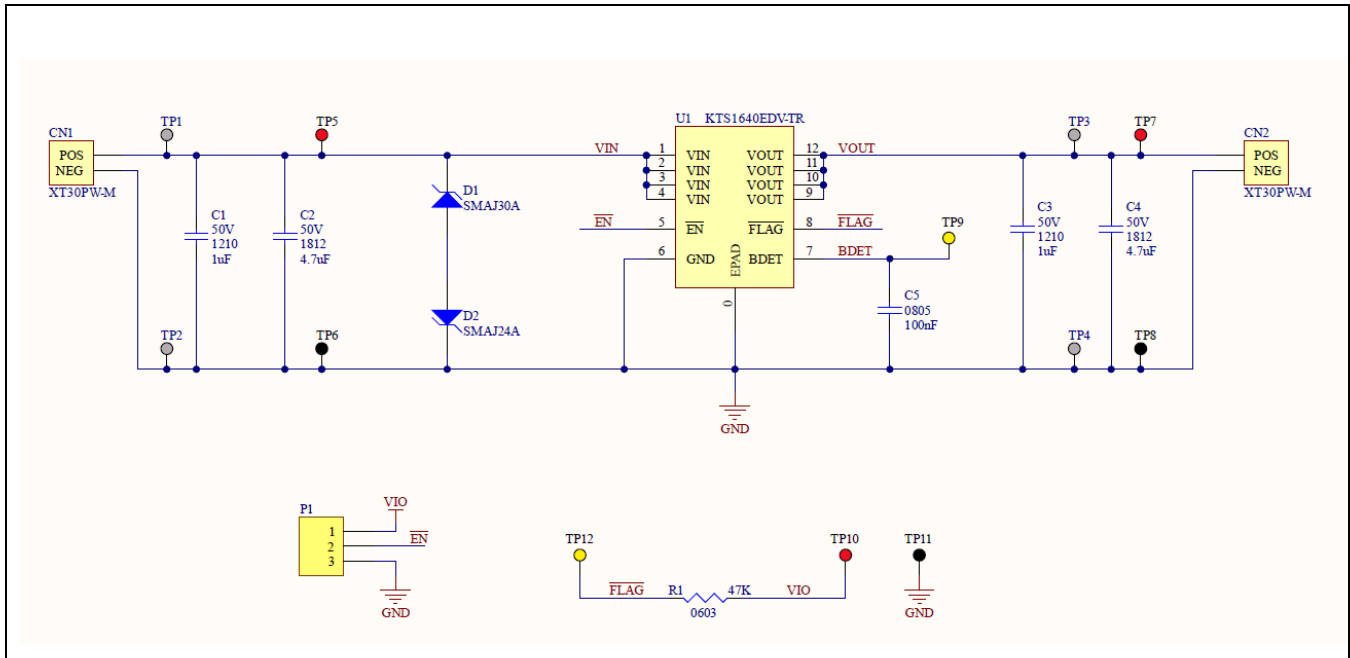

### Bill of Materials (BOM)

Quantity	Designator	Description	Value	Package	Manufacturer	Manufacturer Part Number	Digikey Part Number	Mouser Part Number
2	C1, C3	CAP 1UF 50V X7R 1210	1uF	1210	KEMET	C1210C105K5RAC7800	399-C1210C105K5RAC780 OCT-ND	N/A
2	C2, C4	CAP 4.7UF 50V X7R 1812	4.7uF	1812	TDK	CGA8M3X7R1H475KTOY ON	445-7906-1-ND	N/A
1	C5	CAP 0.1UF 50V X7R 0805	100nF	0805	Yageo	CC0805KRX7R9BB104	311-1140-1-ND	603-CC805KRX7R9BB104
2	CN1, CN2	30A Right Angle Through Hole Power Connectors			AMASS	XT30PW-M		
1	D1	TVS DIODE 30V 48.4V SMA		DO-214AC	Littelfuse Inc.	SMAJ30A	SMAJ30ALFCT-ND	576-SMAJ30A
1	D2	TVS DIODE 24VWM 38.9VC		DO-214AC	Littelfuse Inc.	SMAJ24A	SMAJ24ALFCT-ND	576-SMAJ24A
1	P1	3 Pin Header		Through Hole	Sullins Connector Solutions	PREC003SAAN-RC	S1012EC-03-ND	
1	R1	RES 47K 1% 1/10W 0603	47K	0603	Yageo	RC0603FR-0747KL	311-47.0KHRCT-ND	603-RC0603FR-0747KL
4	TP1, TP2, TP3, TP4	TERM TURRET SINGLE L=5.56MM TIN		1POS	Keystone	1502-2	36-1502-2-ND	534-1502-2
2	TP5, TP7	PC TEST POINT MULTIPURPOSE RED		Through Hole	Keystone	5010	36-5010-ND	534-5010
2	TP6, TP8	PC TEST POINT MULTIPURPOSE BLACK		Through Hole	Keystone	5011	36-5011-ND	534-5011
2	TP9, TP12	PC TEST POINT MULTIPURPOSE YELLOW		Through Hole	Keystone	5014	36-5014-ND	534-5014
1	TP10	PC TEST POINT MULTIPURPOSE RED		Through Hole	Keystone	5010	36-5010-ND	534-5010
1	TP11	PC TEST POINT MULTIPURPOSE BLACK		Through Hole	Keystone	5011	36-5011-ND	534-5011
1	U1	Load Switch with OVP and Reverse Polarity Protection		TDFN	Kinetic Technologies	KTS1640EDV-TR		389-KTS1640EDV-TR

### Printed Circuit Board (PCB)

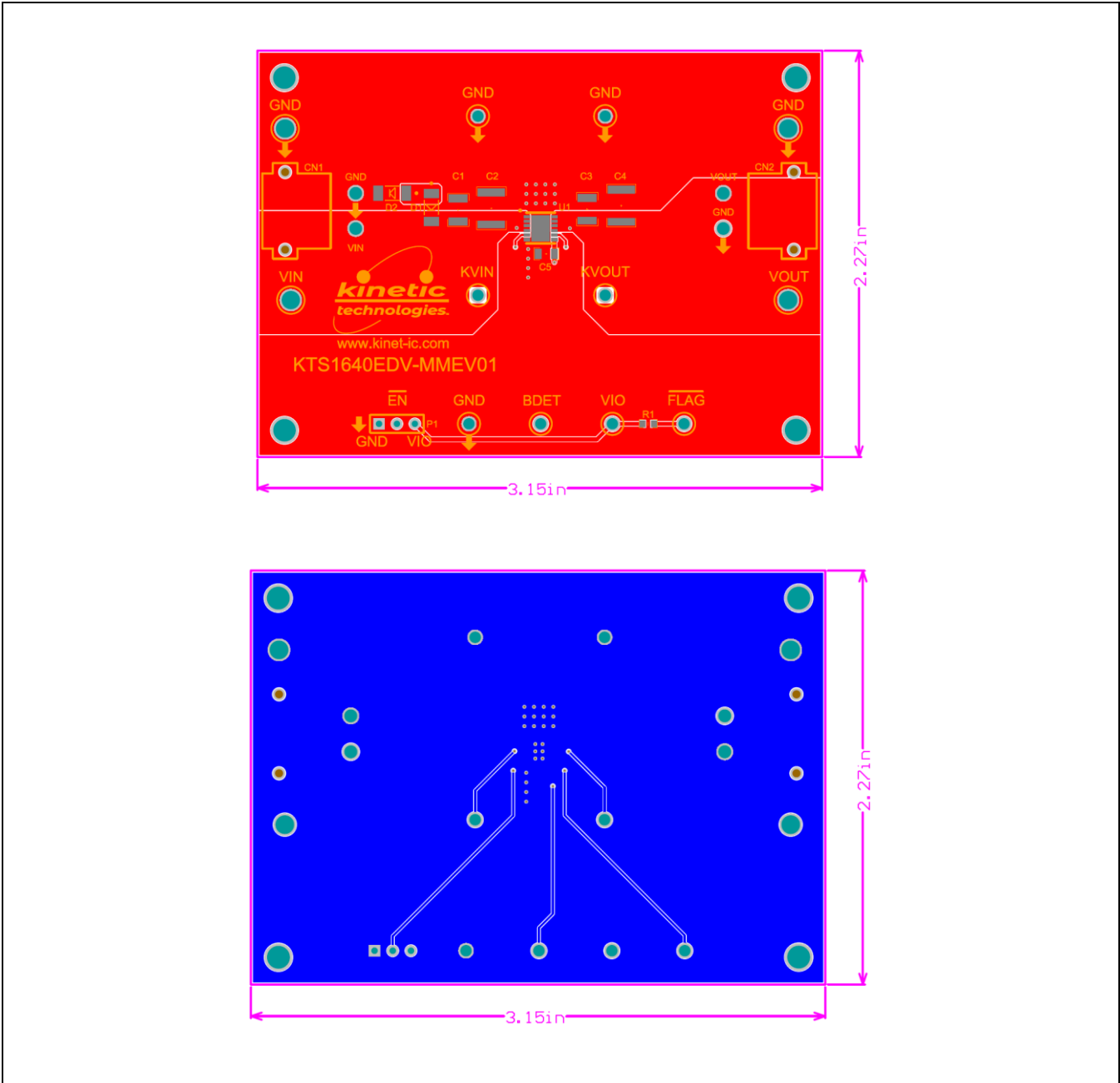

## Additional Test Procedures

1. Logic Pins Testing:
  - a. Before connecting the EVAL Kit to the VIO bench supply, turn on the supply and adjust the voltage as close to 0V as possible. Then turn off the supply. While off, connect the VIO bench supply to VIO and GND terminals on the EVAL Kit (with user-supplied banana-to-clip leads).
  - b. Turn on the VIO bench supply and very slowly ramp its voltage to an appropriate voltage, such as 1.8, 3.3, or 5V. While ramping VIO slowly, use the bench supply's output current indication (or a digital multimeter) to monitor the VIO current. If the current becomes high, reduce the VIO voltage quickly to prevent damage. Then inspect the setup for any wiring errors.
  - c. With valid VIO at 3V and VIN voltage at 14V, check the  $\overline{EN}$  and  $\overline{FLAG}$  functionality.
  - d. Check the shutdown supply current at VIN with  $\overline{EN} = VIO$ . The supply current should be a few  $\mu A$  only.  $\overline{FLAG}$  fault pin voltage should be close to VIO voltage.
  - e. With  $\overline{EN} = GND$ , check the  $\overline{FLAG}$  fault pulls low to GND when  $VIN < 5.3V$  (UVLO) and when  $VIN > 27.8V$  (OVLO).
2. Testing with Load:
  - a. Use the second XT30-to-Banana power cable pair to apply loads from VOUT to GND.
  - b. Under heavy-load conditions, use caution. The KTS1640 IC may become hot; avoid skin contact.
  - c. Use multimeters and an oscilloscope to make DC and transient measurements as desired.

## Troubleshooting

Symptom	Root Cause	Solution
$\overline{FLAG}$ does not go low during faults.	VIO supply is off or not connected.	Connect and enable a VIO pull-up supply. $\overline{FLAG}$ has an Absolute Maximum Rating of 7V.
$\overline{EN} = VIO$ does not disable the switch.	VIO supply is off or not connected.	Connect and enable a VIO pull-up supply. $\overline{EN}$ has an Absolute Maximum Rating of 7V

## Important Notices

### Legal notice

Copyright © Kinetic Technologies. Other names, brands and trademarks are the property of others.

Kinetic Technologies assumes no responsibility or liability for information contained in this document. Kinetic Technologies reserves the right to make corrections, modifications, enhancements, improvements, and other changes to its products and services at any time and to discontinue any product or services without notice. The information contained herein is believed to be accurate and reliable at the time of printing.

### Reference design policy

This document is provided as a design reference and Kinetic Technologies assumes no responsibility or liability for the information contained in this document. Kinetic Technologies reserves the right to make corrections, modifications, enhancements, improvements, and other changes to this reference design documentation without notice.

Reference designs are created using Kinetic Technologies' published specifications as well as the published specifications of other device manufacturers. This information may not be current at the time the reference design is built. Kinetic Technologies and/or its licensors do not warrant the accuracy or completeness of the specifications or any information contained therein.

Kinetic Technologies does not warrant that the designs are production worthy. Customer should completely validate and test the design implementation to confirm the system functionality for the end use application.

Kinetic Technologies provides its customers with limited product warranties, according to the standard Kinetic Technologies terms and conditions.

For the most current product information visit us at [www.kinet-ic.com](http://www.kinet-ic.com)

### Life support policy

LIFE SUPPORT: KINETIC TECHNOLOGIES' PRODUCTS ARE NOT DESIGNED, INTENDED, OR AUTHORIZED FOR USE AS COMPONENTS IN LIFE SUPPORT DEVICES OR SYSTEMS. NO WARRANTY, EXPRESS OR IMPLIED, IS MADE FOR THIS USE. AUTHORIZATION FOR SUCH USE SHALL NOT BE GIVEN BY KINETIC TECHNOLOGIES, AND THE PRODUCTS SHALL NOT BE USED IN SUCH DEVICES OR SYSTEMS, EXCEPT UPON THE WRITTEN APPROVAL OF THE PRESIDENT OF KINETIC TECHNOLOGIES FOLLOWING A DETERMINATION BY KINETIC TECHNOLOGIES THAT SUCH USE IS FEASIBLE. SUCH APPROVAL MAY BE WITHHELD FOR ANY OR NO REASON.

"Life support devices or systems" are devices or systems which (1) are intended for surgical implant into the human body, (2) support or sustain human life, or (3) monitor critical bodily functions including, but not limited to, cardiac, respirator, and neurological functions, and whose failure to perform can be reasonably expected to result in a significant bodily injury to the user. A "critical component" is any component of a life support device or system whose failure to perform can be reasonably expected to cause the failure of the life support device or system, or to affect its safety or effectiveness.

### SUBSTANCE COMPLIANCE

Kinetic Technologies IC products are compliant with RoHS, formally known as Directive 2002/95/EC of the European Parliament and of the Council of 27 January 2003 on the restriction of the use of certain hazardous substances in electrical and electronic equipment. However, this evaluation kit does not fall within the scope of the EU directives regarding electromagnetic compatibility, restricted substances (RoHS), recycling (WEEE), FCC, CE or UL, and may not meet the requirements of these or related directives. To the best of our knowledge the information is true and correct as of the date of the original publication of the information. Kinetic Technologies bears no responsibility to update such statement.

## X-ON Electronics

Largest Supplier of Electrical and Electronic Components

*Click to view similar products for* [Power Management IC Development Tools](#) *category:*

*Click to view products by* [Kinetic Technologies](#) *manufacturer:*

Other Similar products are found below :

[EVB-EP5348UI](#) [DA9063-EVAL](#) [BQ24155EVM](#) [BQ25010EVM](#) [REG710EVM-5](#) [TPS54980EVM-022](#) [TPS65010EVM-230](#) [BQ24120EVM-001](#) [BQ24212EVM-678](#) [BQ3050EVM-001](#) [ISL9520EVAL1Z](#) [UCC3809EVM](#) [LM3691TL-1.2EV/NOPB](#) [SOT23-3EV-VREG](#) [SOT89-3EV-VREG](#) [TPS2458EVM](#) [TPS54229EEVM-056](#) [TPS54329EEVM-056](#) [MAX8556EVKIT](#) [MAX20012EVKIT#](#) [MAX15005AEVKIT+](#) [S6SBP203A8FVA1001](#) [TPS652510EVM](#) [STEVAL-ISA047V1](#) [ISL8502AEVAL1Z](#) [ISL8009AEVAL1Z](#) [TPS76901EVM-127](#) [FRDM-HB2001-EVM](#) [BM6208FS-EVK-001](#) [LM5115EVAL](#) [LP5900TL-2.5EV](#) [DRI0043](#) [7E.12.8.230.0002](#) [KITPF8100FRDMEVM](#) [NCP10671B05GEVB](#) [MAX20073EVKIT#](#) [EVB-EN6337QA](#) [AP3125AEV1](#) [NIV6350MT2GEVB](#) [XMCA1](#) [RD33771-48VEVM](#) [EVKT-MPM3695-10-A](#) [DEMO200W12VDCLLC](#) [SAMPLEBOXILD8150TOBO1](#) [MAX18066EVKIT#](#) [AP61100Z6-EVM](#) [AP62300WU-EVM](#) [KIT8020-CRD-8FF1217P-1](#) [KITPF8121FRDMEVM](#) [EV2174C-G-00A](#)