

Overvoltage Protector with Bidirectional Blocking and Surge Protection

Features

- Wide Input voltage range: 3.0V to +28V
- Integrated MOSFET switch 20mΩ typical
- 5A Continuous Current
- VP Select pin
 - ▶ Over-Voltage threshold trip 13V/17V
 - ▶ VSNS clamp 16V/20V max
- Fast Over-Voltage response time 100ns
- Low Quiescent Current: 160μA (typ.)
- Integrated Protection
 - ▶ Thermal Shutdown
 - ▶ Under voltage protection (UVLO)
 - ▶ Soft-Start
 - ▶ OUT to IN Reverse Blocking
- \overline{EN} , \overline{VSNS} , \overline{WRX} and \overline{FLAG} pins
- Integrated Surge Protection up to +/-100V
- Pb-free WLCSP 20-Bump, 0.4mm pitch
- -40°C to +85°C Temperature Range

Brief Description

The KTS1676 over-voltage protection device features high current integrated N-Channel MOSFETs with an ultra-low IN to OUT on-resistance of 20mΩ (typical). Low-voltage systems on the output are protected from voltage supply faults up to +28V. An internal clamp on the input protects the device from surges up to ±100V.

An input voltage exceeding the over-voltage threshold causes the internal MOSFETs to turn off, preventing excessive voltage from damaging downstream devices.

The KTS1676 has a selectable internal fixed OVLO threshold preset to either 13V or 17V (typical) and also supports reverse bias blocking, preventing any voltage present at OUT pin feeding back into IN when the device is in the Off state. The KTS1676 also provides a selectable, always ON, clamped output voltage of 16V or 20V max.

The KTS1676 also features additional protection including enhanced ESD and thermal to protect against over-load conditions.

The device is available in a RoHS and Green compliant 20-bump, 0.4mm pitch, 2.22mm x 1.82mm WLCSP.

Applications

- Smartphones and Tablets
- Mobile Internet Devices
- Peripherals

Typical Application

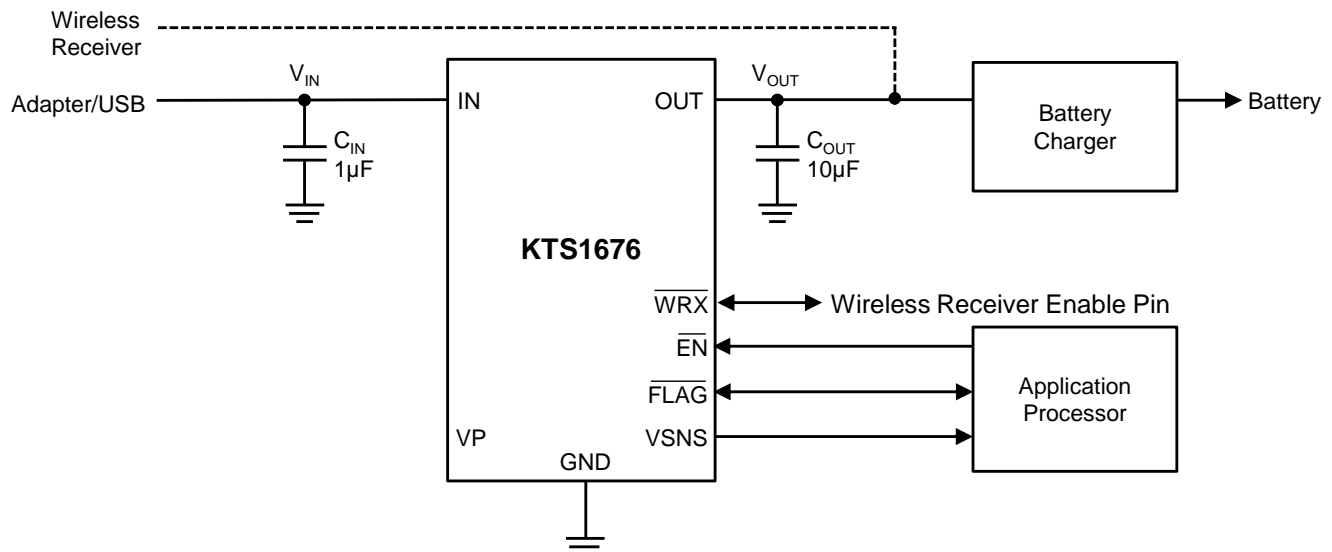

Ordering Information

Part Number	Marking ¹	Operating Temperature	Package
KTS1676EUT-TR	KOYYZZ	-40°C to +85°C	WLCSP-20

1. "YYZZ" is the date code and assembly code respectively.

Kinetic Technologies cannot assume responsibility for use of any circuitry other than circuitry entirely embodied in a Kinetic Technologies product. No intellectual property or circuit patent licenses are implied. Kinetic Technologies reserves the right to change the circuitry and specifications without notice at any time.

X-ON Electronics

Largest Supplier of Electrical and Electronic Components

Click to view similar products for [Power Switch ICs - Power Distribution](#) *category:*

Click to view products by [Kinetic Technologies](#) *manufacturer:*

Other Similar products are found below :

[TCK111G,LF\(S\)](#) [FPF1018](#) [DS1222](#) [TCK2065G,LF](#) [SZNCP3712ASNT3G](#) [MIC2033-05BYMT-T5](#) [MIC2033-12AYMT-T5](#) [MIC2033-05BYM6-T5](#) [SLG5NT1437VTR](#) [SZNCP3712ASNT1G](#) [NCV330MUTBG](#) [DML1008LDS-7](#) [KTS1670EDA-TR](#) [KTS1640QGDV-TR](#) [KTS1641QGDV-TR](#) [NCV459MNWTBG](#) [FPF2260ATMX](#) [U6513A](#) [U6119S](#) [NCP45780IMN24RTWG](#) [MAX14919ATP+](#) [MC33882PEP](#) [TPS2021HDRQ1](#) [TPS2104DBVR](#) [MIC2098-1YMT-TR](#) [MIC94062YMT TR](#) [MP6231DN-LF](#) [MIC2075-2YM](#) [MIC2095-2YMT-TR](#) [MIC94068YML-TR](#) [SIP32461DB-T2-GE1](#) [NCP335FCT2G](#) [FPF2701MX](#) [TCK105G,LF\(S\)](#) [AP2151DSG-13](#) [MIC94094YC6-TR](#) [MIC94064YC6-TR](#) [MIC2505-1YM](#) [MIC94042YFL-TR](#) [MIC94041YFL-TR](#) [MIC2005-1.2YM6-TR](#) [TPS2032QDRQ1](#) [SIP32510DT-T1-GE3](#) [NCP333FCT2G](#) [NCP331SNT1G](#) [TPS2092DR](#) [TPS2063DR](#) [TPS2042P](#) [MIC2008YML-TR](#) [MIC2040-1YMM](#)