

Low R_{ON} Load Switch with Overvoltage and Reverse Blocking Protection

Features

- Wide Input voltage range: 3V to 23V
- 30V Absolute Ratings at V_{IN} and V_{OUT}
- Maximum 5A continuous current
- Integrated FET with 30mΩ (Typ) R_{ON}
- Wide Overvoltage threshold range
 - ▶ Fixed internal: 23V
 - ▶ Adjustable: 4V to 23V
- Open-Drain power good indicator
- Integrated protection
 - ▶ Thermal Shutdown
 - ▶ Under-Voltage Lockout (UVLO)
 - ▶ Overvoltage Lockout (OVLO)
 - ▶ V_{OUT} to V_{IN} Reverse Current Blocking
 - ▶ Over-current limiting
- Surge and ESD Protection
 - ▶ IEC61000-4-5: ±90V for V_{IN}
 - ▶ IEC61000-4-2: ±8KV Contact, ±15KV Air for V_{IN}
 - ▶ HBM: ±2KV for all Pins
- Safety approvals
 - ▶ UL 2367, file no. E515099-2021-03-30
 - ▶ IEC 62368-1, file no. DK-111033-A1-UL
- Pb-free Package:
 - ▶ 15 Bump WLCSP 2.57mm x 1.57mm
 - ▶ RoHS and Green Compliant
- -40°C to +85°C Temperature Range

Brief Description

The KTS1677A is a slew-rate controlled, 30mΩ (Typ), low resistance MOSFET switch intended to be inserted between a power source and a load to isolate and protect against abnormal voltage and current conditions. Featuring slew-rate turn on control, to prevent excessive large inrush current, the KTS1677A also features several additional protection functions, such as input ±90V surge, input overvoltage, input under-voltage protection, reverse current blocking, over-current limiting and over-temperature protection.

Operating from a wide input voltage range of 3V to 30V can cover USB PD applications to offer essential protection and enhance system reliability. The KTS1677A in the OFF state can block voltages on the V_{IN}/V_{OUT} pin of up to 30V and prevent reverse currents. Two KTS1677A can be used in to support dual power inputs connecting to the same downstream device.

The device is packaged in advanced, RoHS and Green compliant, 2.57mm x 1.57mm, Wafer-Level Chip-Scale Package (WLCSP).

Applications

- Computers and Tablets
- Mobile Internet Devices
- Type-C Power Source Switch
- Storage, DSLR and Portable Devices

Typical Application



Pin Descriptions

Pin #	Name	Function
B2, C2, D2, E1, E2	V _{IN}	Power switch input
A1, B1, C1, D1	V _{OUT}	Power switch output
B3	OVLO	External OVLO Adjustment. Connect OVLO to GND when using the internal fixed threshold. Connect a resistor-divider to OVLO to set the adjustable OVLO threshold. The optional external resistor divider is unrelated to the internal threshold
A2	$\overline{\text{ACOK}}$	Power Good Indicate PIN with Open Drain output
C3, D3, E3	GND	Ground
A3	$\overline{\text{EN}}$	Enable input, active LOW.

WLCSP-15

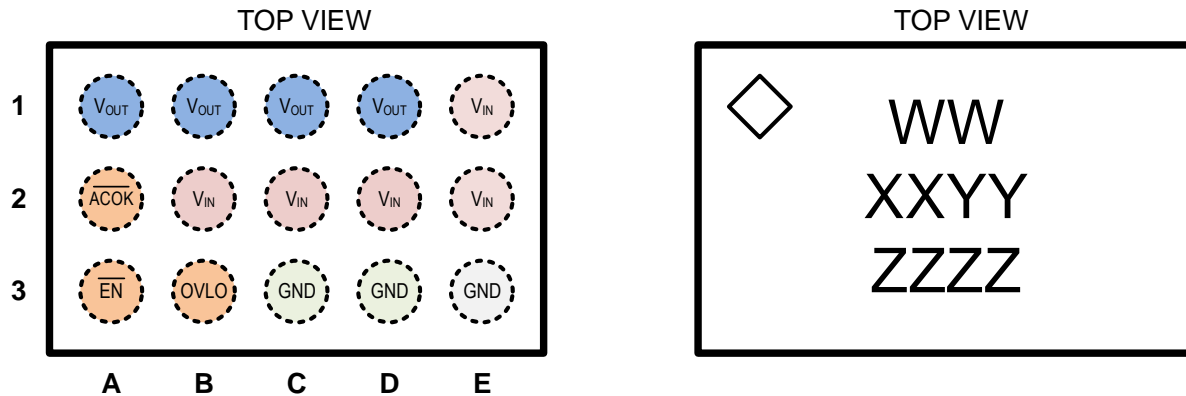

15-Bump 2.57mm x 1.57mm x 0.62mm
WLCSP Package

Top Mark

WW = Device ID Code
XX = Date Code, YY = Assembly Code
ZZZZ = Serial Number

Absolute Maximum Ratings¹

(T_A = 25°C unless otherwise noted, Voltages are referenced to GND)

Symbol	Description	Value	Units
V _{OUT}	Output voltage	-0.3 to 30	V
V _{IN}	Input Voltage	-0.3 to 30	
$\overline{\text{EN}}$	Enable Control	-0.3 to 30	
OVLO	OVLO Adjust Pins	-0.3 ~ V _{IN}	V
$\overline{\text{ACOK}}$	Power Good Flag	0.3 ~ 6	V
I _{sw}	Maximum Continuous Switch Current ²	5	A
T _J	Operating Junction Temperature	-40 to +150	°C
T _{STG}	Storage Junction Temperature	-65 to +150	°C

ESD Protections³

Symbol	Description	Value	Units
V _{ESD_HBM}	JESD22-A114 Human Body Model (all pins)	±2	kV
V _{ESD_CD}	IEC61000-4-2 Contact Discharge (IN pin)	±8	kV
V _{ESD_AGD}	IEC61000-4-2 Air Gap Discharge (IN pin)	±15	kV

Thermal Capabilities

Symbol	Description	Value	Units
θ _{JA}	Thermal Resistance – Junction to Ambient ⁴	64.3	°C/W
P _D	Maximum Power Dissipation at T _A ≤ 25°C	1.94	W
ΔP _D /ΔT	Derating Factor Above T _A = 25°C	-15.55	mW/°C

Recommended Operation Conditions⁵

Symbol	Description	Value	Units
V _{IN}	Supply Voltage	3 to 23	V
V _{OUT}	Output Voltage	3 to 23	V
$\overline{\text{ACOK}}$ /OVLO	Power Good Flag and OVLO Adjust Pins	0 to 5.5	V
$\overline{\text{EN}}$	Enable Control	0 to 20	V
C _{OUT}	Output Capacitance	10 to 1000	μF

Ordering Information

Part Number	Marking ⁶	Operating Temperature	Package
KTS1677AEVH-TR	NBXXYYZZZ	-40°C to +85°C	WLCSP-15

1. Stress exceeding the absolute maximum rating may damage the device. The device may not function or be operable above the recommended operating conditions and stressing the parts to these levels is not recommended. In addition, extended exposure to stresses above the recommended operating conditions may affect device reliability. The absolute maximum ratings are stress ratings only.
2. Maximum Ambient Temperature = 85°C
3. Guaranteed by characterization and design
4. Junction to Ambient thermal resistance is highly dependent on PCB layout. Values are based on thermal properties of the device when soldered to an EV board.
5. The recommended Operating Conditions table defines the conditions for actual device operation. Recommended operating conditions are specified to ensure optimal performance to the datasheet specifications. Kinetic does not recommend exceeding them or designing to Absolute Maximum Rating.
6. "WWXXYYZZZ" is the mark code, date code and assembly code.

Electrical Characteristics⁷

Unless otherwise noted, $V_{IN} = 3V$ to $23V$, $T_A = -40^{\circ}C$ to $+85^{\circ}C$, typical values are at $V_{IN} = 5V$ and $T_A = 25^{\circ}C$.

Symbol	Description	Conditions	Min	Typ	Max	Units
Basic Operation						
V_{IN}	Input Voltage		3		23	V
V_{OUT}	Output Voltage		3		23	V
V_{IN_CLAMP}	Input clamp voltage	$I_{IN} = 10mA$	30	32	34	V
I_Q	V_{IN} Quiescent Current	$I_{OUT} = 0mA, \overline{EN} = 0V, V_{IN} = 5V$		130	150	μA
		$I_{OUT} = 0mA, \overline{EN} = 0V, V_{IN} = 20V$		180	200	μA
I_{SD}	V_{IN} Shutdown Current	$I_{OUT} = 0mA, \overline{EN} = 5V, V_{IN} = 5V$		2	8	μA
		$I_{OUT} = 0mA, \overline{EN} = 5V, V_{IN} = 20V$		3	16	μA
Under-Voltage Protection						
V_{UVLO}	Under-Voltage Lockout	V_{IN} Increasing	2.3	2.7	3.0	V
V_{UVLO_HYS}	UVLO Hysteresis			0.2		V
Leakage						
I_{SW_OFF}	V_{IN} OFF Leakage Current	$\overline{EN} = 5V, V_{IN} = 5V, V_{OUT} = 0V$		2	8	μA
		$\overline{EN} = 5V, V_{IN} = 20V, V_{OUT} = 0V$		3	16	μA
	V_{OUT} OFF Leakage Current	$\overline{EN} = 5V, V_{IN} = 0V, V_{OUT} = 5V$		1	8	μA
		$\overline{EN} = 5V, V_{IN} = 0V, V_{OUT} = 20V$		3	16	μA
I_{SW_ON}	RCP Leakage	$\overline{EN} = 0V, V_{IN} = 0V, V_{OUT} = 5V$		115		μA
Switch						
R_{ON}	ON Resistance	$V_{IN} = 5.0V, T_A = 25^{\circ}C$		30	40	m Ω
		$V_{IN} = 20V, T_A = 25^{\circ}C$		30	40	
Enable						
V_{IH}	\overline{EN} Input Logic HIGH Voltage		1.4			V
V_{IL}	\overline{EN} Input Logic LOW Voltage				0.4	V
R_{pd}	\overline{EN} Pull-Down Resistance		1			M Ω
ACOK						
V_{OL_ACOK}	\overline{ACOK} Output Logic LOW Voltage	$I_{SINK} = 1mA$			0.2	V
I_{ACOK_LK}	\overline{ACOK} Output High Leakage Current	$V_{IO} = 5V, \text{Switch On}$	-1		1	μA
Overvoltage Protection						
V_{OV_TRIP}	Output OVP Lockout	Rising, $OVLO = 0V$	21.7	23	24.3	V
V_{OV_HYS}	Output OVP Hysteresis	$OVLO = 0V$		0.3		V
V_{TH_OVLO}	external OVLO set threshold voltage	$\overline{EN} = 0V$	1.14	1.22	1.30	V
V_{OV_SEL}	External OVLO select threshold	OVLO from external become effective once it exceeds this value	0.2	0.25	0.3	V
T_{OVP}	OVP Response Time	From $V_{IN} > V_{OVLO}$ to V_{OUT} stop rising; $R_{load} = 100\Omega, C_{load} = 0\mu F, V_{IN} = 20V, OVLO = 0V$		0.1		μs

7. KTS1677A is guaranteed to meet performance specifications over the $-40^{\circ}C$ to $+85^{\circ}C$ operating temperature range by design, characterization and correlation with statistical process controls.

Electrical Characteristics⁷

Unless otherwise noted, $V_{IN} = 3V$ to $23V$, $T_A = -40^{\circ}C$ to $+85^{\circ}C$, typical values are at $V_{IN} = 5V$ and $T_A = 25^{\circ}C$.

Symbol	Description	Conditions	Min	Typ	Max	Units
Over-current Limiting Protection⁸						
I_{LIM_TR}	Current limiting trip point		8.3	12.2		A
T_{REP}	Current limit response time. See Figure 6.	$I_{AMP} = 10A$	1			ms
		$I_{AMP} = 12.5A$	300			μs
		$I_{AMP} = 15A$	100			μs
I_{LIM}	I_{OUT} limit hold point		5.3	7.5		A
Reverse Current Protection (RCP)						
V_{RC_TRIG}	RCP threshold voltage	$V_{RC_TRIG} = V_{OUT} - V_{IN}$		80		mV
V_{RC_FTRIG}	RCP fast threshold voltage	$V_{RC_FTRIG} = V_{OUT} - V_{IN}$		120		mV
V_{RC_REC}	RCP recovery threshold voltage	$V_{RC_REC} = V_{IN} - V_{OUT}$		10		mV
T_{RC_REC}	RCP recovery response time	From $V_{in} > V_{OUT} + V_{RC_REC}$ to switch on		26		ms
T_{RC_DEGL}	RCP de-glitch time	From $V_{OUT} > V_{IN} + V_{RC_TRIG}$ to switch off		4.2		ms
T_{RC_OFF}	RCP turn-off time	From $V_{OUT} > V_{IN} + 120mV$ to switch off		10		μs
Dynamic Characteristics						
T_{DEB}	De-bounce Time ⁹	From \overline{EN} or $3V < V_{IN} < V_{IN_OVLO}$ to $V_{OUT} = 10\% * V_{IN}$. $V_{IN} = 5V, R_L = 100\Omega, C_L = 100\mu F$		15		ms
T_R	V_{OUT} Rise Time	V_{OUT} from 10% to 90% V_{IN} , $V_{IN} = 5V, R_L = 100\Omega, C_L = 100\mu F$		2.9		ms
		V_{OUT} from 10% to 90% V_{IN} , $V_{IN} = 20V, R_L = 100\Omega, C_L = 100\mu F$		10.6		ms
T_{OFF}	Turn-Off Delay	\overline{EN} to $V_{OUT} = 10\% * V_{IN}$ $V_{IN} = 5V, R_L = 100\Omega, C_L = 100\mu F$		23		ms
Thermal Shutdown						
T_{SD}	Thermal Shutdown			150		$^{\circ}C$
T_{HYST}	Thermal Hysteresis			20		$^{\circ}C$

8. Guaranteed by characterization and design

9. Timing as defined in Figure 1.

Typical Characteristics

$V_{IN} = 20V$, $C_{IN} = 0.1\mu F$, $C_{OUT} = 1\mu F$, OVLO pin = GND, $T_A = 25^\circ C$ unless otherwise specified.

Supply Current vs VIN vs Temperature

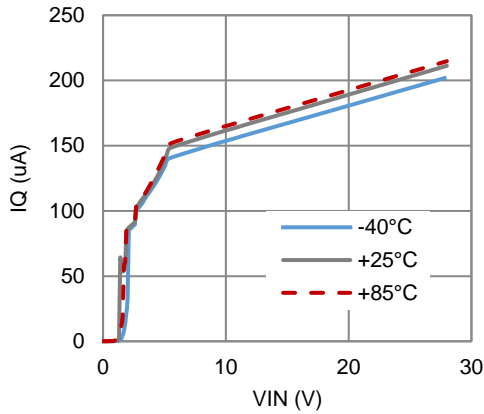

Shutdown Current vs VIN

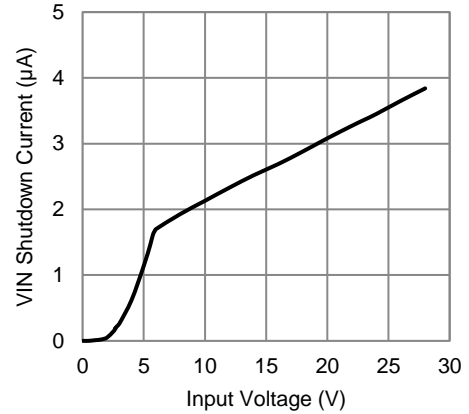

Normalized R_{DS(on)} vs. Output Current

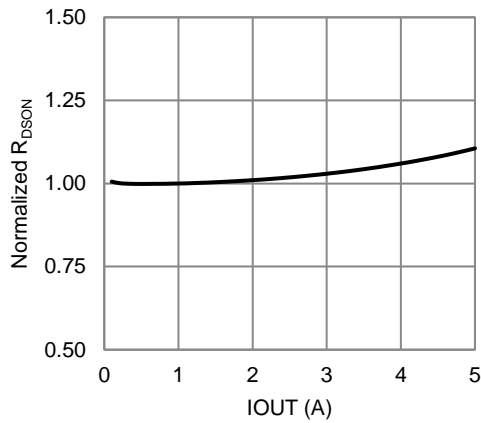

R_{DS(on)} vs. Temperature (I_{OUT} = 1A)

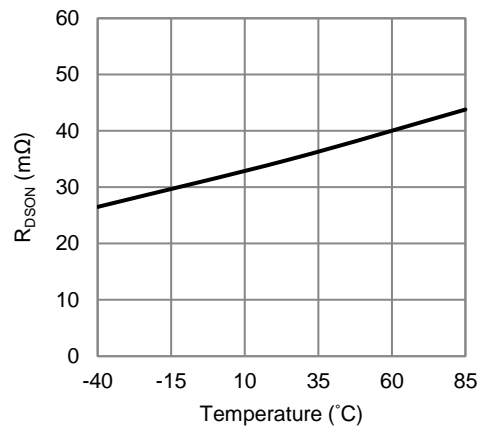

OFF-state Leakage Current on OUT pin

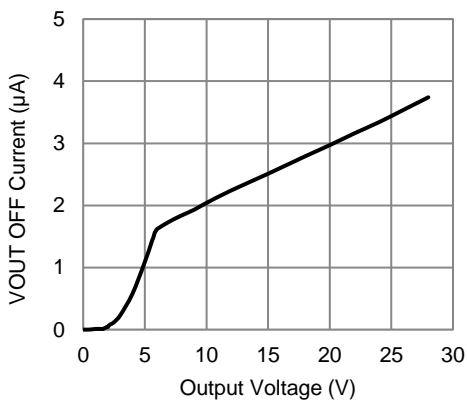

Normalized OVLO Set Threshold vs Temperature

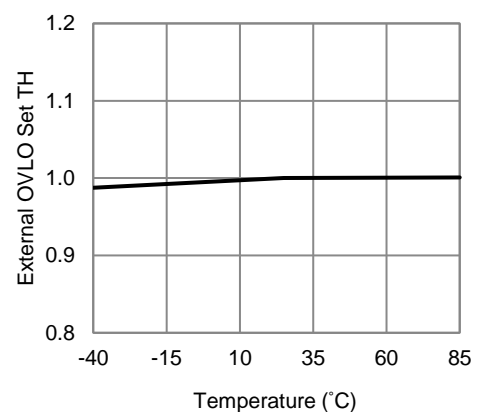

Typical Characteristics

$V_{IN} = 20V$, $C_{IN} = 0.1\mu F$, $C_{OUT} = 1\mu F$, OVLO pin = GND, $T_A = 25^\circ C$ unless otherwise specified.

Power-up ($C_{OUT} = 1\mu F$, 100Ω Load)

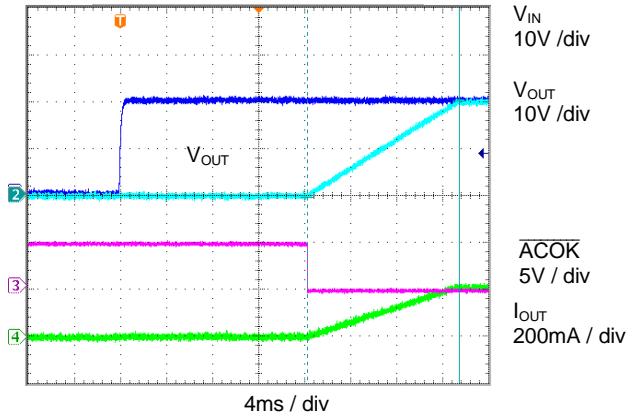

OVP Response Time ($V_{IN} = 20V$ to $90V$ Surge)

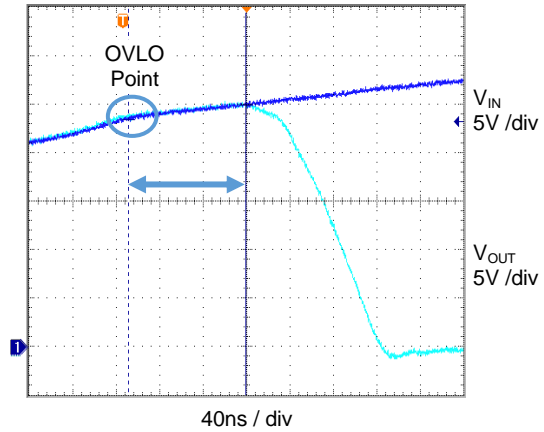

Short-Circuit Fault Protection (OUT short to GND)

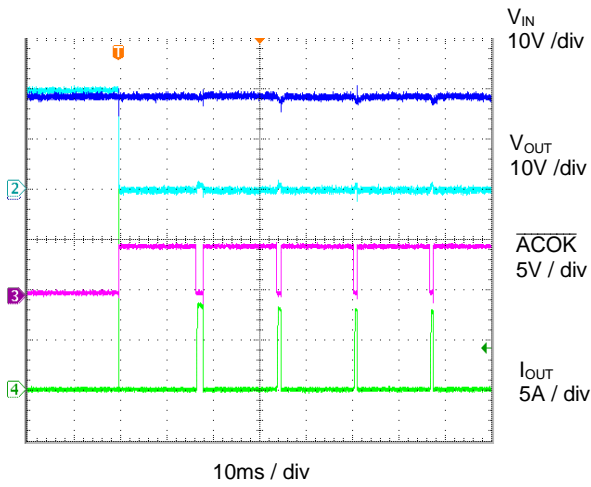

Surge Transient ($90V$)

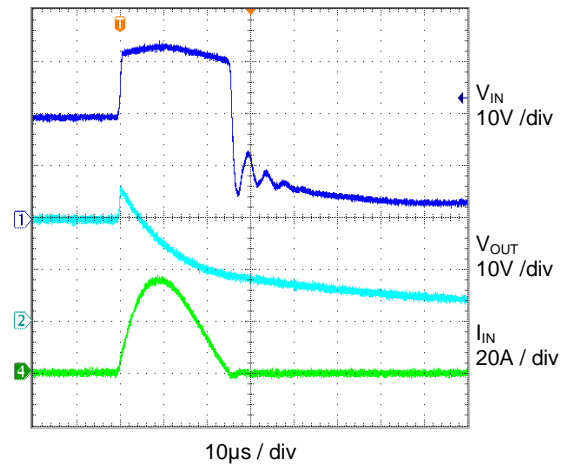

Timing Diagram

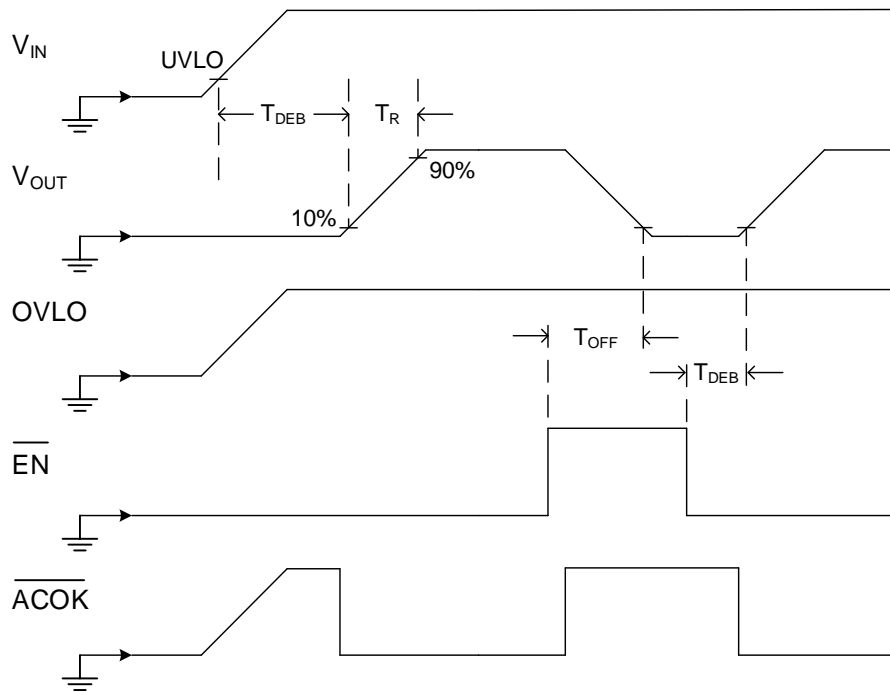

Figure 1. Ramp-up and \overline{EN} Toggling

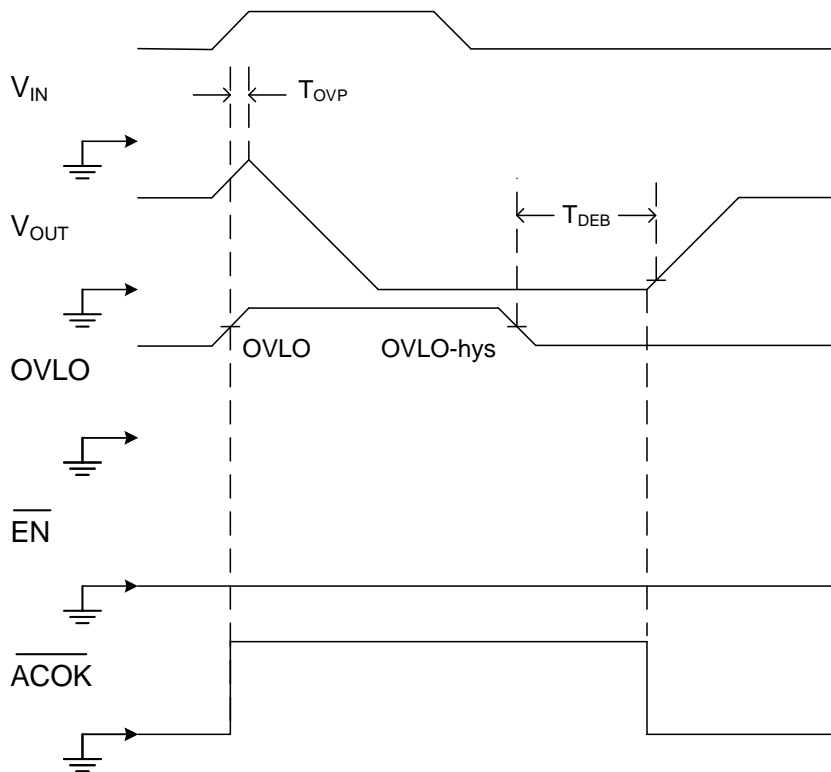

Figure 2. OVP

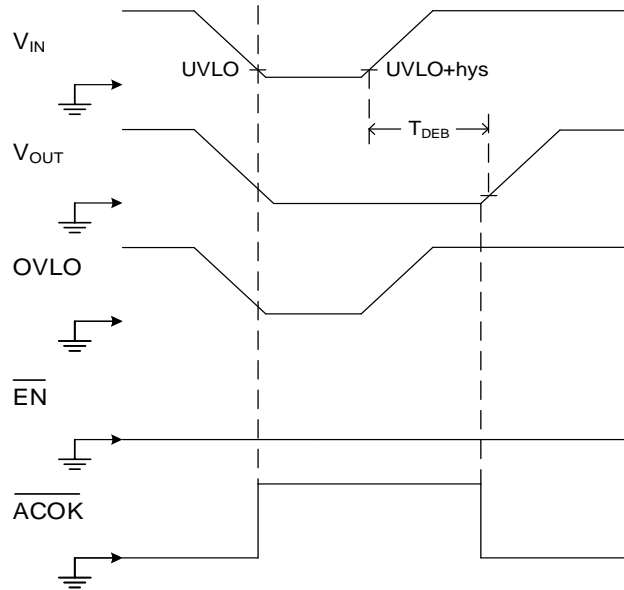

Figure 3. UVLO

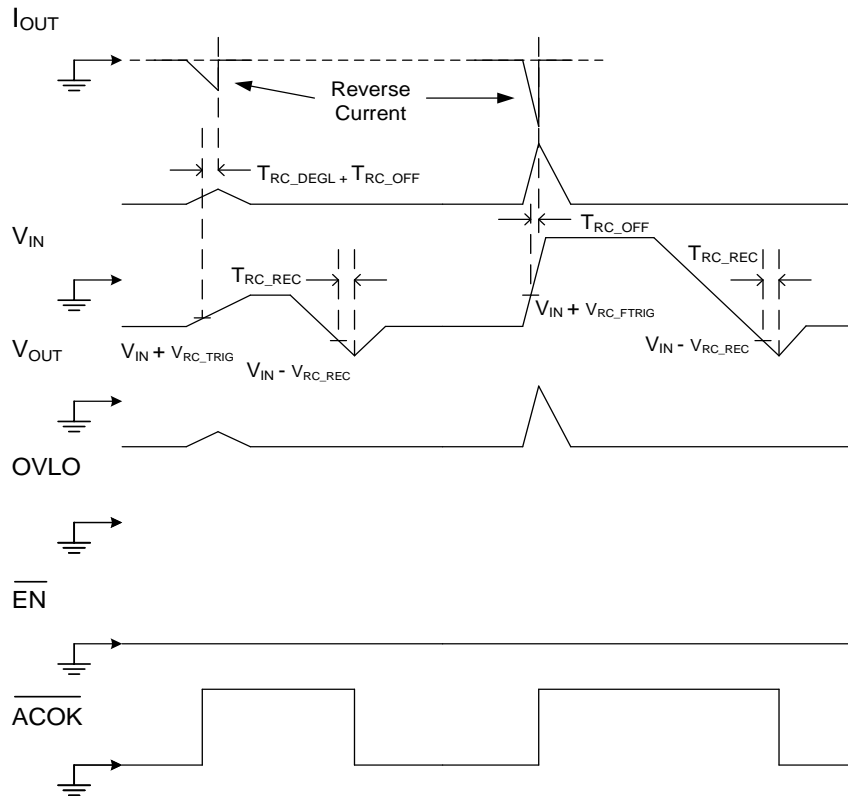

Figure 4. RCP

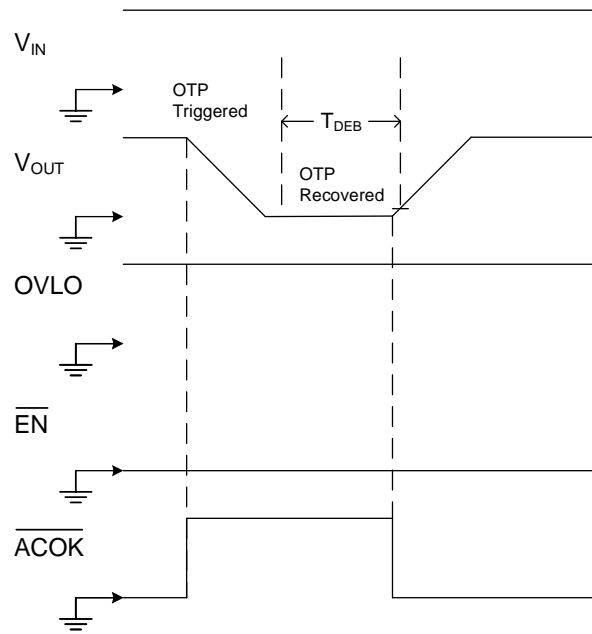

Figure 5. OTP

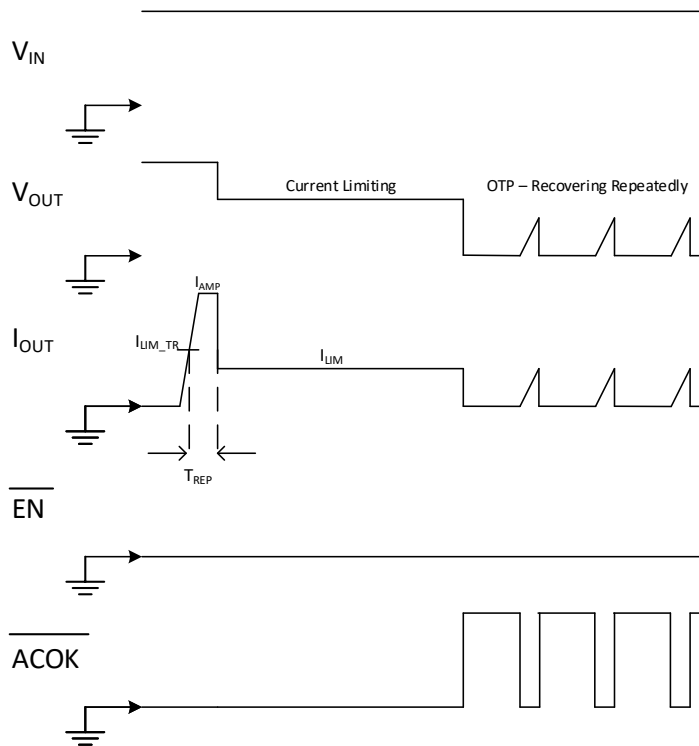
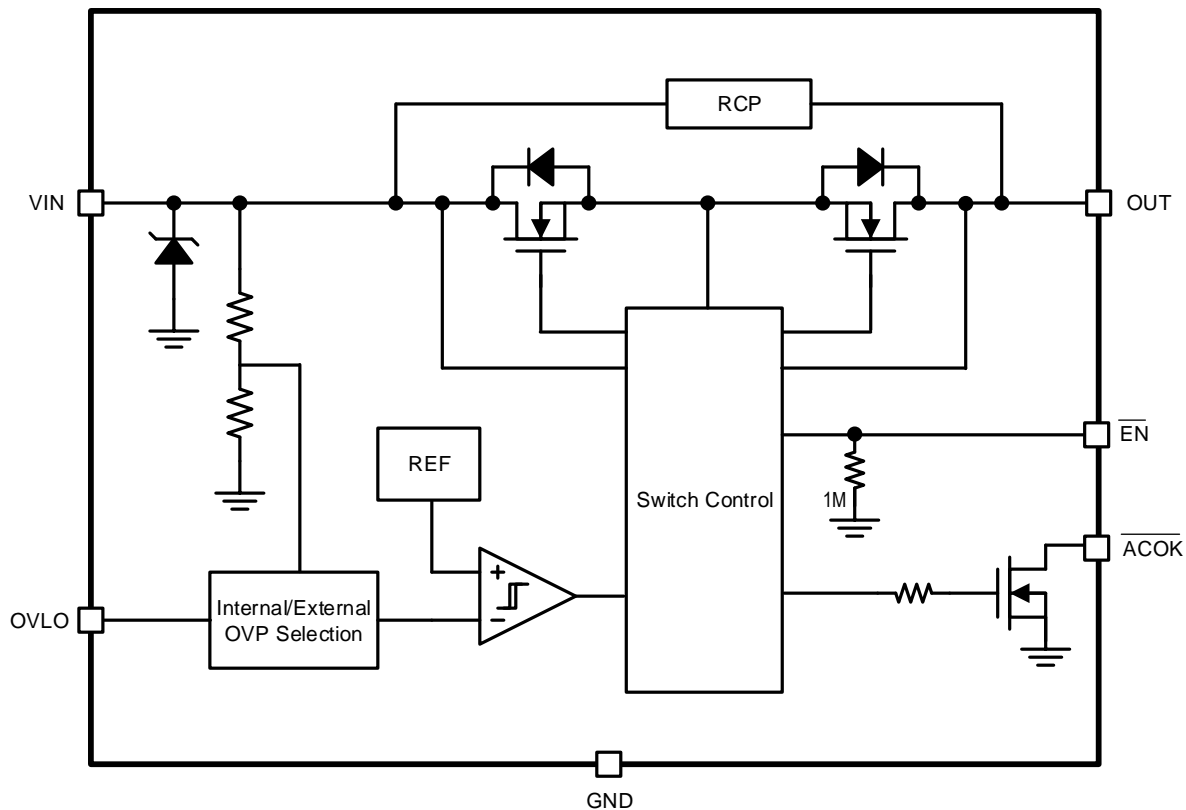

Figure 6. Current Limiting

Functional Block Diagram



Functional Description

The KTS1677A is a slew-rate controlled, 30mΩ (Typ), low resistance MOSFET switch intended to be inserted between a power source and a load to isolate and protect against abnormal voltage and current conditions. Featuring slew-rate turn-on control, to prevent excessive large inrush currents, the KTS1677A also features several additional protection functions, such as input ±90V surge, input overvoltage, input under-voltage protection, reverse current blocking, short-circuit and over-temperature protection.

Operating from a wide input voltage range of 3V to 23V the KTS1677A can cover USB PD applications to offer essential protection and enhance system reliability. The KTS1677A in the OFF state can block voltages on the VIN/VOUT pin of up to 28V and prevent reverse currents. Two KTS1677A can be used to support dual power inputs connecting to the same downstream device.

EN Input

$\overline{EN} = H$ disables the power switch and puts the device into low power mode. $\overline{EN} = L$ enables the protection circuits and the power switch. An internal 1MΩ pull-down resistor is mounted on \overline{EN} pin to ensure the power switch turns on under dead-battery situations. To ensure that the input voltage is stable, a 15 ms de-bounce time has been deployed prior to initiating device turn-on.

Under Voltage Lockout

When $\overline{EN} = L$ and $V_{IN} < V_{UVLO}$, power switch is disabled. Once V_{IN} exceeds V_{UVLO} and no other protection fault is detected, the power switch is controlled by the \overline{EN} pin.

Over Voltage Lockout

When $\overline{EN} = L$ and $V_{IN} > V_{OVLO}$, the power switch is disabled. Once V_{IN} drops below V_{OVLO} and no other protection is detected, the power switch resumes operation. OVLO pin is used to set the overvoltage threshold externally. The default overvoltage threshold is 23V when OVLO pin is tied to GND. Biasing OVLO pin with a resistor adjusts the over voltage threshold from 4V to 23V as below formula:

$$V_{BUS_OVLO_THRESHOLD} = V_{OVLO_TH} \times \left(1 + \frac{R1}{R2}\right)$$

Over-Temperature Protection

When device junction temperature exceeds 150°C the OTP circuit disables the power switch and sets the \overline{ACOK} output Hi-Z. Once the device junction temperature falls below 130°C and no other fault condition is detected, the power switch turn-on sequence is initiated and the \overline{EN} pin regains control.

Over-Current Limiting Protection

If the output is shorted to ground or heavily loaded exceeding I_{LIM_TR} , after a short time, T_{REP} , the KTS1677A limits its output current to I_{LIM} by adjusting V_{OUT} to a lower level. The resulting power dissipation increases, and accelerates the part towards thermal shutdown. If the short-circuit or heavy load is not removed, the device remains OFF until the junction temperature falls to the OTP hysteresis level and the device turns back on and thermally cycle OFF and ON, until either the fault condition is removed or $\overline{EN} = L$. See Figure 6 for more details.

\overline{ACOK} Output

The \overline{ACOK} output is an open-drain output that requires an external pull-up resistor. The \overline{ACOK} pin indicates input voltage status. When UVLO, OVLO, OTP are not triggered, and power switch is on, \overline{ACOK} is low, otherwise it stays at high impedance. The pull up resistor value is recommended to be 10kΩ to 200kΩ.

Reverse Current Protection

KTS1677A offers reverse current protection regardless of \overline{EN} status. Once the voltage on V_{OUT} is greater than V_{IN} for 80 mV, the RCP circuit is triggered after a 4.2ms de-glitch time. If the voltage difference is greater than 120 mV, RCP triggers immediately to switch off the power switch. During the startup de-bounce time, if the device detects the V_{OUT} voltage is higher than V_{IN} by 80 mV, the power switch will not be turned on. When V_{OUT} voltage falls 10mV below V_{IN} , the power switch will be turned on back again within 26ms if $\overline{EN} = L$ and other faults are not detected. The RCP circuit enables the parallel connection of two USB charging ports to a single charger input, without reverse leakage.

Applications

Input Capacitor

For most applications, connect a 1nF ceramic capacitor as close as possible to the device from IN to GND to minimize the effect of parasitic trace inductance.

OUT Output Capacitor

The internal soft-start function allows the KTS1677A to charge an output capacitor up to 1000 μ F without turning off due to overcurrent. As a minimum it is recommended to bypass OUT with a 1 μ F ceramic capacitor.

Layout Recommendation

To minimize the resistance in series with the switch, all VIN and VOUT pads should be connected together on the PCB with wide traces to handle the large current and also improve the IC thermal dissipation. All GND pads should be connected together directly to the GND plane. This is important for best protection during surge transient.

The input and output capacitors should be placed as close as possible to the IC.

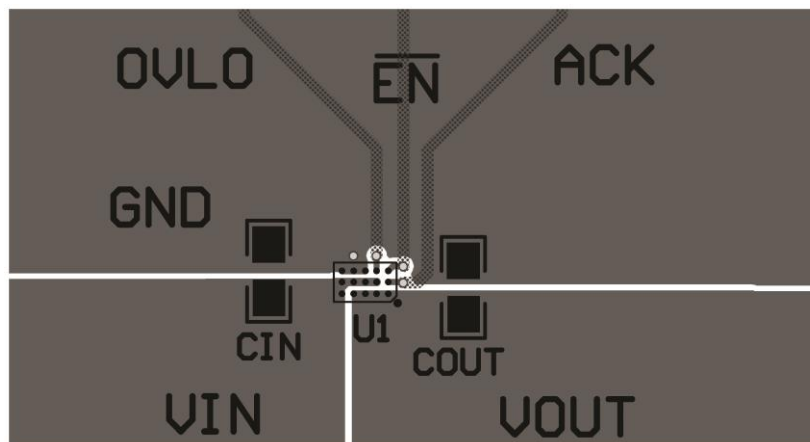

Figure 7. Recommended PCB Layout for WLCSP53-15 Package

Application Example

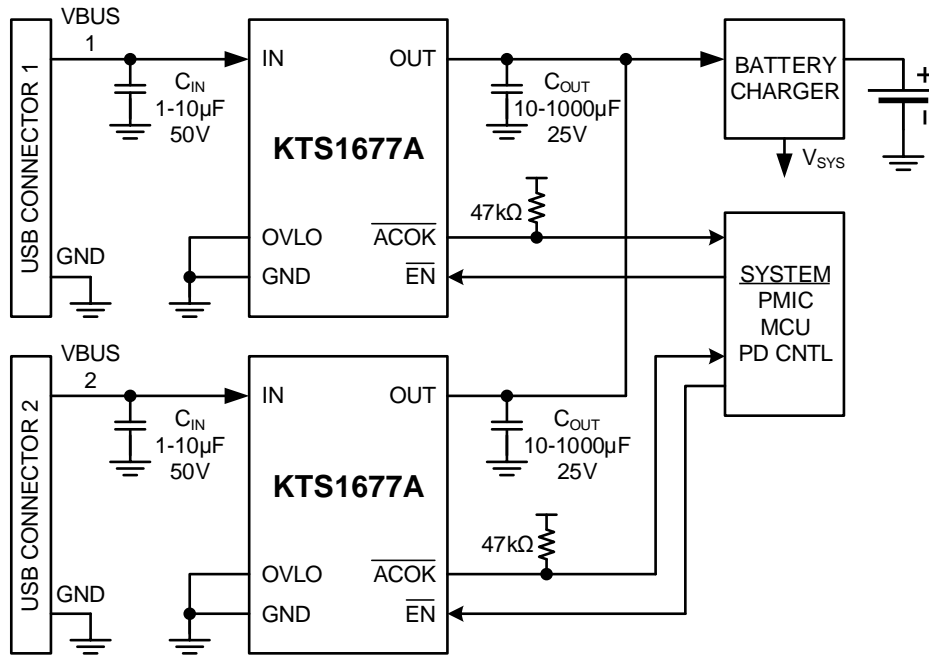
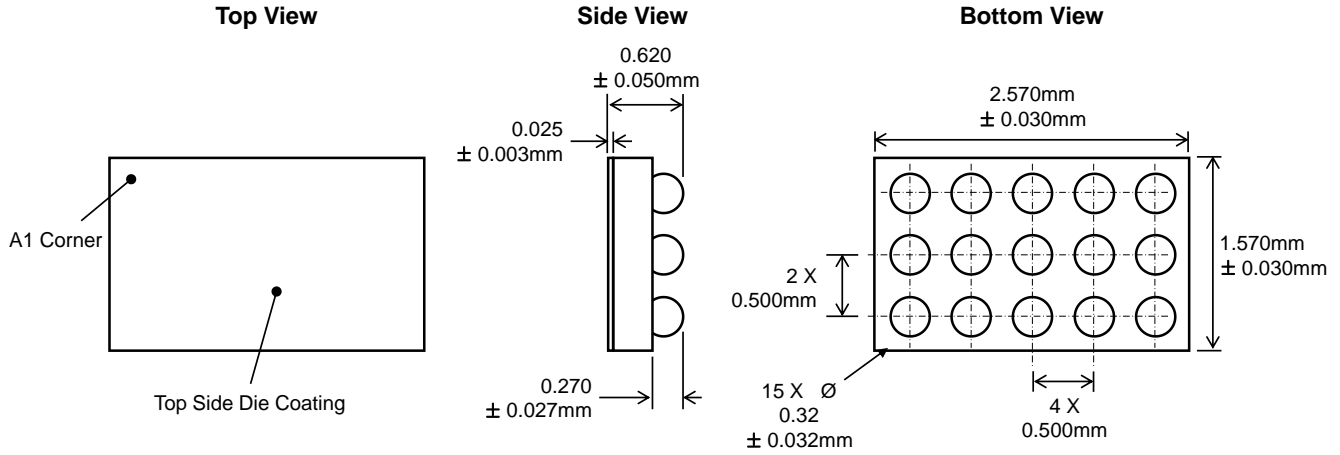

Figure 8. Two Input USB Adapter Configuration

In Figure 8, two KTS1677A are used to select the power from one of two potential USB supplies, while providing protection on both ports. The reverse blocking feature of the KTS1677A prevents VBUS 1 voltage appearing at VBUS 2 and vice-versa.

Packaging Information

WLCSP53-15 (2.570mm x 1.57mm x 0.620mm)



Recommended Footprint

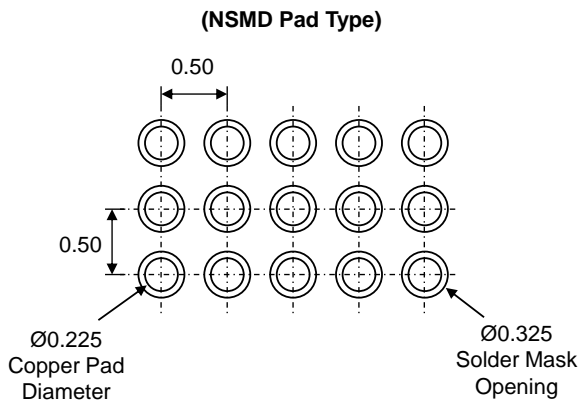

* Dimensions are in millimeters.

Kinetic Technologies cannot assume responsibility for use of any circuitry other than circuitry entirely embodied in a Kinetic Technologies product. No intellectual property or circuit patent licenses are implied. Kinetic Technologies reserves the right to change the circuitry and specifications without notice at any time.

X-ON Electronics

Largest Supplier of Electrical and Electronic Components

Click to view similar products for [Power Management IC Development Tools](#) *category:*

Click to view products by [Kinetic Technologies](#) *manufacturer:*

Other Similar products are found below :

[EVB-EP5348UI](#) [BQ25010EVM](#) [ISL80019AEVAL1Z](#) [ISLUSBI2CKIT1Z](#) [ISL8002AEVAL1Z](#) [ISL91108IIA-EVZ](#) [MAX8556EVKIT](#)
[MAX15005AEVKIT+](#) [ISL28022EVKIT1Z](#) [STEVAL-ISA008V1](#) [DRI0043](#) [KITPF8100FRDMEVM](#) [EVB-EN6337QA](#)
[SAMPLEBOXILD8150TOBO1](#) [MAX18066EVKIT#](#) [AP62300WU-EVM](#) [KITA2GTC387MOTORCTRTOBO1](#) [AEK-MOT-TK200G1](#)
[EVLONE65W](#) [STEVAL-ILH006V1](#) [STEVAL-IPE008V2](#) [STEVAL-IPP001V2](#) [STEVAL-ISA013V1](#) [STEVAL-ISA067V1](#) [STEVAL-](#)
[ISQ002V1](#) [TPS2306EVM-001](#) [TPS2330EVM-185](#) [TPS40001EVM-001](#) [SECO-HVDCDC1362-15W-GEVB](#) [BTS7030-2EPA](#)
[LT8638SJV#WPBF](#) [LTC3308AIV#WTRPBF](#) [TLT807B0EPV](#) [BTS71033-6ESA](#) [EV13N91A](#) [EASYPIC V8 OVER USB-C](#) [EV55W64A](#)
[CLICKER 4 FOR STM32F4](#) [EASYMX PRO V7A FOR STM32](#) [CLICKER 4 FOR PIC18F](#) [Si8285_86v2-KIT](#) [PAC52700EVK1](#) [NCP-](#)
[NCV51752D2PAK3LGEVB](#) [ISL81807EVAL1Z](#) [AP33772S-EVB](#) [EVALM7HVIGBTFCINV4TOBO1](#) [903-0300-000](#) [902-0173-000](#) [903-](#)
[0301-000](#) [ROA1286023/1](#)