

Low R_{ON} Load Switch with Overvoltage and Reverse Blocking Protection

Features

- Wide Input voltage range: 3V to 23V
- 30V Absolute Ratings at V_{IN} and V_{OUT}
- Maximum 5A continuous current
- Integrated FET with 30m Ω (Typ) R_{ON}
- Wide Overvoltage threshold range
 - Fixed internal: 23V
 - Adjustable: 4V to 23V
- Open-Drain power good indicator
- Integrated protection
 - Thermal Shutdown
 - Under-Voltage Lockout (UVLO)
 - Overvoltage Lockout (OVLO)
 - V_{OUT} to V_{IN} Reverse Current Blocking
 - Over-current limiting
- Surge and ESD Protection
 - IEC61000-4-5: $\pm 90V$ for V_{IN}
 - IEC61000-4-2: $\pm 8KV$ Contact, $\pm 15KV$ Air for V_{IN}
 - HBM: $\pm 2KV$ for all Pins
- Pb-free Package:
 - 15 Bump WLCSP 2.57mm x 1.57mm
- -40°C to +85°C Temperature Range

Brief Description

The KTS1677A is a slew-rate controlled, 30m Ω (Typ), low resistance MOSFET switch intended to be inserted between a power source and a load to isolate and protect against abnormal voltage and current conditions. Featuring slew-rate turn on control, to prevent excessive large inrush current, the KTS1677A also features several additional protection functions, such as input $\pm 90V$ surge, input overvoltage, input under-voltage protection, reverse current blocking, over-current limiting and over-temperature protection.

Operating from a wide input voltage range of 3V to 30V can cover USB PD applications to offer essential protection and enhance system reliability. The KTS1677A in the OFF state can block voltages on the V_{IN}/V_{OUT} pin of up to 30V and prevent reverse currents. Two KTS1677A can be used in to support dual power inputs connecting to the same downstream device.

The device is packaged in advanced, fully “green” compliant, 2.57mm x 1.57mm, Wafer-Level Chip-Scale Package (WLCSP).

Applications

- Computers and Tablets
- Mobile Internet Devices
- Type-C Power Source Switch
- Storage, DSLR and Portable Devices

Typical Application

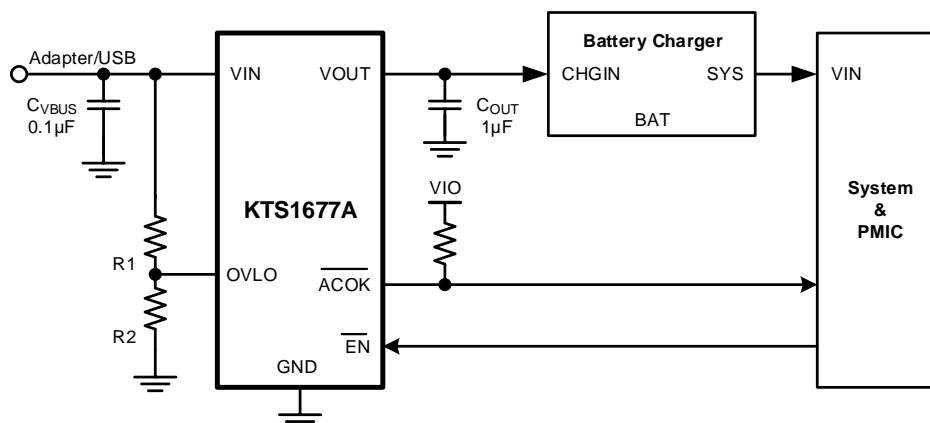

Ordering Information

Part Number	Marking	Operating Temperature	Package
KTS1677AEVH-TR	NBXXYYZZZZ	-40°C to +85°C	WLCSP-15

1. "WWXXYYZZZZ" is the mark code, date code and assembly code.

X-ON Electronics

Largest Supplier of Electrical and Electronic Components

Click to view similar products for [Power Switch ICs - Power Distribution](#) *category:*

Click to view products by [Kinetic Technologies](#) *manufacturer:*

Other Similar products are found below :

[TCK111G,LF\(S\)](#) [FPF1018](#) [DS1222](#) [TCK2065G,LF](#) [SZNCP3712ASNT3G](#) [MIC2033-05BYMT-T5](#) [MIC2033-12AYMT-T5](#) [MIC2033-05BYM6-T5](#) [SLG5NT1437VTR](#) [SZNCP3712ASNT1G](#) [DML1008LDS-7](#) [KTS1670EDA-TR](#) [KTS1640QGDV-TR](#) [KTS1641QGDV-TR](#) [NCV459MNWTBG](#) [FPF2260ATMX](#) [U6513A](#) [U6119S](#) [MIC2012YM-TR](#) [MAX14919ATP+](#) [MC33882PEP](#) [TPS2021IDRQ1](#) [TPS2104DBVR](#) [MIC2098-1YMT-TR](#) [MIC94062YMT TR](#) [MP6231DN-LF](#) [MIC2075-2YM](#) [MIC2095-2YMT-TR](#) [MIC94068YML-TR](#) [SIP32461DB-T2-GE1](#) [NCP335FCT2G](#) [TCK105G,LF\(S\)](#) [AP2151DSG-13](#) [MIC94094YC6-TR](#) [MIC94064YC6-TR](#) [MIC2505-1YM](#) [MIC94305YMT-TR](#) [MIC94081YFT-TR](#) [MIC94042YFL-TR](#) [MIC94041YFL-TR](#) [MIC2005-1.2YM6-TR](#) [TPS2032QDRQ1](#) [SIP32510DT-T1-GE3](#) [NCP333FCT2G](#) [NCP331SNT1G](#) [TPS2092DR](#) [TPS2063DR](#) [TPS2042P](#) [MIC2008YML-TR](#) [MIC2040-1YMM](#)