

Overvoltage Protector with Bidirectional Blocking and Surge Protection

Features

- Wide Input voltage range: 3.0V to +28V
- Integrated typical 65mΩ N-Channel MOSFET
- 4.5A Continuous Current
- Wide Over-Voltage threshold range
 - ▶ Adjustable: 5V to 22V
 - ▶ Fixed: 5.885V ± 3%
- Fast Over-Voltage response time 100ns
- Start-up Debounce time : 20ms (typ.)
- Low Quiescent Current : 140μA (typ.)
- Integrated Protection
 - ▶ Thermal Shutdown
 - ▶ Under voltage protection (UVLO)
 - ▶ Soft-Start
 - ▶ OUT to IN Reverse Blocking
- Open-drain & Logic Output Power Good pins
- Integrated Surge Protection up to +100V
- Pb-free Package:
 - ▶ 15-Bump WLCSP 1.6mm x 2.1mm
- -40°C to +85°C Temperature Range

Applications

- Smartphones and Tablets
- Mobile Internet Devices
- Peripherals, E-Readers

Brief Description

The KTS1686 over-voltage protection device features high current integrated N-Ch MOSFETs with an ultra-low IN to OUT on-resistance of 65mΩ (typical), actively protecting low-voltage systems from voltage supply faults up to +28VDC. An internal clamp protects the device from surges up to +100V.

An input voltage exceeding the over-voltage threshold will cause the internal MOSFET to turn off, preventing excessive voltage from damaging downstream devices.

When the OVLO input set below the external OVLO select voltage, the KTS1686 automatically chooses the internal fixed OVLO threshold, preset to 5.885V (typical). The over-voltage protection threshold can be adjusted with optional resistor divider to a voltage between 5V and 22V.

The KTS1686 also features reverse bias blocking, preventing any voltage present at OUT not feeding back into IN when the device is in the OFF state. When OTG_EN is high, the path from OUT to IN is enabled, to permit the powering of external OTG peripherals.

The KTS1686 also features additional protection including enhanced ESD protection and thermal protection to protect against over-load conditions.

The KTS1686 is available in a RoHS and Green compliant 15-Bump WLCSP 1.6mm x 2.1mm WLCSP.

Typical Application

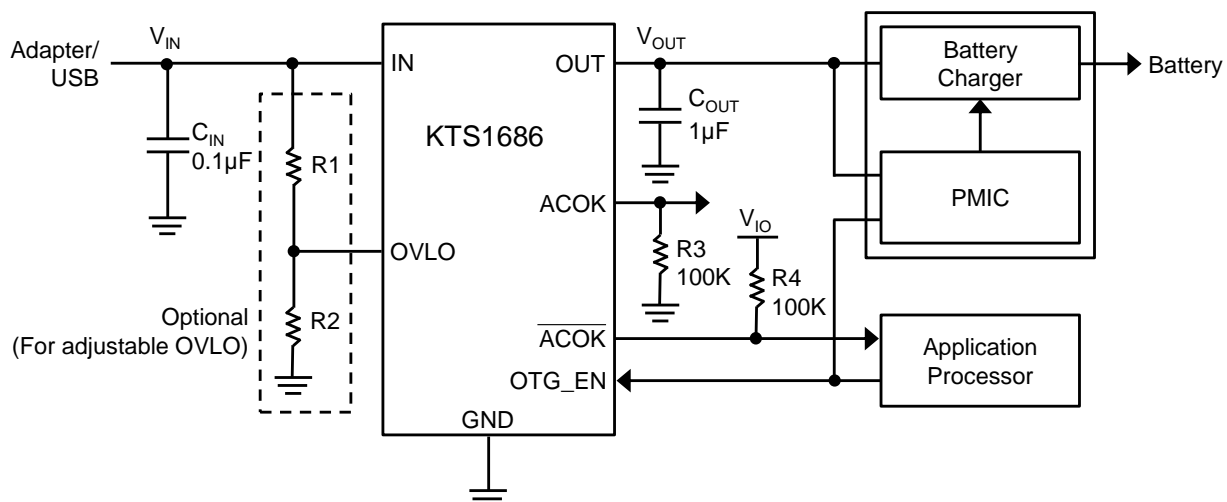

Pin Descriptions

Pin #	Name	Function
A1-A4, B1	OUT	Output of internal main high-current power switch. Connect all OUT pins together in the PCB for correct operation. Bypass OUT with a 1µF ceramic capacitor.
A5	OTG_EN	Active high enable input for OTG operation mode.
B2, C1-C4	IN	Over-voltage Protected Input. Connect all OUT pins together in the PCB for correct operation. Bypass IN with 0.1µF ceramic capacitor as close as possible to the device.
B3	ACOK	1.8V Logic Output. ACOK is driven high after input voltage is stable between minimum VIN and VOVLO when OTG_EN = 0. Connect a pulldown resistor from ACOK to ground.
B4	OVLO	External OVLO adjustment. Connect OVLO to GND when using the internal threshold. Connect a resistor-divider to OVLO to set a different OVLO threshold.
B5	$\overline{\text{ACOK}}$	Open-Drain Flag Output. $\overline{\text{ACOK}}$ is driven low after input voltage is stable between minimum VIN and VOVLO when OTG_EN = 0. Connect a pull-up resistor from $\overline{\text{ACOK}}$ to the logic I/O voltage of the host system.
C5	GND	Ground.

WLCSP-15, 1.6mm x 2.1mm

15-Bump 1.6mm x 2.1mm x 0.640mm
 WLCSP Package
 YYZZ (Date Code and Assembly Code)
 XX = Device Code (Top Mark)

(Top View)

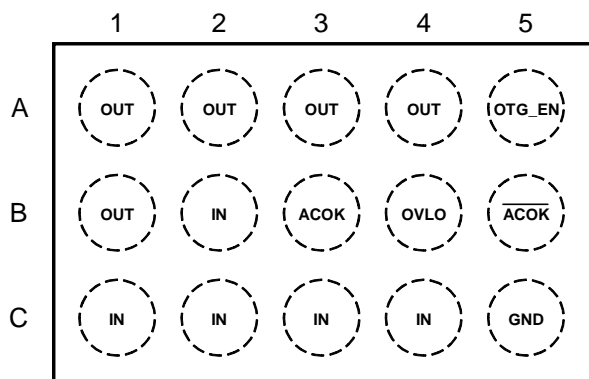

(Top View)

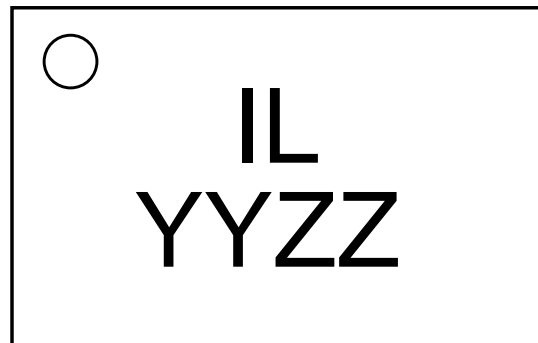

Absolute Maximum Ratings¹

(T_A = 25°C unless otherwise noted)

Symbol	Description	Value	Units
IN ²	Input Voltage	-0.3 to 29	V
OUT	Output Voltage	-0.3 to 26	V
IN-OUT	IN to OUT Voltage (when OFF)	-26 to 29	V
OVLO	OVLO	-0.3 to 7	V
OTG_EN, ACOK, $\overline{ACO\bar{K}}$	Enable and Flag pins	-0.3 to 6	V
IN, OUT Current ³	Continuous Current	4.5	A
T _J	Operating Temperature Range	-40 to 150	°C
T _s	Storage Temperature Range	-65 to 150	°C
T _{LEAD}	Maximum Soldering Temperature (at leads, 10 sec)	260	°C

Thermal Capabilities

Symbol	Description	Value	Units
θ_{JA}	Thermal Resistance – Junction to Ambient ³	52	°C/W
P _D	Maximum Power Dissipation at T _A ≤ 70°C	1300	mW
$\Delta P_D/\Delta T$	Derating Factor Above T _A = 70°C	16.4	mW/°C

Recommended Operating Range

Description	Value
Input Voltage Range	3.0V to 28V

Ordering Information

Part Number	Marking ⁴	Operating Temperature	Package
KTS1686EUF-TR	ILYYZZ	-40°C to +85°C	WLCSP-15

- Stresses above those listed in Absolute Maximum Ratings may cause permanent damage to the device. Functional operation at conditions other than the operating conditions specified is not implied. Only one Absolute Maximum rating should be applied at any one time.
- Survives burst pulse up to 100V with 2Ω series resistance.
- Junction to Ambient thermal resistance is highly dependent on PCB layout. Values are based on thermal properties of the device when soldered to an EV board.
- "YYZZ" is the date code and assembly code.

Electrical Characteristics⁵

$V_{IN} = +3.0V$ to $+28V$, $V_{OUT} = 3V$ to $+24V$. Unless otherwise noted, the *Min* and *Max* specs are applied over the full operation temperature range of $-40^{\circ}C$ to $+85^{\circ}C$, while *Typ* values are specified at room temperature ($25^{\circ}C$). $V_{IN} = 5V$.

Symbol	Description	Conditions	Min	Typ	Max	Units
INPUT						
V_{INSU}	Input start-up voltage			2.3	3	V
V_{INST}	Input sustaining voltage	$I_{OUT} = 0A$		1.9	2.3	V
V_{IN_CLAMP}	Input clamp voltage	$I_{IN} = 10mA$, $T_A = +25^{\circ}C$		32		V
I_{IN}	Input supply current	$V_{IN} = 5V$, $V_{OVLO} = 0V$, $V_{OTG_EN} = 0V$ $ACOK = Open$, $I_{OUT} = 0mA$		140	190	μA
V_{OUTSU}	Output start-up voltage			2.3	3.0	V
V_{OUTST}	Output sustaining voltage	$I_{IN} = 0A$		1.9	2.3	V
I_{OUT}	Output supply current	$V_{OVLO} = 0V$, $V_{OUT} = 5V$, $I_{IN} = 0mA$, $V_{OTG_EN} = 1.8V$		133	170	μA
I_{OUTSD}	Output shutdown current	$V_{OVLO} = 3V$, $V_{OUT} = 5V$, $V_{IN} = 0V$, $V+ = 0V$		6	12	μA
I_{IN_LEAK}	IN leakage current	$V_{OUT} = 21V$, IN Open, $V_{OTG_EN} = 0V$			0.1	V
I_{IN_DIS}	IN discharge current	$V_{IN} = V_{OUT} = 5V$, IN discharge current following a high to low OTG_EN transition		90	150	mA
OVP (IN to OUT)						
V_{IN_OVLO}	Internal over voltage trip level	V_{IN} rising	5.71	5.885	6.06	V
		V_{IN} falling	5.61			V
V_{OVLO_TH}	OVLO preset threshold range		1.18	1.221	1.26	V
	Adjustable OVLO threshold range		5		22	V
V_{OVLO_SEL}	External OVLO select threshold		0.2	0.25	0.3	V
$R_{DS(ON)}$	Switch On-Resistance (IN to OUT)	$V_{IN} = 5V$, $I_{IN} = 100mA$, $T_A = +25^{\circ}C$		65	82	m Ω
Digital Signals (ACOK, ACOK, OTG_EN)						
V_{OL}	ACOK output low voltage	$V_{IO} = 3.3V$, $I_{SINK} = 1mA$			0.4	V
I_{ACOK_LEAK}	ACOK leakage current	$V_{IO} = 3.3V$, ACOK de-asserted			1	μA
V_{ACOK}	ACOK output high voltage	$I_{SOURCE} \leq 100\mu A$, $V_{IN} > 3V$	1.6	1.8	2.0	V
I_{ACOK_LEAK}	ACOK leakage current	Pull-down to GND, $V_{OUT} = 5V$, $OTG_EN = High$, ACOK de-asserted			1	μA
V_{IH}	OTG_EN input logic High		1.6			V
V_{IL}	OTG_EN input logic Low				0.4	V
I_{IN}	OTG_EN input leakage current	$0V \leq V_{IN} \leq V_{IL}$ and $V_{IH} \leq V_{IN} \leq V_{CC}$, $V_{CC} = 5.5V$	-1		+1	μA

5. KTS1686 is guaranteed to meet performance specifications over the $-40^{\circ}C$ to $+85^{\circ}C$ operating temperature range by design, characterization and correlation with statistical process controls.

Electrical Characteristics⁵

Symbol	Description	Conditions	Min	Typ	Max	Units
TIMING CHARACTERISTICS						
t _{DEB}	Debounce time	V _{IN} = 5V to V _{OUT} rising, (V _{OUT} = 10% of V _{IN}), R _L = 100Ω, C _L = 10μF		20		ms
t _{ON}	Switch turn-on time during Soft-start	V _{IN} = 5V, V _{OUT} from 20% of V _{IN} to 80% of V _{IN} , R _L = 100Ω, C _L = 10μF		1.5		ms
t _{OFF}	Switch turn-off response time	V _{IN} > V _{OVLO} to V _{OUT} = 80% of V _{IN} , R _L = 100Ω, V _{IN} rising at 2V/μs		100		ns
t _{OTG_ON}	OTG Turn-on time	Time from OTG_EN high to V _{IN} = 80% of V _{OUT} . V _{OUT} = 5V, C _{IN} = 10μF		1.4		ms
t _{IN_DIS}	Pulse Duration of IN Discharge	V _{IN} = V _{OUT} = 5V, discharge pulse duration following OTG_EN transitioning from High to Low		1.1		ms
ESD PROTECTION (IEC61000-4-2)						
V _{ESD}	Human Body Model (HBM)	IN pin		±15		kV
	IEC61000-4-2 Contact discharge	IN pin		±8		kV
	IEC61000-4-2 Air gap discharge	IN pin		±8		kV
Thermal Shutdown						
t _{J-TH}	IC junction thermal shutdown threshold			150		°C
	IC junction thermal shutdown hysteresis			25		°C

5. KTS1686 is guaranteed to meet performance specifications over the -40°C to +85°C operating temperature range by design, characterization and correlation with statistical process controls.

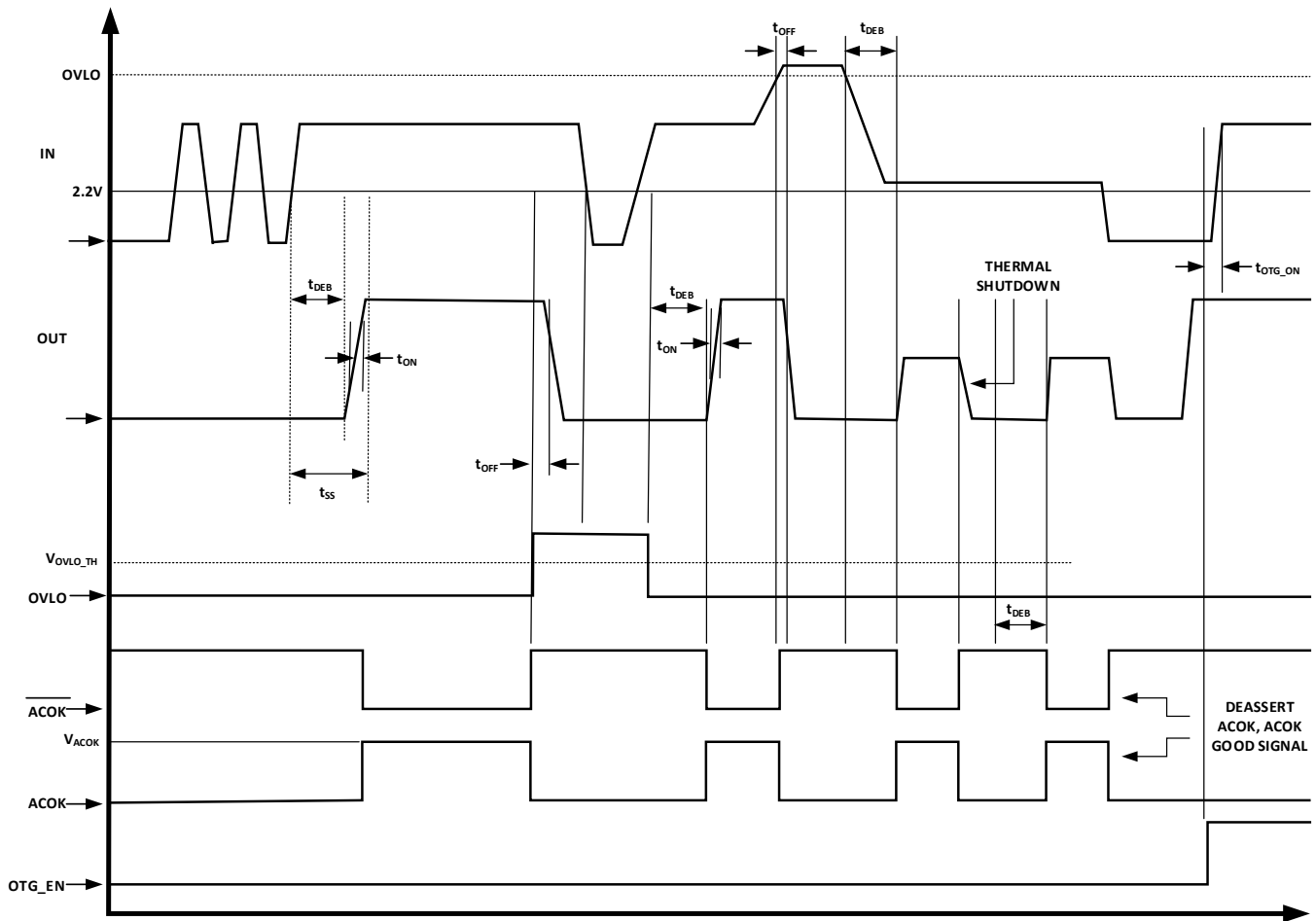
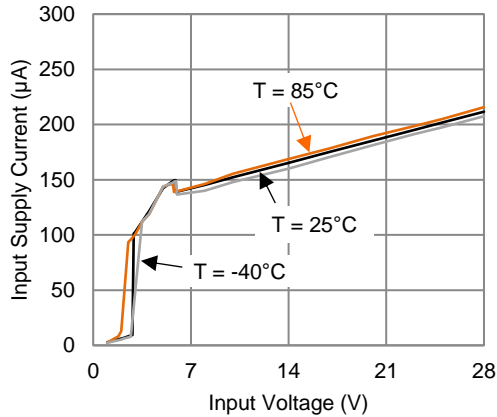

Figure 1. Timing Diagram

Typical Characteristics

$V_{IN} = 5V$, $C_{IN} = 0.1\mu F$, $C_{OUT} = 1\mu F$, OVLO pin = GND, Temp = 25°C unless otherwise specified.

Input Supply Current vs. Input Voltage (no load)



Output Supply Current vs. Output Voltage (no load)

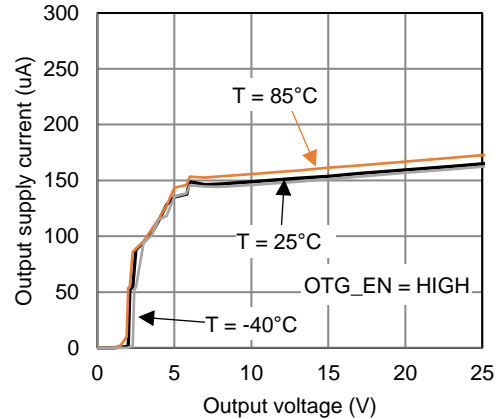

Normalized RDSON vs. Output Current

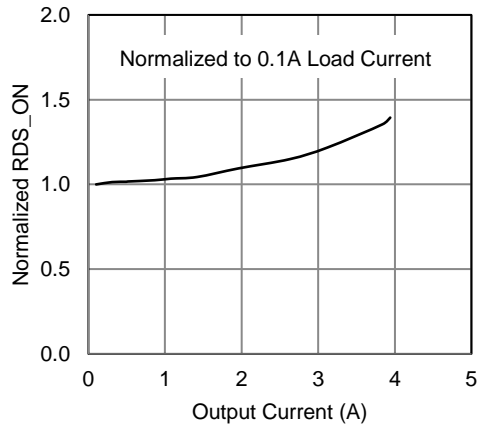

Normalized RDSON vs. Temperature

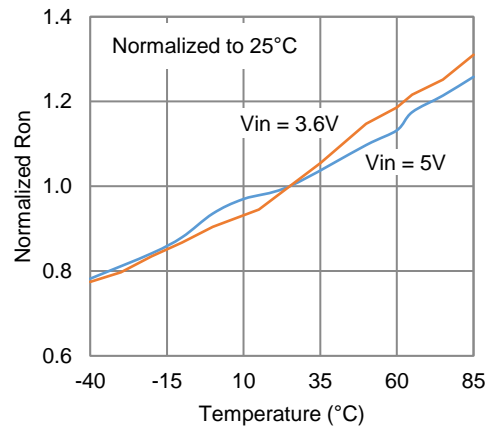

Output Shutdown Current vs. Out Voltage

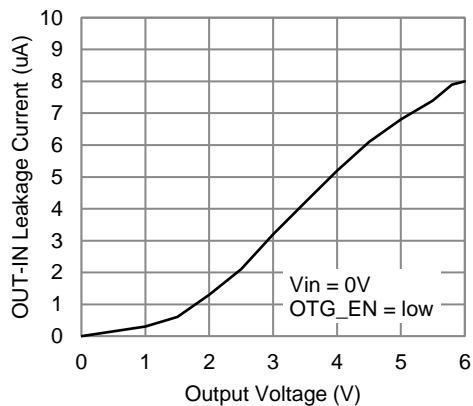

Typical Characteristics (continued)

$V_{IN} = 5V$, $C_{IN} = 0.1\mu F$, $C_{OUT} = 1\mu F$, OVLO pin = GND, Temp = 25°C unless otherwise specified.

Normalized Internal OVLO Threshold vs. Temperature

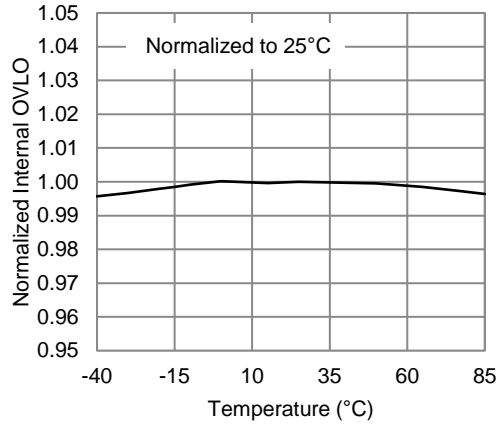

Normalized External OVLO Set Threshold vs. Temperature

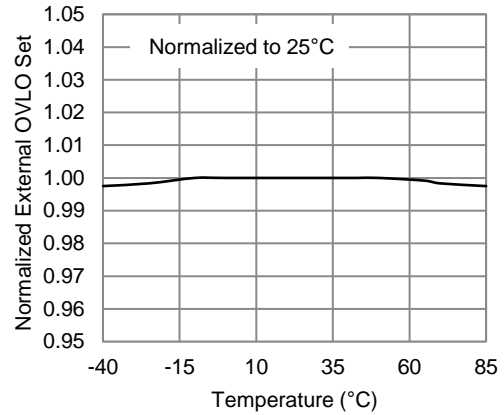

Normalized External OVLO Select Threshold vs. Temperature

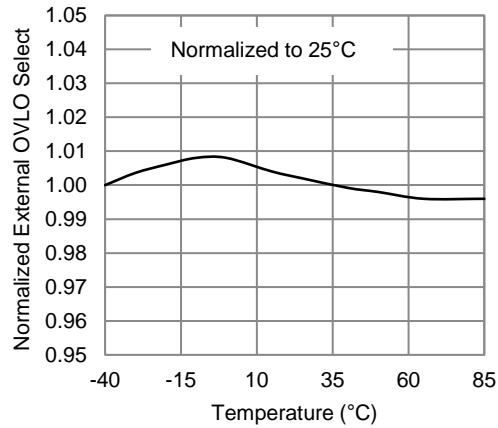

Normalized Debounce Time vs. Temperature

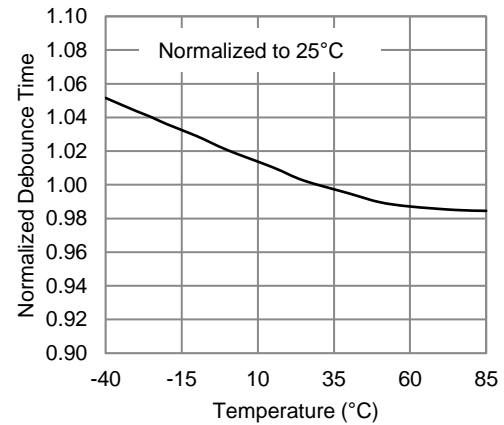

Typical Characteristics (continued)

$V_{IN} = 5V$, $C_{IN} = 0.1\mu F$, $C_{OUT} = 1\mu F$, OVLO pin = GND, Temp = 25°C unless otherwise specified.

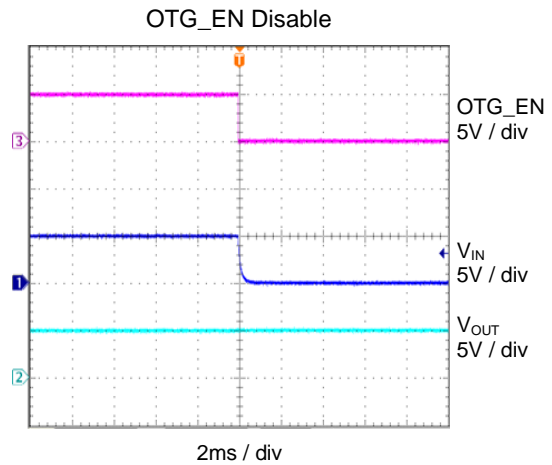
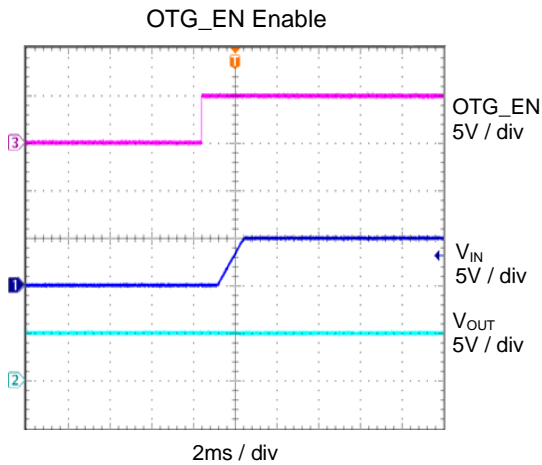
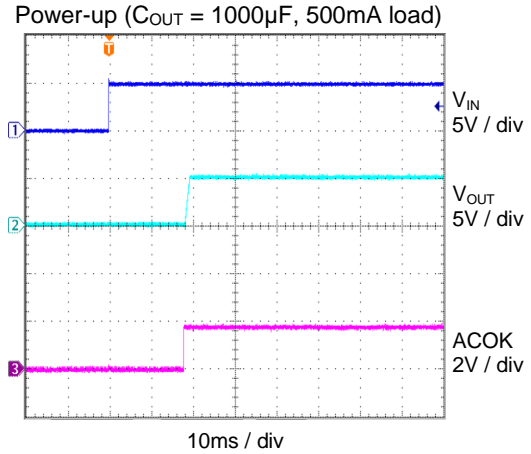
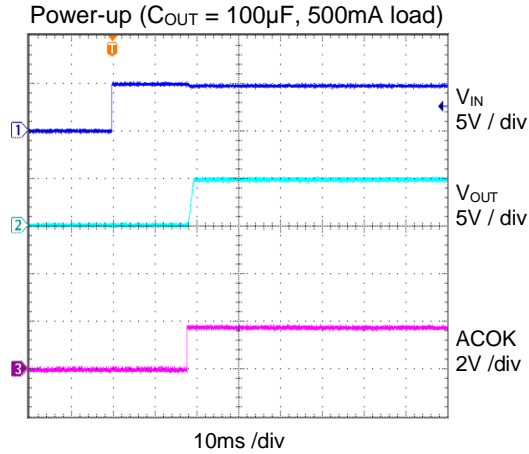

Over Voltage Fault Protection (V_{IN} 5V to 9V step)

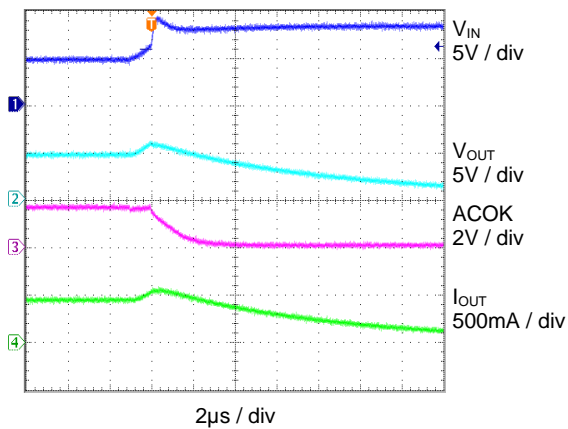

Surge Transient (100V)

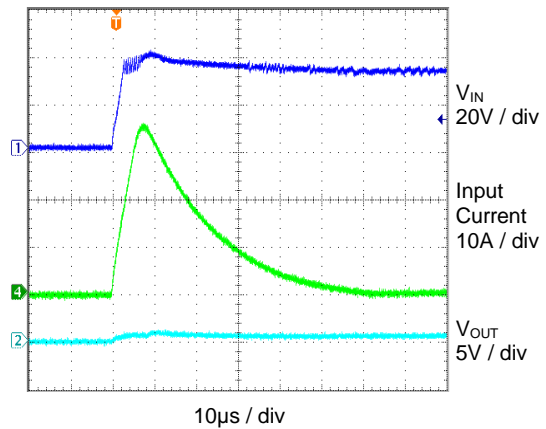

Functional Block Diagram

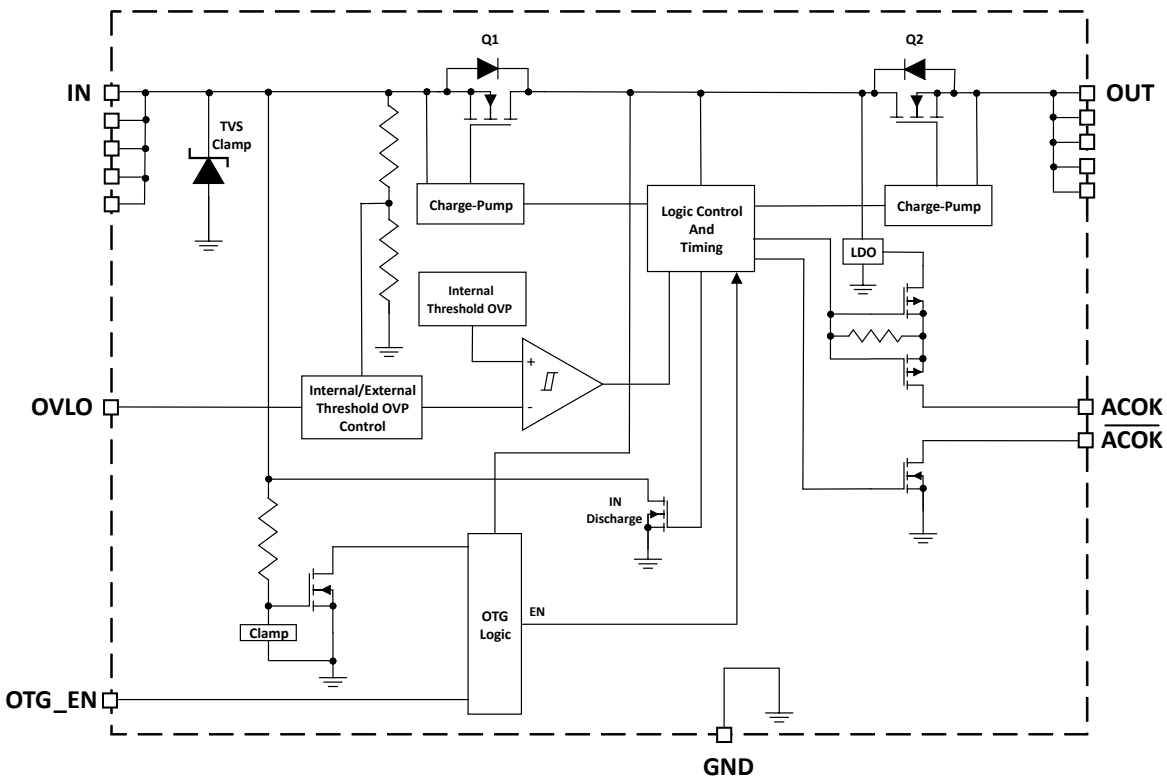

Functional Description

The KTS1686 is inserted between the power supply or charger source and the load to be protected. The KTS1686 consists of two “back-to-back” low resistance OVP MOSFET switches, under-voltage lockout protection (UVLO), over-voltage monitor and protection (OVLO), and power good output flags.

The KTS1686 overvoltage protection devices features low on-resistance ($R_{DS(ON)}$) internal FETs and protect low-voltage systems against voltage faults up to +28VDC. An internal clamp also protects the devices from surges up to +100V. If the input voltage exceeds the overvoltage threshold, the internal FET are turned off to prevent damage to the protected components. A 20ms debounce time built into the device prevents false turn on of the internal FET during startup. The KTS1686 also supports OTG mode where both MOSFETs can be turned-on to provide current flow from OUT to IN. With OTG_EN de-asserted and the OVP switches OFF, the KTS1686 will block any voltage at OUT appearing at IN.

Over-voltage Protection

In normal operation the OVP switch acts as a slew-rate controlled load switch, connecting and disconnecting the power supply from IN to OUT. Soft-start begins when $\overline{ACOK}/\overline{ACOK}$ is asserted and ends after approximately 15ms. Two low resistance N channel MOSFETs are used to minimize the voltage drop between the voltage source and the load and to reduce the power dissipation. If OUT is greater than IN, then these MOSFETS, when in the OFF state, will block, preventing current flow from OUT to IN.

When the voltage on the input exceeds the programmed over-voltage trip point, the device immediately turns off the internal OVP switch disconnecting the load from the abnormal voltage, preventing damage to any downstream components. Simultaneously, \overline{ACOK} and \overline{ACOK} are de-asserted. When IN drops below the V_{IN_OVLO} , the de-bounce circuitry starts counting again. After the de-bounce time, the switch is turned back on and $\overline{ACOK}/\overline{ACOK}$ is asserted.

Soft-start

To minimize in-rush currents the KTS1686 features soft-start circuitry that slowly turns on MOSFETS Q1 and Q2. The soft-start time begins when $\overline{\text{ACOK}}/\text{ACOK}$ is asserted.

OVLO (Over Voltage Lockout)

The KTS1686 can be configured for either an internal OVLO threshold, or an adjustable threshold when using the OVLO pin as a sense pin. By connecting the OVLO pin to ground, the internal OVLO comparator uses the internally fixed OVLO value $V_{\text{IN_OVLO}}$ of 5.885V typical. The adjustable threshold uses a 1.221V (typical) overvoltage trip threshold on the OVLO pin. With a resistor divider on the OVLO pin from IN to GND, the overvoltage protection point of IN can be adjusted between 5V and 22V. Once the OVLO pin voltage exceeds the OVLO select voltage, $V_{\text{OVLO_SEL}}$ (0.25V typical), the comparator reads the OVLO pin voltage (a fraction of IN) set by the external resistor divider (R_1 , R_2). A high resistance R_1 value (around 1M Ω) is ideal in order to minimize the current consumption. The resistor ratio R_1/R_2 can be calculated from the following formula:

$$V_{\text{IN_OVLO}} = V_{\text{OVLO_TH}} \times \left(1 + \frac{R_1}{R_2}\right)$$

The external resistor-divider is completely independent from the internal resistive-divider.

Reverse Bias Blocking

The KTS1686 features reverse bias blocking. When the voltage at IN is below the input start-up voltage and OTG_EN is LOW, the switch between IN and OUT is open and the internal diodes of the two MOSFET switches are back-to-back, thereby blocking any reverse current. This is also true when the device is in OVP mode.

OTG Enable

The KTS1686 is OTG compatible and can be operated in the reverse direction to power OTG accessories via IN. The OTG_EN can be used to turn on both switches to allow conduction from OUT to IN, assuming that the voltage applied to OUT is above the minimum start-up voltage. When OTG_EN is HIGH, both ACOK and $\overline{\text{ACOK}}$ are de-asserted. During OTG mode, if IN rises above OVLO, then both switches will be turned OFF. For correct operation it is recommended that power is supplied to OUT prior to OTG operation and removed before OTG operation is discontinued.

ACOK/ $\overline{\text{ACOK}}$ Outputs

The $\overline{\text{ACOK}}$ output is an active-low open-drain flag reporting good operation of the device. A pull-up resistor should be connected from the $\overline{\text{ACOK}}$ pin to the system I/O rail.

The ACOK output is an active-high, switch, connecting a regulated 1.8V to the output pin. A pull-down resistor should be connected from the ACOK pin to GND.

For both outputs a fault is flagged in the case of an over-voltage, under-voltage or over-temperature fault occurring.

Thermal Protection

The KTS1686 features thermal shutdown to prevent the device from overheating. The internal FETs turn off when the junction temperature exceeds +150°C (typ). The device exits thermal shutdown after the junction temperature cools by 25°C (typ) hysteresis.

Applications Information

Input Capacitor

A 0.1 μ F ceramic bypass capacitor may be connected between IN and GND as close to the device as possible. If there is a significant capacitance, caused by the long lead length between the KTS1686 and the power source, this bypass capacitor prevents overshoot, due to the LC tank circuit and provides protection by clamping any overshoot.

Output Capacitor

The soft-start function provides a slow turn-on that allows the KTS1686 to charge large output capacitors without turning off due to an over-current condition. As a minimum it is recommended to bypass OUT with a 1 μ F ceramic capacitor.

ESD Test Conditions and Human Body Model ESD Protection

The KTS1686 is fully protected on all pins against electrostatic discharges up to ± 2 kV (HBM) encountered during handling and assembly. In addition the IN pin is further protected up to ± 15 kV ESD HBM, ± 15 kV Air-Gap Discharge, and ± 8 kV Contact Discharge as described in IEC61000-4-2.

Packaging Information

WLCSP-15, 1.567mm x 2.137mm

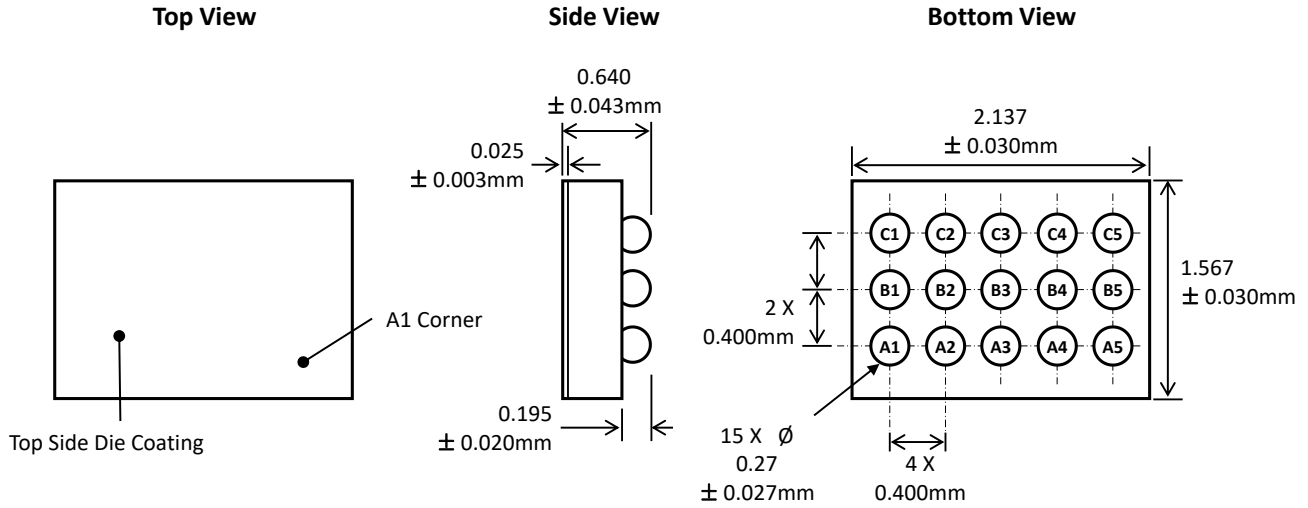

Kinetic Technologies cannot assume responsibility for use of any circuitry other than circuitry entirely embodied in a Kinetic Technologies product. No intellectual property or circuit patent licenses are implied. Kinetic Technologies reserves the right to change the circuitry and specifications without notice at any time.

X-ON Electronics

Largest Supplier of Electrical and Electronic Components

Click to view similar products for [Power Switch ICs - Power Distribution](#) *category:*

Click to view products by [Kinetic Technologies](#) *manufacturer:*

Other Similar products are found below :

[TCK111G,LF\(S\)](#) [FPF1018](#) [DS1222](#) [TCK2065G,LF](#) [SZNCP3712ASNT3G](#) [MIC2033-05BYMT-T5](#) [MIC2033-12AYMT-T5](#) [MIC2033-05BYM6-T5](#) [SLG5NT1437VTR](#) [SZNCP3712ASNT1G](#) [NCV330MUTBG](#) [DML1008LDS-7](#) [KTS1670EDA-TR](#) [KTS1640QGDV-TR](#) [KTS1641QGDV-TR](#) [NCV459MNWTBG](#) [FPF2260ATMX](#) [U6513A](#) [U6119S](#) [NCP45780IMN24RTWG](#) [MAX14919ATP+](#) [MC33882PEP](#) [TPS2021HDRQ1](#) [TPS2104DBVR](#) [MIC2098-1YMT-TR](#) [MIC94062YMT TR](#) [MP6231DN-LF](#) [MIC2075-2YM](#) [MIC2095-2YMT-TR](#) [MIC94068YML-TR](#) [SIP32461DB-T2-GE1](#) [NCP335FCT2G](#) [FPF2701MX](#) [TCK105G,LF\(S\)](#) [AP2151DSG-13](#) [MIC94094YC6-TR](#) [MIC94064YC6-TR](#) [MIC2505-1YM](#) [MIC94042YFL-TR](#) [MIC94041YFL-TR](#) [MIC2005-1.2YM6-TR](#) [TPS2032QDRQ1](#) [SIP32510DT-T1-GE3](#) [NCP333FCT2G](#) [NCP331SNT1G](#) [TPS2092DR](#) [TPS2063DR](#) [TPS2042P](#) [MIC2008YML-TR](#) [MIC2040-1YMM](#)