

### Low Resistance Load Switch with Current Limit Control and Over-Voltage Reverse Blocking Protection

#### Features

- Wide Input voltage range: 2.5V to 5.5V
- 28V Absolute Ratings at  $V_{OUT}$
- Adjustable Current Limit to 2.5A
- Integrated MOSFET with  $68m\Omega$  (Typ) at  $5V_{IN}$  and  $1A I_{OUT}$
- Output OVP 5.8V (Typ)
- Open-Drain over-current fault flag
- Integrated protection
  - ▶ Thermal Shutdown
  - ▶ Under-Voltage Lockout (UVLO)
  - ▶ Soft-start
  - ▶ OUT to IN Reverse Blocking
- Pb-free Package:
  - ▶ 9-Bump WLCSP 1.22mm x 1.22mm
- $-40^{\circ}C$  to  $+85^{\circ}C$  Temperature Range

#### Brief Description

The KTS1688 is a slew-rate controlled,  $68m\Omega$  (Typ), low resistance MOSFET switch intended to be inserted between a power source and a load to isolate and protect against abnormal voltage and current conditions. Featuring slew-rate turn on control, to prevent excessive input voltage or battery droop resulting from a large inrush current, the KTS1688 also features several additional protection functions, such as output over-voltage and input under-voltage protection, plus over-current (with Fault-flag) and over-temperature protection.

Operating from a wide input voltage range of 2.5V to 5.5V, the KTS1688 in the OFF state can block voltages on the OUT pin of up to 28V. The switch CTRL input is active high and includes a resistor pull-down.

The device is packaged in advanced, fully “green” compliant, 1.22mm x 1.22mm, Wafer-Level Chip-Scale Package (WLCSP).

#### Applications

- Smart Phones, and Tablets
- Mobile Internet Devices
- Peripherals
- Storage, DSLR and Portable Devices

#### Typical Application

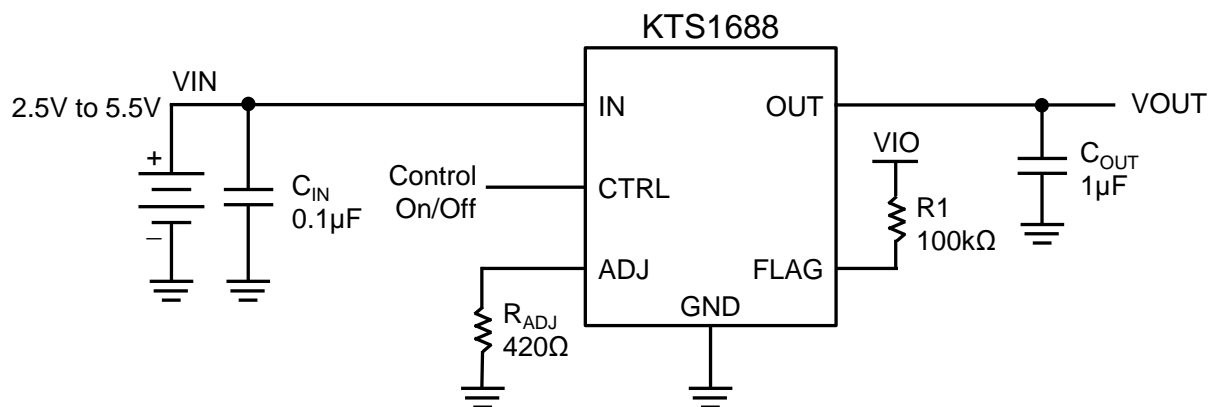

### Pin Descriptions

Pin #	Name	Function		
A3, B3	OUT	Switch Output		
A1, B1	IN	Supply Input: Input to the power switch		
A2	GND	Ground reference		
B2				
C3	CTRL	Logic Enable Control Input: Active HIGH – GPIO compatible	Logic HIGH	Enable Operation
			Logic LOW	Disable Operation
C1	FLAG	Flag Output: Active LOW, open-drain to indicate current limiting. . External pull-up resistor of greater than 10k is recommended		
C2	ADJ	Current Limit adjustment pin: An external resistor from ADJ to GND sets the current limit at the output.		

### WLCSP-9

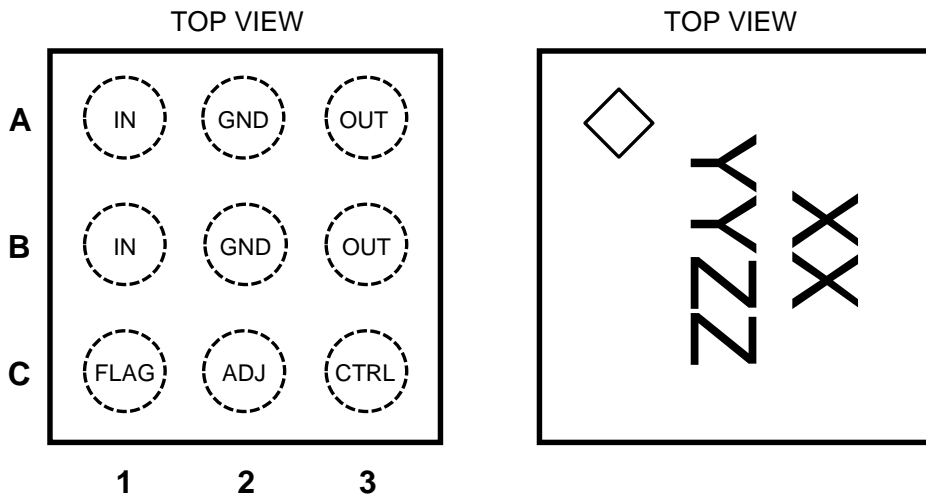

9-Bump 1.22 x 1.22 mm  
WLCSP Package

YYZZ (Date Code and Assembly Code)  
XX = Device Code (Top Mark)

### Absolute Maximum Ratings<sup>1</sup>

(T<sub>A</sub> = 25°C unless otherwise noted)

Symbol	Description	Value	Units
OUT	Output voltage	-0.3 to 28.0	V
IN	Input Voltage	-0.3 to 6.0	
CTRL, FLAG, ADJ	Control, Flag and Adjust pins	-0.3 to 6.0	
I <sub>SW</sub>	Maximum Continuous Switch Current <sup>2</sup>	2.8	A
t <sub>PD</sub>	Total Power Dissipation at T <sub>A</sub> = 25°C	1.0	W
T <sub>J</sub>	Operating Junction Temperature	-40 to +150	°C
T <sub>STG</sub>	Storage Junction Temperature	-65 to +150	°C

### Thermal Capabilities

Symbol	Description	Value	Units
Θ <sub>JA</sub>	Thermal Resistance – Junction to Ambient <sup>3</sup>	95	°C/W
P <sub>D</sub>	Maximum Power Dissipation at T <sub>A</sub> ≤ 25°C	1	W
ΔP <sub>D</sub> /ΔT	Derating Factor Above T <sub>A</sub> = 25°C	-10.5	mW/°C

### Recommended Operation Conditions<sup>4</sup>

Symbol	Description	Value	Units
V <sub>IN</sub>	Supply Voltage	2.5 to 5.5	V
T <sub>A</sub>	Ambient Operating Temperature	-40 to +85	°C

### Ordering Information

Part Number	Marking <sup>5</sup>	Operating Temperature	Package
KTS1688EUH-TR	JEYYZZ	-40°C to +85°C	WLCSP-9

1. Stress exceeding the absolute maximum rating may damage the device. The device may not function or be operable above the recommended operating conditions and stressing the parts to these levels is not recommended. In addition, extended exposure to stresses above the recommended operating conditions may effect device reliability. The absolute maximum ratings are stress ratings only.
2. Maximum Junction Temperature = 85°C
3. Junction to Ambient thermal resistance is highly dependent on PCB layout. Values are based on thermal properties of the device when soldered to an EV board.
4. The recommended Operating Conditions table defines the conditions for actual device operation. Recommended operating conditions are specified to ensure optimal performance to the datasheet specifications. Kinetic does not recommend exceeding them or designing to Absolute Maximum Rating.
5. "YYZZ" is the date code and assembly code.

### Electrical Characteristics<sup>6</sup>

Unless otherwise noted,  $V_{IN} = 2.5V$  to  $5.5V$ ,  $T_A = -40^{\circ}C$  to  $+85^{\circ}C$ , typical values are at  $V_{IN} = 5V$  and  $T_A = 25^{\circ}C$ .

Symbol	Description	Conditions	Min	Typ	Max	Units
<b>Basic Operation</b>						
$V_{IN}$	Input Voltage		2.5		5.5	V
$V_{UVLO}$	Under-Voltage Lockout	$V_{IN}$ Increasing		2.3		V
$V_{UVLO\_HYS}$	UVLO Hysteresis			0.3		V
$I_{SD(OFF)}$	Shutdown Current	$V_{IN} = 5.5V$ , CTRL = GND		1.0	4.0	$\mu A$
$I_Q$	Quiescent Current	$I_{OUT} = 0mA$		120	160	$\mu A$
$R_{ON}$	ON Resistance	$V_{IN} = 5.0V$ , $I_{OUT} = 1A$		68	95	m $\Omega$
		$V_{IN} = 3.7V$ , $I_{OUT} = 1A$		75	105	
$V_{IH}$	CTRL Input Logic HIGH Voltage	$V_{IN} = 2.5V$ to $5.5V$	1.25			V
$V_{IL}$	CTRL Input Logic LOW Voltage	$V_{IN} = 2.5V$ to $5.5V$			0.55	V
$V_{OL\_FLAG}$	FLAG Output Logic LOW Voltage	$V_{IN} = 5V$ , $I_{SINK} = 1mA$		0.1	0.2	V
		$V_{IN} = 2.5V$ , $I_{SINK} = 1mA$		0.15	0.30	
$I_{FLAG\_LK}$	FLAG Output High Leakage Current	$V_{IN} = 5V$ , Switch On			1	$\mu A$
$R_{CTRL}$	Pull-Down Resistance at CTRL Pin			4		M $\Omega$
<b>Over-Voltage Protection</b>						
$V_{OV\_TRIP}$	Output OVP Lockout	$V_{OUT}$ Rising Threshold	5.5	5.8	6.0	V
		$V_{OUT}$ Falling Threshold		5.7		
$OUT_{HYS}$	Output OVP Hysteresis			0.1		V
$T_{OVP}$	OVP Response Time	$I_{OUT} = 0.5A$ , $C_L = 1\mu F$ , $T_A = 25^{\circ}C$ , $V_{OUT}$ from 5.5V to 6.0V		0.2		$\mu s$
<b>Over-Current Protection</b>						
$I_{LIM}$	Current Limit	$V_{IN} = 5V$ , $R_{ADJ} = 420\Omega$ , $V_{OUT} = 1.68V$ to $5V^7$	2.2	2.5	2.8	A
$t_{OCP}$	Over-Current Response Time	Moderate Over-Current Condition, $I_{OUT} \geq I_{LIM}$ , $V_{OUT} \leq V_{IN}$		7		$\mu s$
$t_{OC\_FLAG}$	Over-Current Flag Response Time	When Over-Current Occurs to Flag Pulling LOW		9		ms
TSD	Thermal Shutdown			150		$^{\circ}C$
$T_{HYST}$	Thermal Hysteresis			20		$^{\circ}C$
<b>Dynamic Characteristics</b>						
$t_{DON}$	Turn-On Delay <sup>8</sup>	$V_{IN} = 5V$ , $R_L = 100\Omega$ , $C_L = 1\mu F$ , $T_A = 25^{\circ}C$ , $R_{ADJ} = 2040\Omega$		0.6		ms
$t_R$	$V_{OUT}$ Rise Time <sup>8</sup>			0.6		ms
$t_{DOFF}$	Turn-Off Delay			0.1		ms
$t_F$	$V_{OUT}$ Fall Time			0.22		ms

6. KTS1688 is guaranteed to meet performance specifications over the  $-40^{\circ}C$  to  $+85^{\circ}C$  operating temperature range by design, characterization and correlation with statistical process controls.

7. Based on characterization with a 1% tolerance resistor

8. Timing defined in Figure 1

Timing Diagram

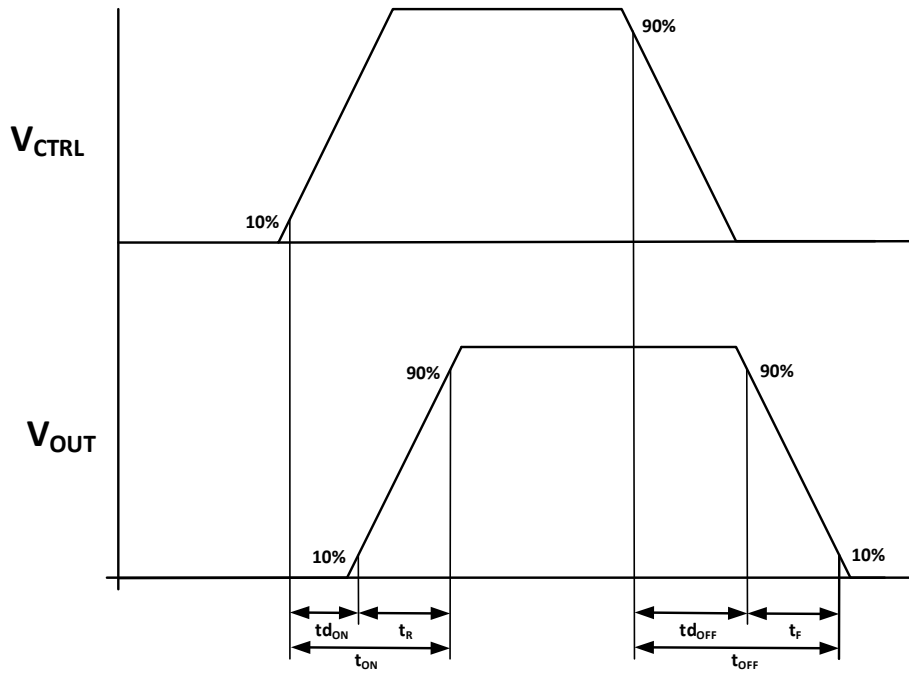
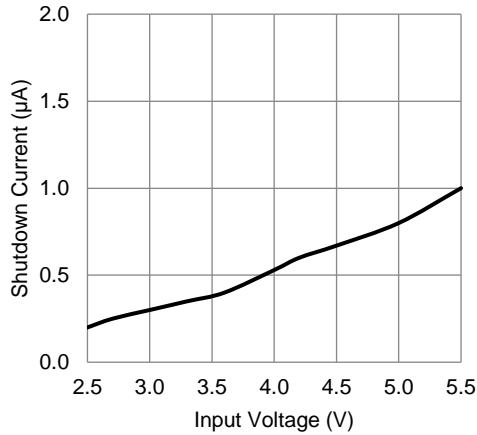

Figure 1. Timing Diagram

### Typical Characteristics

$V_{IN} = 5V$ ,  $C_{IN} = 0.1\mu F$ ,  $C_{OUT} = 1\mu F$ ,  $R_{ADJ} = 420\Omega$ ,  $CTRL = V_{IN}$ , Temp = 25°C unless otherwise specified.

Shutdown Current vs.  $V_{IN}$  (CTRL = GND)



Quiescent Current vs.  $V_{IN}$  (No load)

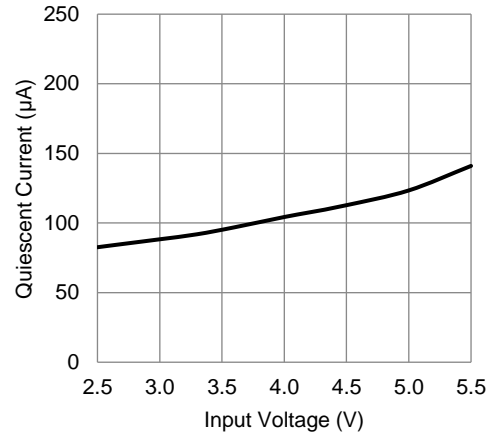

CTRL Enable Threshold vs.  $V_{IN}$

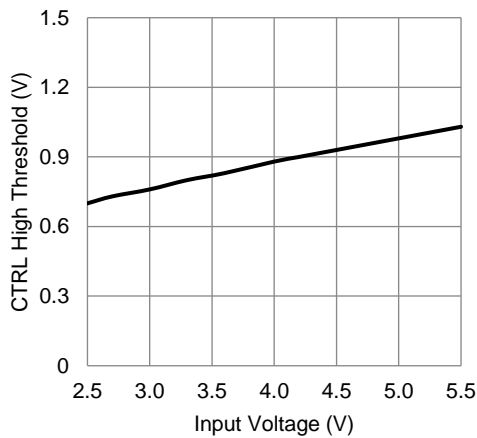

### Typical Characteristics (continued)

$V_{IN} = 5V$ ,  $C_{IN} = 0.1\mu F$ ,  $C_{OUT} = 1\mu F$ ,  $R_{ADJ} = 420\Omega$ ,  $CTRL = V_{IN}$ , Temp = 25°C unless otherwise specified.

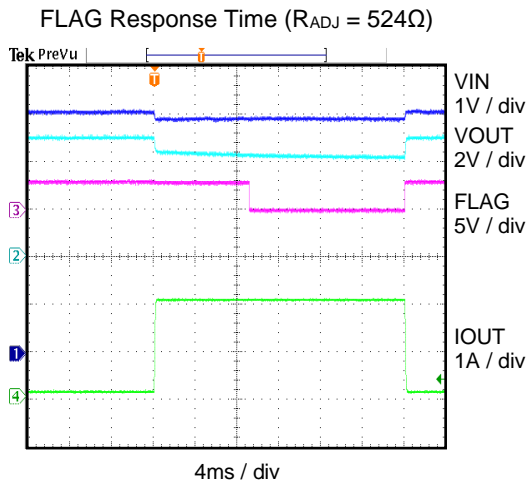
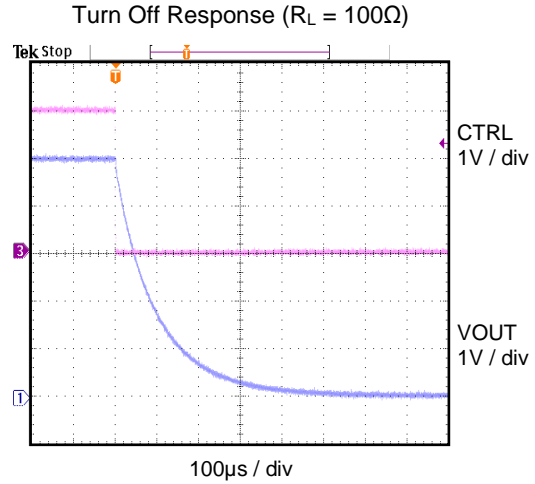
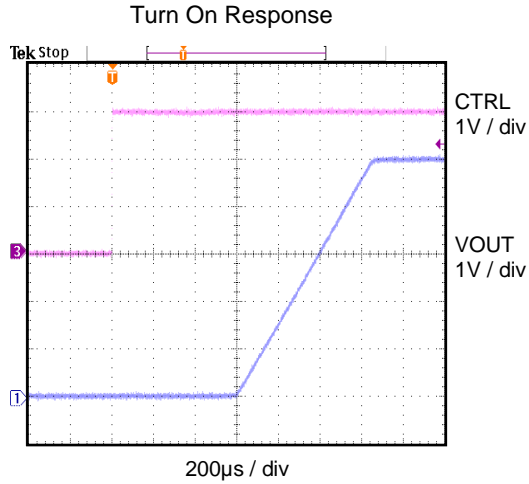

### Functional Block Diagram

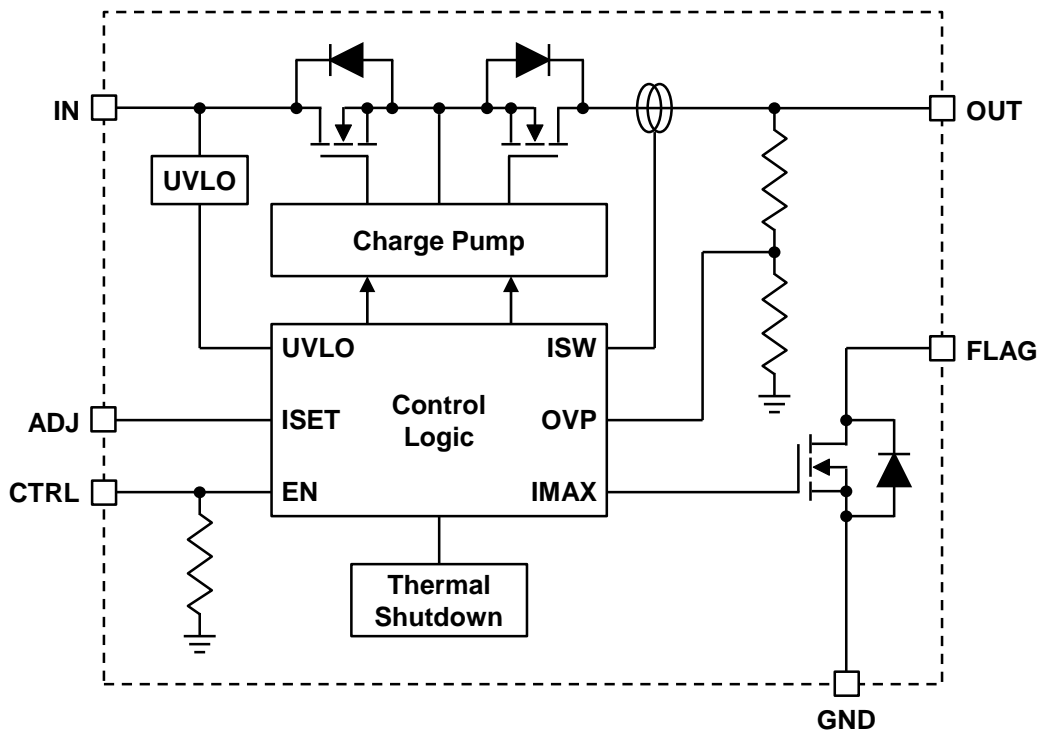

### Functional Description

The KTS1688 is a slew-rate controlled, 68mΩ, low resistance MOSFET switch intended to be inserted between a power source and a load to isolate and protect against abnormal voltage and current conditions. Featuring slew-rate turn on control, to prevent excessive voltage droop resulting from large inrush current, the KTS1688 also features several additional protection functions, such as output over-voltage and input under-voltage protection, plus over-current and over-temperature protection.

Operating from a wide input voltage range of 2.5V to 5.5V, the KTS1688 in the OFF state can block voltages on the OUT pin of up to 28V.

#### Under-Voltage Lockout (UVLO)

When CTRL is taken high, the UVLO function will keep the switch in the OFF state until the input voltage rises above the UVLO threshold. If the input voltage falls below this threshold the switch will return to the OFF state.

#### Fault Reporting (FLAG)

In an over-current condition the FLAG pin will be asserted LOW. A pull-up resistor should be connected from FLAG to the system I/O rail.



### Current Limiting

The current limit is set by an external resistor connected between the ADJ and GND pins. When the switch current reaches the maximum value set, the switch will act as constant current source until the power dissipation causes thermal shutdown. When the chip temperature cools, the device will recover and turn back on. The current limit resistor setting is shown below in Figure 2. A resistor with a tolerance of 1% or less is recommended.

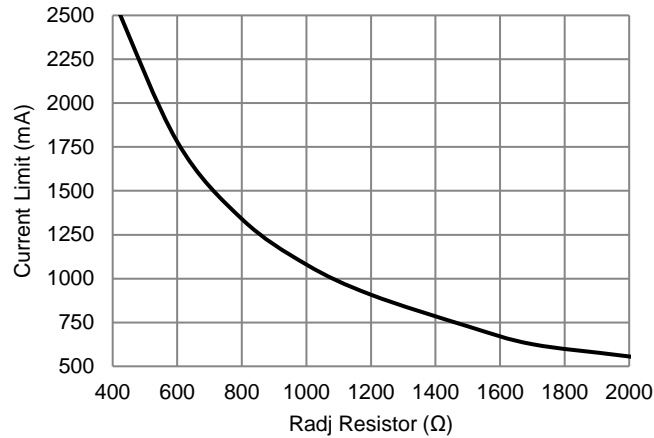

**Figure 2. Current Limit Resistor Settings<sup>9</sup>**

### Thermal Protection

The KTS1688 features thermal shutdown to prevent the device from overheating. The internal FETs turn off when the junction temperature exceeds +150°C (typ). The device exits thermal shutdown after the junction temperature cools by 20°C (typ) hysteresis.

<sup>9</sup> Recommend 1% tolerance resistors.

## Applications

### Input Capacitor

For most applications, connect a 1nF ceramic capacitor as close as possible to the device from IN to GND to minimize the effect of parasitic trace inductance.

### OUT Output Capacitor

The internal soft-start function allows the KTS1688 to charge an output capacitor up to 100 $\mu$ F without turning off due to overcurrent. As a minimum it is recommended to bypass OUT with a 1 $\mu$ F ceramic capacitor.

### Layout Recommendation

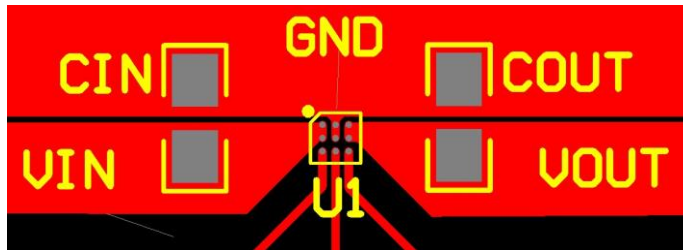
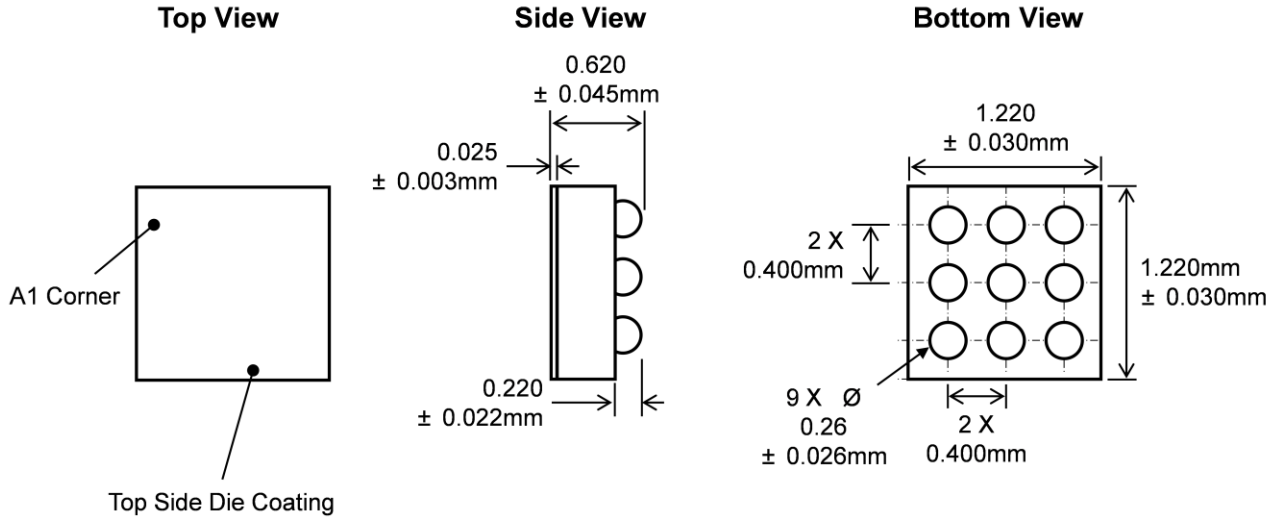

Figure 3. Recommended PCB Layout for WLCSP-9 Package

### Package Drawing

WLCSP-9, 1.22mm x 1.22mm x 0.62mm



### Recommended Footprint

(NSMD Pad Type)

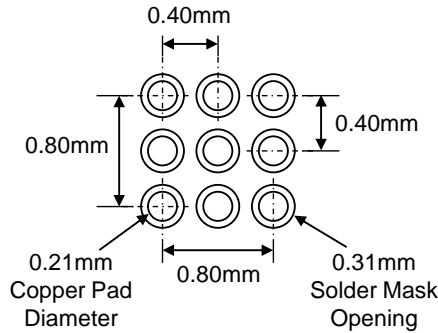

\* Dimensions are in millimeters.

Kinetic Technologies cannot assume responsibility for use of any circuitry other than circuitry entirely embodied in a Kinetic Technologies product. No intellectual property or circuit patent licenses are implied. Kinetic Technologies reserves the right to change the circuitry and specifications without notice at any time.

## X-ON Electronics

Largest Supplier of Electrical and Electronic Components

*Click to view similar products for* [Power Switch ICs - Power Distribution](#) *category:*

*Click to view products by* [Kinetic Technologies](#) *manufacturer:*

Other Similar products are found below :

[AP22652AW6-7](#) [MAPDCC0001](#) [L9349TR-LF](#) [MAPDCC0005](#) [NCP45520IMNTWG-L](#) [VND5050K-E](#) [MP6205DD-LF-P](#)  
[MC15XS3400DHFKR2](#) [FPF1015](#) [FPF1018](#) [DS1222](#) [TCK2065G,LF](#) [SZNCP3712ASNT3G](#) [L9781TR](#) [NCP45520IMNTWG-H](#)  
[MC17XS6500BEK](#) [SP2526A-1EN-L/TR](#) [SP2526A-2EN-L/TR](#) [MAX4999ETJ+T](#) [MC22XS4200BEK](#) [MAX14575BETA+T](#) [VN1160C-1-E](#)  
[VN750PEP-E](#) [TLE7244SL](#) [BTS50060-1EGA](#) [MAX1693HEUB+T](#) [MC07XSG517EK](#) [TLE7237SL](#) [MIC2033-05BYMT-T5](#) [MIC2033-](#)  
[12AYMT-T5](#) [MIC2033-05BYM6-T5](#) [MP6513LGJ-P](#) [NCP3902FCCTBG](#) [AP22811BW5-7](#) [SLG5NT1437VTR](#) [SZNCP3712ASNT1G](#)  
[NCV330MUTBG](#) [DML1008LDS-7](#) [MAX4987AEETA+T](#) [KTS1670EDA-TR](#) [MAX1694EUB+T](#) [KTS1640QGDV-TR](#) [KTS1641QGDV-TR](#)  
[IPS160HTR](#) [BTS500251TADATMA2](#) [NCV451AMNWTBG](#) [MC07XS6517BEKR2](#) [SIP43101DQ-T1-E3](#) [DML10M8LDS-13](#)  
[MAX1922ESA+C71073](#)