

深圳市金航标电子有限公司  
SHENZHEN KINGHELM ELECTRON CO.,LTD.

www.kinghelm.com.cn  
0755-28190160

# 产品规格书

## Product Specification

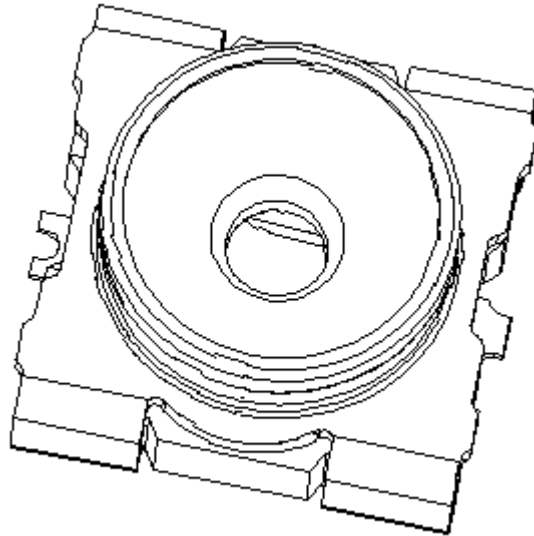

P/N:

**KH-252515-G2.2**

Title :

**Mini RF II Switch Connector**

Rev.	ECN	Release and Revision Description	<u>Prepared By/Date:</u>	<u>Approved By/Date:</u>
<b>X1</b>	KH-252515-G2.2	NEW RELEASE	Qian/16.09-25	Martin /16.09-25

# Product Specification

深圳市金航标电子有限公司  
SHENZHEN KINGHELM ELECTRON CO.,LTD.

P/N:

KH-252515-G2.2

Rev.:

X1

Page:

2/15

## Content

### 目录

1. Scope/范围: .....	3
2. Product Application/产品应用: .....	3
3. Technology Parameters/技术参数.....	3
4. Ratings/额定性能要求 .....	3
5. Electrical Performance/电气性能.....	4
6. Mechanical Performance/机械性能 .....	5
7. Environmental Performance/环境性能 .....	7
8. Profile Dimensions and material specifications /外形尺寸及材料规格 .....	9
9. Recommended PCB Layout And Metal Mask 推荐的 PCB 安装焊盘及钢网规格 .....	10
10. Recommended Reflow Soldering Condition/SMT 推荐的回流焊接温度曲线图.....	10
11. Test Sequence and Sample Quantity/测试顺序及样品数量.....	11
12. Recommended Mating test Probe 推荐的测试探针 .....	12
13. Packaging 包装.....	13
14. Usage Precaution 使用禁忌或注意事项 .....	14

# Product Specification

深圳市金航标电子有限公司  
SHENZHEN KINGHELM ELECTRON CO.,LTD.

P/N:

KH-252515-G2.2

Rev.:

X1

Page:

3/15

## 1. Scope/范围:

This Product Specification covers the requirement of Mini RF II Switch Connector on product performance, test methods and quality assurance provisions.

本规格书内容涵盖 Mini RF 第 II 代开关型同轴连接器产品的要求, 包括性能指标、测试方法及质量保证方面等。

## 2. Product Application/产品应用:

The SMT type coaxial connector with switch is designed for Characteristic Measurement in the Mobile phones, W-LAN M, Microwave equipments, etc, application. Please let us know before using any of the products in the application not described above.

该SMT型同轴带开关连接器产品用于移动电话、W-LAN、其它无线和测量设备等领域电路的特性测量, 如果用于本文中未提及的领域请在使用前告知。

## 3. Technology Parameters/技术参数

3.1 Frequency Range(频率范围)	DC~11GHz
3.2 Nominal Characteristic Impedance (特性阻抗)	50 +/-5 Ohm
3.3 Power Rating (额定功率)	2W
3.4 V.S.W.R(电压驻波比)	1.2 Max.(DC~3GHz); 1.3 Max.(3~6GHz); 1.5 Max.(6~11GHz);
3.5 Insertion Loss(插入损耗)-NC State	-0.1dB Max.(DC~3GHz); -0.2dB Max.(3~6GHz); -0.6dB Max.(6~11GHz);
3.6 Isolation(隔离度)-NO State	-20dB Min.(DC~3GHz); -15dB Min.(3~6GHz); -10dB Min.(6~11GHz);
3.7 Operating Temperature Range (工作温度范围)	-40°C ~ +85°C
3.8 Operating Humidity (工作湿度)	95% R.H.MAX

## 4. Ratings/额定性能要求

4.1 Voltage Rating (额定电压)	250V AC (R.M.S)
4.2 Initial Insulation Resistance (绝缘电阻)	500 M Ohm
4.3 Withstand Voltage (耐电压)	300V AC 1 Min.
4.4 Contact Resistance (接触电阻)	
4.4.1 Inner Contact (内导体) (扣除导体电阻) (Without conductor resistance)	120m ohm Max.
4.4.2 Outer Contact (外导体)	20 m ohm Max.
4.5 Durability(耐久性)	500 Cycles.

# Product Specification

深圳市金航标电子有限公司  
SHENZHEN KINGHELM ELECTRON CO.,LTD.

P/N:

KH-252515-G2.2

Rev.:

X1

Page:

4/15

## 5. Electrical Performance/电气性能

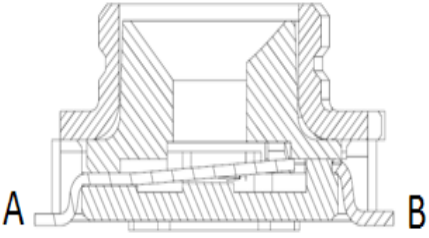
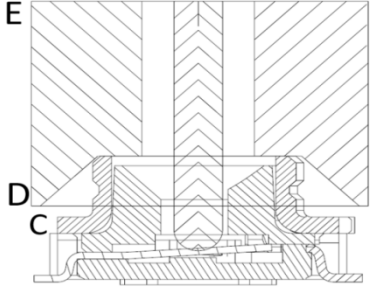
Item 项目	Description 项目描述	Test Condition 测试条件	Requirement 规格要求
5.1	Contact Resistance 接触电阻	(EIA 364-23C) Testing by the voltage dropping method with the low level current. 按照 EIA364-23C 要求, 采用低电平压降方式测量电阻值。 Open circuit voltage 开路电压: 20mV MAX Circuit current 电流: 100mA MAX *Note: Test Methods are as following Figure1 and Figure 2, Body Resistance is eliminated here. 备注: 测试方法参照图 1 和图 2, 此处的接触电阻测试不包括体电阻。	Inner contact 中心导体 : Initial 初始 120mΩ Max.* : After 测试后 150mΩ Max.* Ground contact 外导体 : Initial 初始 20mΩ Max.* : After 测试后 50mΩ Max.*
		Inner contact /中心导体: $R_{AB}$	Ground contact/外导体: $R_{CE} - R_{DE}$
		 <p style="text-align: center;"><b>Figure 1</b></p>	 <p style="text-align: center;"><b>Figure 2</b></p>
5.2	Insulation Resistance 绝缘电阻	(EIA 364-21E) Testing by applying the specified voltage (DC 200 V) between the inner and ground contacts for one minute. 在内外导体之间施加 200V DC 的电压, 测试时间 1 分钟。	Initial 初始: 500 MΩ MIN After 试验后: 100 MΩ MIN
5.3	Dielectric withstanding voltage 耐电压	(EIA364-20F) Testing by applying the specified voltage( AC 300 V ) between the inner and ground contacts for one minute. 在内外导体之间施加 300V AC 的电压, 测试持续 1 分钟。	No evidence of breakdown 无瞬断、熔闪、击穿
5.4	V.S.W.R. (NC) 电压驻波比	Measurement system is as following figure 3 and tested by network analyzer. Frequency: DC~11GHz 如图 3 所示,通过网络分析仪测试; 频率范围为 DC~11GHz;	1.2 Max. (DC~3GHz); 1.3 Max. (3~6GHz); 1.5 Max. (6~11GHz);

深圳市金航标电子有限公司 SHENZHEN KINGHELM ELECTRON CO.,LTD.	<b>Product Specification</b>		
	P/N:	Rev.:	Page:
	KH-252515-G2.2	X1	5/15

5.5	<b>Insertion Loss (NC)</b> 插入损耗	Measurement system is as following figure 3 and tested by network analyzer. Frequency: DC~11GHz 如图 3 所示,通过网络分析仪测试; 频率范围为 DC~11GHz; Note: the loss of the other conductive part than the receptacle is not included. 注: 除产品外的所有其它导体引起的损耗被消除。	-0.1dBMax. (DC~3GHz); -0.2dBMax.(3~6GHz); -0.6dBMax.(6~11GHz);
5.6	<b>Isolation</b> 隔离度	Measurement system is as following figure 4 and tested by network analyzer. Frequency: DC~11GHz 如图 4 所示,通过网络分析仪测试; 频率范围为 DC~11GHz; Note: the manual testing probe should be inserted to the mating portion of the receptacle completely during the testing. 注: 此项测试中, 需要使用手动测试公头, 并保证完全插配到母座上。	-20dBMin. (DC~3GHz); -15dBMin. (3~6GHz); -10dBMin. (6~11GHz);

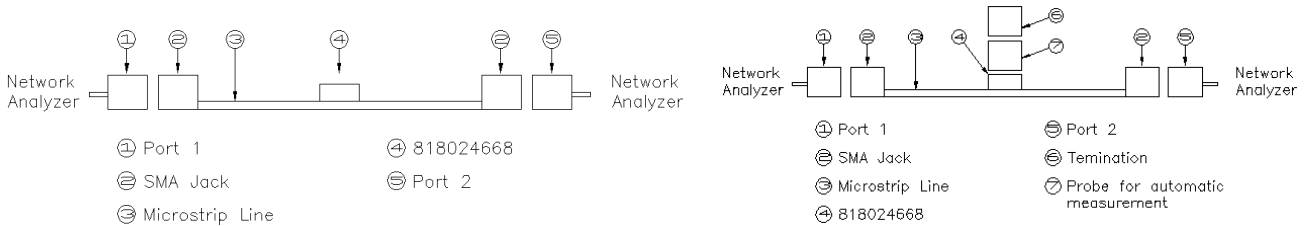
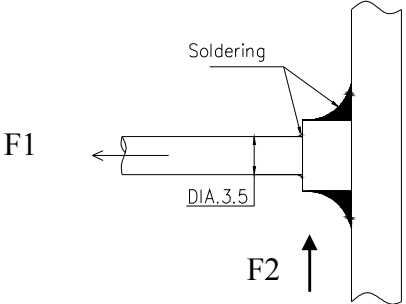

**Figure 3**

**Figure 4**

**6. Mechanical Performance/机械性能**

Item 项目	Description 项目描述	Test Condition 测试条件	Requirement 规格要求
6.1	<b>Engage and Disengage Force</b> 插拔力	EIA -364-13E Method A Measuring the required force for complete mated to the mated connector at 25±3mm/minutes. Measuring the required force for complete disengagement from the mated connector at 25±3mm/minutes. 测试完全插配到位时的插入力, 并测试完全分离时的拔出力; 插拔速率控制: 25±3 毫米/每分钟。	1.Mating Force (插入力): 30N(3Kgf) Max  2.Unmating Force (拔出力): 5~40N (0.5~4Kgf)

深圳市金航标电子有限公司 SHENZHEN KINGHELM ELECTRON CO.,LTD.		Product Specification		
		P/N: KH-252515-G2.2	Rev.: X1	Page: 6/15
6.2	Durability 耐久性	(EIA364-09D) Engage and disengage the receptacle connector which is soldered to the test board and its mating plug cable for 100 cycles at the speed of 25±3mm/minutes along the mating direction by the push-push machine. 将母座焊接在测试板上，然后，通过插拔力测试仪沿配合方向以每分钟 25±3 毫米的速度插拔公母头 500 个循环进行测试。	Appearance: No abnormality 外观：无损伤  Contact Resistance: Shall meet 5.1 接触电阻： 满足节 5.1 要求	
6.3	Adhered of Electrode Terminal 焊点保持力	Soldering test sample with test PCB . Measurement conditions are as followings according to figure 5: 将产品已正常焊接工艺焊在 PCB 上,按图 6 方式在下述条件下测量: 1. Pull Force(拉力):F1=50N , Time(间):5+/-1s. 2. Push Force(推力):F2=30N , Time(间):5+/-1s.	No excoriation of electrode terminal 焊接端子无明显脱落	
			Figure 5	
6.4	Vibration 机械振动	EIA -364-28F Condition II Apply the following vibration conditions to the mating connector. During the testing,run 100mA DC to check electrical discontinuity. Frequency:10Hz → 100Hz → 10Hz/approx 20minutes. Half amplitude,Peak value of acceleration: 3mm or 60m/s <sup>2</sup> (6G). Directions,cycle:3 mutually perpendicular direction,3 cycles for each direction. 将公母头配合，并施加如下条件测试.在测试期间,施加 100mA DC 电压,并检验电不连续性.频率： 10Hz→100Hz→10Hz/20minutes. 半振幅、加速度： 3mm、60 m/s <sup>2</sup> (6G) 方向和循环次数：每个互相垂直方向上进行 3 次测量。	Appearance: No abnormality 外观：无损伤;  Contact Res.: Shall meet 5.1 接触电阻： 满足节 5.1 的要求;  No discontinuities of 1 μ s or longer. 电不连续性不超过 1 μ s。	

# Product Specification

深圳市金航标电子有限公司  
SHENZHEN KINGHELM ELECTRON CO.,LTD.

P/N:

KH-252515-G2.2

Rev.:

X1

Page:

7/15

6.5	Shock 机械冲击	<p>EIA 364-27C Condition A The object of this test procedure is to detail a standard method to assess the ability of a connector to withstand specified severity of mechanical shock. Test Current: 100mA. Peak value of acceleration: 750m/s<sup>2</sup> (75G) Duration: 6ms Wave form : half sinusoidal Directions, cycle : 6 mutually perpendicular directions, 3 cycles about each direction</p> <p>此测试程序的目的是要作一详细标准以评估连接器能承受特定严格机械冲击的能力。 振幅峰值, : 750m/s<sup>2</sup> (75G) 持续时间: 6 毫秒 波型: 半正弦波, 方向和循环次数: 每 6 个相互垂直方向上各进次 3 次. 通电 100mA 测试电不连续性.</p>	<p>Appearance: No abnormality 外观: 无损伤;</p> <p>Contact Res.: Shall meet 5.1 接触电阻: 满足节 5.1 的要求;</p> <p>No discontinuities of 1 μs or longer. 电不连续性不超过 1 μs.</p>
-----	---------------	---	---

## 7. Environmental Performance/环境性能

Item 项目	Description 项目描述	Test Condition 测试条件	Requirement 规格要求
7.1	Humidity 恒温恒湿试验	<p>(EIA-364-31F Condition A) Test is done without mating adaptor ; Temperature : 65°C. Humidity : 95%R.H. Duration: 96 hours(50hours*). Note: The condition is under the “*”value when test is done with adaptor. 在未用转接器插合状态下, 根据 EIA-364-31F 条件 A 测试。 温度: 65°C; 湿度: 95%R.H; 持续时间: 96 小时(50 小时*); 备注: 1) 在有转接器插合状态下测试时间为 “*” 值.</p>	<p>Appearance: No abnormality 外观: 无损伤;</p> <p>Contact Resistance: shall meet 5.1 接触电阻: 满足 5.1;</p> <p>Insulation Resistance: shall meet 5.2 绝缘电阻: 满足 5.2; Dielectric withstanding voltage shall meet 5.3 耐电压: 满足 5.3</p>

深圳市金航标电子有限公司 SHENZHEN KINGHELM ELECTRON CO.,LTD.		Product Specification		
		P/N: KH-252515-G2.2	Rev.: X1	Page: 8/15
7.2	Thermal Shock 冷热冲击	<p>(EIA-364-32G Method A, Test condition I, Test duration A) Apply the following environment to the mating connector as following: -50°C(30min)~25°C(5max) ~ 90°C(30min) ~ 25°C(5max) Transition time: : 5min. MAX Cycles: 50 Cycles</p> <p>根据 (EIA-364-32G 方法 A, 试验条件 I, 试验持续时间 A) 对配对连接器施加以下环境, 如下测试: 循环: -50°C(30min)~25°C(5max)~90°C(30min) ~ 25°C(5max) 转换时间: 5 min Max. 循环次数: 50 次数</p>	<p>Appearance: No abnormality 外观: 无损伤; Contact Resistance: shall meet 5.1. 接触电阻: 满足节 5.1 中的要求;</p> <p>Insulation Resistance: shall meet 5.2 绝缘电阻: 满足节 5.2 中的要求;</p> <p>Dielectric withstanding voltageshall meet 5.3. 耐电压: 满足节 5.3 中的要求。</p>	
7.3	Solderability 可焊性	<p>EIA-364-52B (已被 J-STD-002E 代替) Apply the following environment to the mating connector Temperature : 245±5°C Duration : 5 +0/-0.5 second Test sample should be observed by the magnification of 10times after the test. 按下列条件对已配合的连接器进行测试. 温度: 245+/-5°C 持续时间:5 +0/-0.5 秒钟. 观测: 10 倍放大镜</p>	<p>At least 95% covered by a continuous new solder coating. 吃锡面积大于 95%以上。</p>	
7.4	Resistance to soldering heat 耐焊接热	<p>According to the following conditions to test connector. 1. Infrared reflow soldering, the peak temperature of 260 degrees Celsius, reference temperature curve, and the requirements of the SMT2 time; 2. electric soldering iron, requires 300 degrees 5 seconds, 350 degrees below 3 seconds.</p> <p>按下列条件进行测试: 1.红外线回流焊接, 峰值温度260度以下, 可参考温度曲线图, 且要求SMT2次; 2.电烙铁焊接, 要求300度5秒, 350度3秒以下。</p>	<p>Appearance: No abnormality. 外观无明显损伤;</p> <p>Coplanarity of the solder tail should be not beyond 0.10mm 焊脚平面度不超 0.10mm。</p>	



# Product Specification

深圳市金航标电子有限公司  
SHENZHEN KINGHELM ELECTRON CO.,LTD.

P/N:

KH-252515-G2.2

Rev.:

X1

Page:

9/15

7.5

Salt Spray  
盐雾测试

(EIA-364-26C)

Apply the following environment to the mating connector

Temperature :  $35 \pm 2^\circ\text{C}$

Relative Humidity : 90~98%R.H

Salt water density:  $5 \pm 1\%$

Duration : 48 hours for contact area

根据 EIA364-26C 试验要求,对已配合的连接器施加下列条件测试:

温度:  $35 \pm 2^\circ\text{C}$ ;

相对湿度: 90~98%R.H;

盐水浓度:  $5 \pm 1\%$ ;

持续时间: 48 hours; (端子接触区)

Appearance:  
No abnormality  
外观: 无损伤;

Contact Resistance:  
Shall meet 5.1  
接触电阻:  
满足节 5.1 中的要求

## 8. Profile Dimensions and material specifications /外形尺寸及材料规格

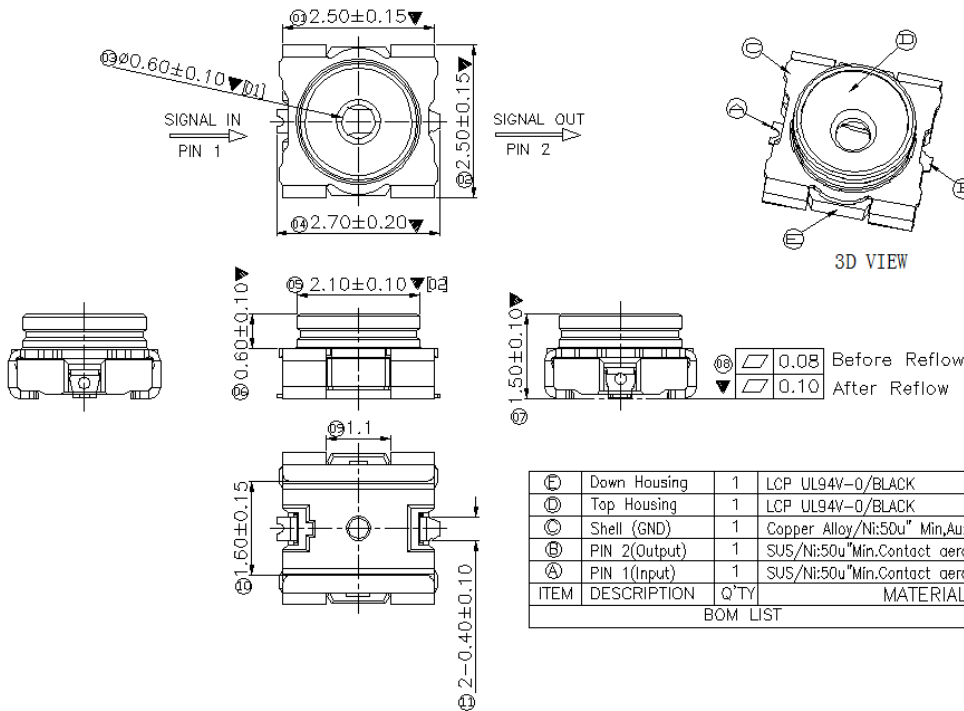

ITEM	DESCRIPTION	Q'TY	MATERIAL/FINISH
①	Down Housing	1	LCP UL94V-0/BLACK
②	Top Housing	1	LCP UL94V-0/BLACK
③	Shell (GND)	1	Copper Alloy/Ni:50u" Min,Au:1u" Min;
④	PIN 2(Output)	1	SUS/Ni:50u"Min.Contact aera Au:5u"Min,Solder aera Au:1u" Min
⑤	PIN 1(Input)	1	SUS/Ni:50u"Min.Contact aera Au:5u"Min,Solder aera Au:1u" Min
			BOM LIST

# Product Specification

深圳市金航标电子有限公司  
SHENZHEN KINGHELM ELECTRON CO.,LTD.

P/N:

KH-252515-G2.2

Rev.:

X1

Page:

10/15

## 9. Recommended PCB Layout And Metal Mask 推荐的 PCB 安装焊盘及钢网规格

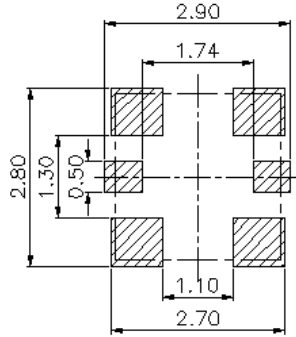

Recomend PCB Layout  
General Tolerance:  $\pm 0.05$

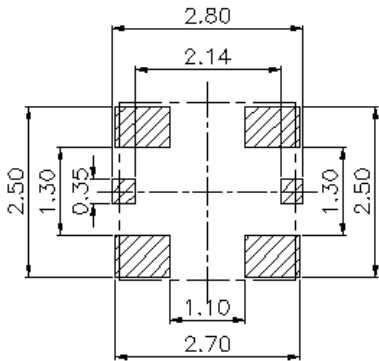

RECOMMEND METAL MASK  
(Mask thickness 0.12mm)

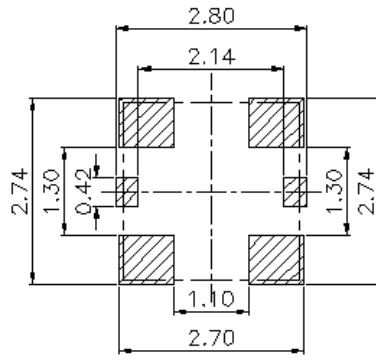

RECOMMEND METAL MASK  
(Mask thickness 0.10mm)

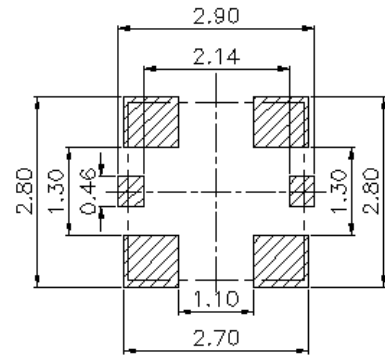

RECOMMEND METAL MASK  
(Mask thickness 0.08mm)

## 10. Recommended Reflow Soldering Condition/SMT 推荐的回流焊接温度曲线图

11.1 Recommended Temp.&Time of Reflow Soldering  
建议回流焊温度与时间条件

11.2 Reflow Soldering Standard Condition  
回流焊极限温度与时间条件

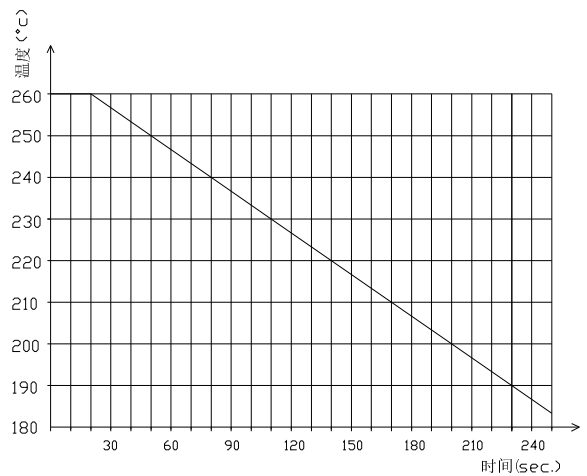
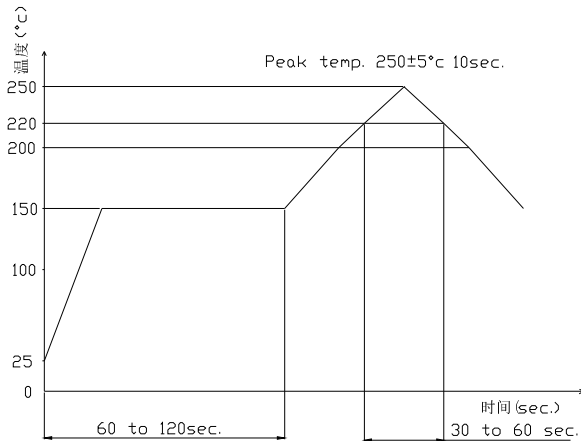



**12. Recommended Mating test Probe 推荐的测试探针**

**Type A:**

**818017735:**

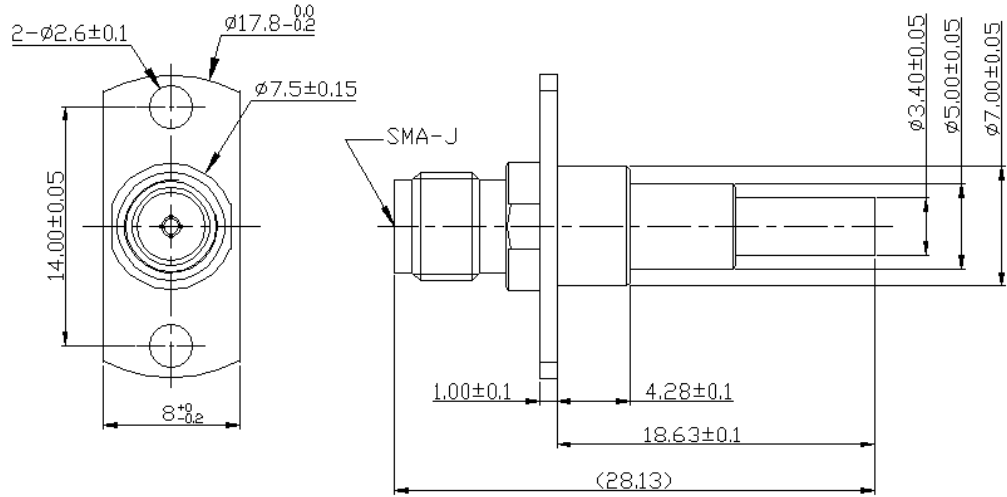

**Type B:**

**818017738:**

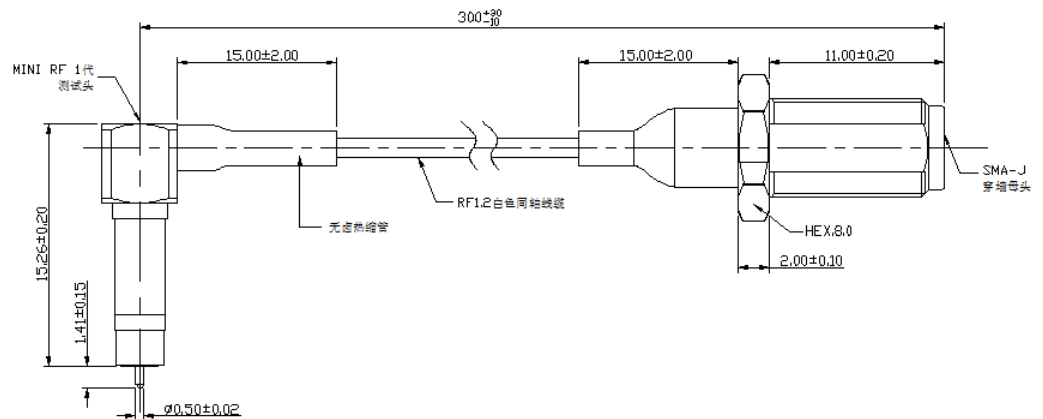

**Type C:**

**818022151:**

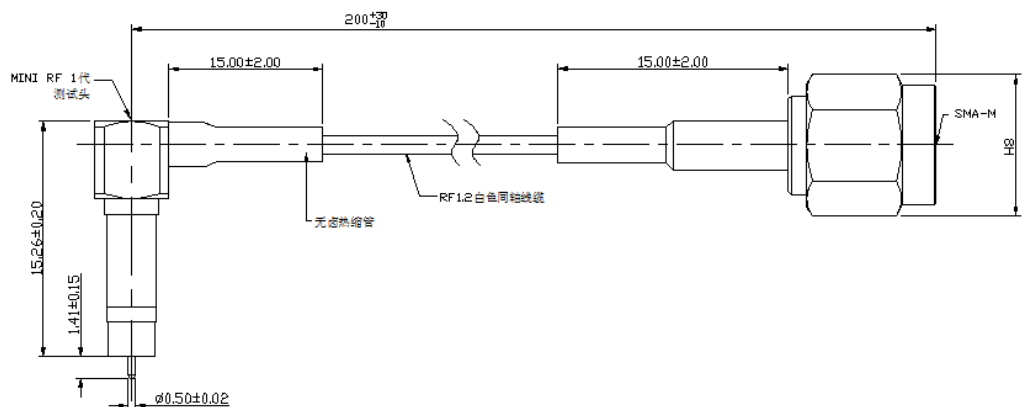

# Product Specification

深圳市金航标电子有限公司  
SHENZHEN KINGHELM ELECTRON CO.,LTD.

P/N:

KH-252515-G2.2

Rev.:

X1

Page:

13/15

## 13. Packaging 包装

13.1 The pull force of the tape: Pull the tape at the speed of 300mm/min, the pull force is 1.3N Max..

上带的剥离力度：300mm/min 的速度进行剥离，最大剥离力为 1.3N.

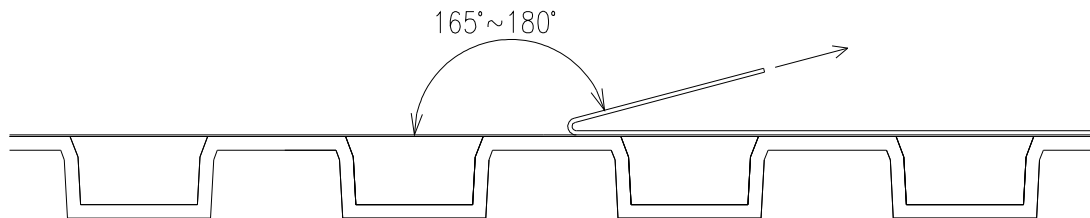

13.2 Packaging type: Tape&Reel, 1000Pcs/R (Φ 178mm) .

包装方式：载带包装， 1000Pcs /卷 (Φ 178mm) .

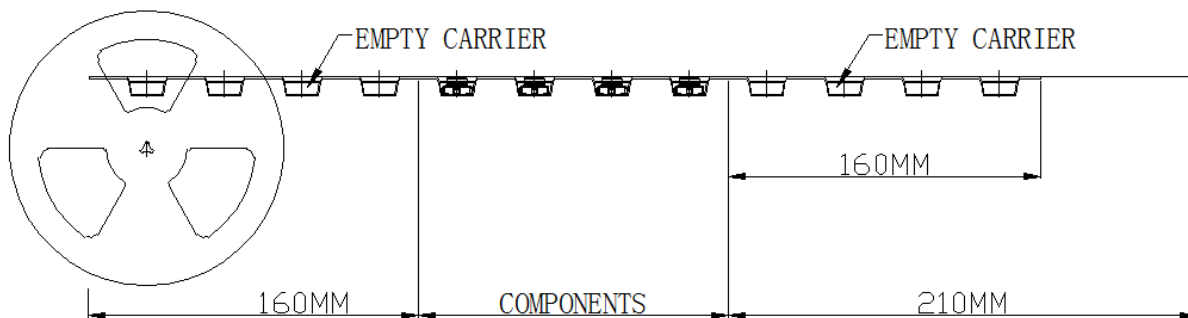
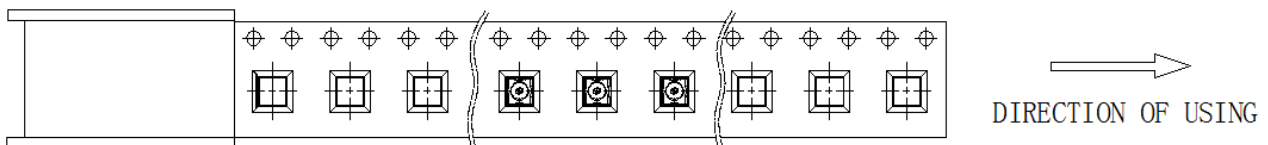
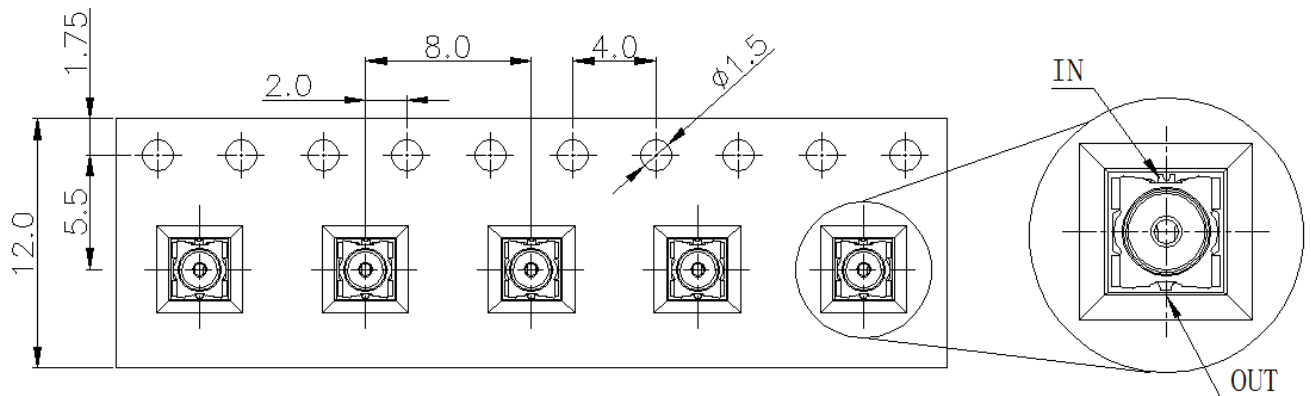

# Product Specification

深圳市金航标电子有限公司  
SHENZHEN KINGHELM ELECTRON CO.,LTD.

**P/N:**

KH-252515-G2.2

**Rev.:**

X1

**Page:**

14/15

## 14. Usage Precaution 使用禁忌或注意事项

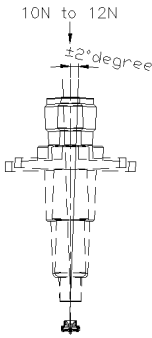
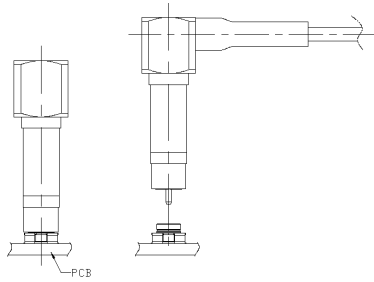
No	Items 项目	Matter 事项
14.1	<b>Connection/ disconnection of connectors</b> 连接器的连接 和断开	<p>a). To mate the connectors, the mating axis of both connectors must be aligned and the connectors can be mated fully, until they can't be moved. Not allowed in a very tilt mating angle and do not bend coaxial cable in the measuring procedure, otherwise you'll get a not good test data.</p> <p>b). To disconnect connectors, please disengage them along the axis direction of mating hole, until they're separated completely. With the point of insertion of allowed and when force is applied as shown in Figure 6</p> <p>a). 公母头连接器进行配合前, 务必确保两者对齐, 对插到死点位置为止, 表示两者已完全配合在一起, 不要以极偏的角度插配连接器, 测试使用过程中, 请不要将同轴线折弯, 否则可能会影响测试效果。</p> <p>b) 断开时请尽量沿配合开口的轴向方向竖直拔起, 线端公头直至两者完全脱离为止, 对插时允许的配合角度和施加力如图 6 所示。</p> <div style="display: flex; justify-content: space-around;"> <div style="text-align: center;"> <p>Type A:</p>  </div> <div style="text-align: center;"> <p>Type B/C:</p>  </div> </div>

**Figure 6**

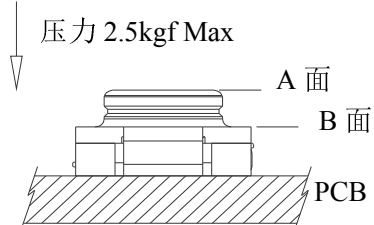
No	Items 项目	Matter 事项
14.2	<b>Precautions 禁忌</b>	<p>a) Please mount this product at the position so that stress by wrap and/or bend of the PCB may not apply to it.</p> <p>b) Please avoid the cleaning of this product</p> <p>c) The product can't be in the longtime compression and the pressure on surface no more than 2.5Kgf. Please refer to figure 7</p> <p>a) 产品安装位置处不应有 PCB 翘曲和/或弯曲施加应力。</p> <p>b) 请避免清洁此产品</p> <p>c) 产品表面所承受压力最大不能超过 2.5 Kgf, 且不能处于长久受压状态. 请参照图 7 所示。</p> <div style="text-align: center;">  </div>

**Figure 7**

# Product Specification

深圳市金航标电子有限公司  
SHENZHEN KINGHELM ELECTRON CO.,LTD.

P/N:

KH-252515-G2.2

Rev.:

X1

Page:

15/15

14.3

Stockpile  
condition  
存储条件

Use this product within 6 months after receipt  
Condition : Temp:  $-10^{\sim}+40^{\circ}\text{C}$  Humidity:15~85%

有效期: 请在产品接收后的 6 个月内使用  
存储环境: 温度: $-10^{\sim}+40^{\circ}\text{C}$ ; 湿度:15%~85%

## X-ON Electronics

Largest Supplier of Electrical and Electronic Components

*Click to view similar products for [RF Connectors / Coaxial Connectors](#) category:*

*Click to view products by [Kinghelm](#) manufacturer:*

Other Similar products are found below :

[8915-1511-000](#) [89674-0827](#) [6002-7051-003](#) [6059674-1](#) [630059-000](#) [M39030/3-01N](#) [6501-1071-002](#) [6769](#) [7002-1572-002](#) [7003-1542-011](#)  
[7003-1572-002](#) [7004-1512-000](#) [7009-1511-004](#) [7101-1541-010](#) [7105-1521-002](#) [7145-1521-002](#) [7203-1571-003](#) [7209-1511-011](#) [7210-1511-](#)  
[040](#) [7242-1511-000](#) [73216-2241](#) [73404-2300](#) [7405-1521-005](#) [7405-1521-802](#) [8527](#) [8547](#) [FS11V](#) [8808-1511-001](#) [9074-9513-000](#) [PL11C-](#)  
[026](#) [PL40-5](#) [PL71-9](#) [PL74C-221](#) [9408-1113-000](#) [980-8666-005](#) [1200690078](#) [1-201144-1](#) [120919](#) [R107003010W](#) [R112186000](#)  
[R113053000W](#) [R113082097](#) [R113236000](#) [R113240000](#) [R113240097](#) [R114083000](#) [R114670000W](#) [R123415000W](#) [R124072220W](#)  
[R124076320](#)