

	Product Specification	DOC. No.: 651-0417-01	Rev.: C	Page: 1/12
	P/N: KH-272716-2.2	Approved/Date SAM 06/22'18	Check/Date SAM 06/22'18	Design/date Star.Hu 06/22-18'

1. Application (应用):

This products are designed for Characteristic measurement in the Mobile phones, W-LAN M, Microwave equipments, etc, application.

该系列产品设计用于移动电话, W-LAN, 其它无线和测量设备等领域电路的特性测量。

2. Scope(范围):

This specification covers the requirements for product performance, test methods and quality assurance provisions of Mini RF II Switch Connectors.

本规范内容包括第二代 Mini RF 开关型同轴连接器的产品性能、测试方法及品质保证方面的要求。

3. Technology Parameters (技术参数)

3.1 Frequency Range(频率范围)	DC~6GHz
3.2 Nominal Characteristic Impedance (特征阻抗)	50 +/-5 Ohm
3.3 Operating Temperature Range (工作温度范围)	-40°C ~ +85°C
3.4 Operating Humidity (工作湿度)	95% R.H.MAX

4. Ratings (额定性能要求)

4.1 Voltage Rating (额定电压)	250VAC (R.M.S)
4.2 Initial Insulation Resistance (绝缘电阻)	500 M Ohm
4.3 Withstand Voltage (耐电压)	300V AC 1 Min.

5. Electrical Performance(电性性能)

No	Items (项目)	Test Condition (测试条件)	Specifications (规格)
5.1	Contact Resistance (接触电阻)	(IEC512-2-1(2a) Testing by the voltage dropping method with the low level current. 按低电平压降方式测量电阻值. Open circuit voltage/放电电压: 20mV MAX Circuit current/电流: 100mA MAX Note:Body Res.is included.测试包括体电阻	1).Center conductor : 120 m Ω Max. 2)Outer shell : 120 m Ω Max.
5.2	Insulation Resistance (绝缘电阻)	Mate the plug and receptacle connector together, and then, apply DC 250 V +/-25 V Duration : 1 min Voltage between the inner contact and the ground contact in accordance with IEC 512-4-1(3a), 按照 IEC 512-4-1(3a),将公母头配合在一起,然后在内导体和拉地端之间施加 250V DC 的电压,然后,进行相关的测试。	500 MΩ MIN

		Product Specification		DOC. No.: 651-0417-01	Rev.: C	Page: 2/12
		P/N: KH-272716-2.2	Approved/Date SAM 06/22'18	Check/Date SAM 06/22'18	Design/date Star.Hu 06/22-18'	

	5.3	Dielectric withstanding voltage (耐电压)	IEC 512-4-1(4a) Testing by applying the specified voltage between inner and outer conductor. Voltage: AC 300 V +/-20V r.m.s. Duration : 1 min. 按照 IEC 512-4-1(4a)标准,在内导体和接地外导体之间施加 300V AC 的电压,并进行相关测试。	No flashover, No sparkover, No excess leakage, No breakdown 无瞬断、熔闪、漏电、击穿。
	5.4	V.S.W.R (电压驻波比)	Measure the V.S.W.R as shown in figure 1 by the network analyzer Frequency: DC~6GHz 通过网络分析仪测试 V.S.W.R, 频率范围为 DC~6GHz.如图 1 所示。	1.2 Max. (DC~3GHz); 1.3 Max. (3~6GHz);
	5.5	Insertion Loss (插入损耗) -开关 ON 态	Measure the Inertion Loss as shown in figure 2 by the network analyzer Frequency: DC~6GHz 通过网络分析仪测试插损, 频率范围为 DC~6GHz.如图 2 所示。	-0.1dBMax. (DC~3GHz); -0.2dBMax. (3~6GHz);

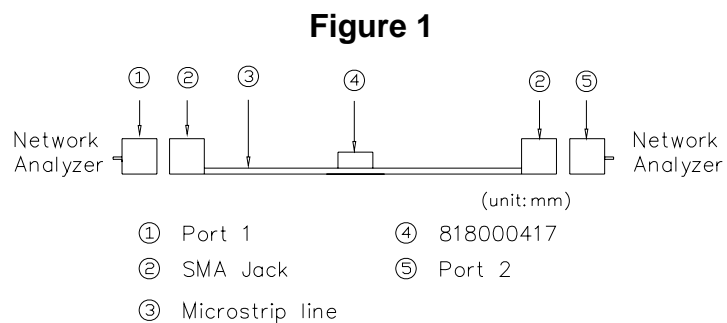

	Product Specification	DOC. No.: 651-0417-01	Rev.: C	Page: 3/12
	P/N: KH-272716-2.2	Approved/Date SAM 06/22'18	Check/Date SAM 06/22'18	Design/date Star.Hu 06/22-18'

		Figure 2	
		<p style="text-align: center;">(unit: mm)</p> <p>① Port 1 ④ 818000417 ② SMA Jack ⑤ Port 2 ③ Microstrip line</p>	
5.6	Isolation (隔离度) -开关 OFF 态	<p>Measure the Isolation as shown in figure 3 by the network analyzer Frequency: DC~6GHz 通过网络分析仪测试隔离度，频率范围为DC~6GHz.如图 3 所示。</p>	<p>20dBMin. (DC~3GHz); 15dBMin. (3~6GHz);</p>
		Figure3	<p style="text-align: center;">(unit: mm)</p> <p>① Port 1 ④ 818000417 ② SMA Jack ⑤ Termination ③ Microstrip line ⑥ Probe for automatic measurement ⑦ Port 2</p>

6. Mechanical Performance(机械性能)

No	Items (项目)	Test Condition (测试条件)	Specifications (规格)
6.1	Mating/Un-mating Force (插拔力)	<p>IEC 512-15-4(15d) A.Mating Force Measuring the required force for complete mated to the mated connector at 25±3mm/minutes. B.unmating Force Measuring the required force for complete unmating from the mated connector at 25±3mm/minutes. 将公母座完全配合到位并测试要求的插入力； 将公母座分离到完全分开位置并测试要求的拔出力， 速率：每分钟 25±3 毫米。</p>	<p>1.Mating Force (插入力): 30N(3Kgf) Max 2.Unmating Force (拔出力): 5~40N (0.5~4Kgf)</p>

Product Specification		DOC. No.: 651-0417-01	Rev.: C	Page: 4/12
		Approved/Date	Check/Date	Design/date
P/N: KH-272716-2.2		SAM 06/22'18	SAM 06/22'18	Star.Hu 06/22-18'

6.2	Allowed Push Force (接触压力)	<p>Push the conn.switch from on-state to off-state. Gauge for automatic measurement is used and the insertion force which is needed to get 15dB isolation at 6GHz while 15dB isolation at 3GHz is measured .as shown in Figure 4 with the required force along the axis direction.</p> <p>如图 4 所示，用标准试验针测试轴向力下压开关的动弹片,使开关断开,并使 3GHz 的隔离度为 20dB;6GHz 隔离度为 15dB 时测试所施加的力。</p>	3.4~4.5N (0.34~0.45Kgf)
		Figure4 	
6.3	Durability (机械寿命)	<p>Mate and un-mate the receptacle connector(soldered to the test board) and plug connector 30 cycles at the speed of 25±3mm/minutes along the mating direction by the push-push machine</p> <p>将母座焊接在测试板上，然后，通过插拔力测试仪沿配合方向以每分钟 25±3 毫米的速度插拔公母头 500 个循环，然后测试参数。</p>	<p>Appearance: No abnormality</p> <p>Contact Resistance: Shall meet 5.5.1</p> <p>Mating/unmating force meet 6.6.1</p> <p>外观：无损伤</p> <p>接触电阻：满足节 5.5.1 要求</p> <p>插拔力满足 6.6.1</p>
6.4	Adhered of Electrode Terminal (焊点粘接力)	<p>Soldering test sample with test PCB.Measure Recording to figure 5 under condition as following.</p> <p>将产品焊在 PCB 上,按图 5 方式在下述条件下测量:</p> <p>1. Force(拉力):50N 2.Time(时间):5+/-1s.</p>	<p>The board adhesion force shall be 5000 grams min.</p> <p>焊点粘接力大于 5Kgf。</p>

	Product Specification	DOC. No.: 651-0417-01	Rev.: C	Page: 5/12
	P/N: KH-272716-2.2	Approved/Date SAM 06/22'18	Check/Date SAM 06/22'18	Design/date Star.Hu 06/22-18'

Figure 5

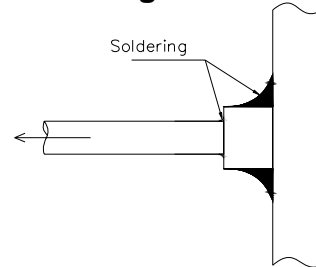

6.5	Vibration (振动)	<p>IEC 512-6-4(6d) Apply the following vibration to the mating connector. During the testing,run 100mA DC to check electrical discontinuity. Frequency:10Hz →100Hz→30Hz/approx 20minutes. Half amplitude,Peak value of acceleration: 3mm or 60m/s² (6G) Directions,cycle:3 mutually perpendicular direction,3 cycles about each direction 将公母头配合，并施加如下条件测试。在测试期间,施加 100mA DC 电压,并检验电不连续性。 频率: 10Hz→ 100Hz→ 10Hz/约 20minutes. 半振幅、加速度: 3mm、60 m/s² (6G) 方向和循环次数: 每个互相垂直方向上进行 3 次测量。</p>	<p>Appearance:No abnormality CenterContact Res.:Shall meet 5.5.1 Nodiscontinuities of 10 μ s or longer duration</p> <p>外观:无损伤 中导体接触电阻:满足节 5.5.1 的要求, 电不连续性不超过 10 μ s。</p>
6.6	Shock (机械冲击)	<p>IEC 512-6-3(6c) The object of this test procedure is to detail a standard method to assess the ability of a connector to withstand specified severity of mechanical shock.Test Current:100mA. 此测试程序的目的是要作一详细标准以评估连接器能承受特定严格机械冲击的能力。 Peak value of acceleration:750m/s² (75G) Duration :6ms Wave form : half sinusoidal Directions,cycle : 6 mutually perpendicular direction, 3cycles about each direction 振幅峰值, :750m/s² (75G) 持续时间: 6 毫秒 波型: 半正弦波 方向和循环次数: 每 6 个相互垂直方向上各进次 3 次。通电 100mA 测试电不连续性。</p>	<p>Appearance:No abnormality CenterContact Res.:Shall meet 5.5.1 Nodiscontinuities of 10 μ s or longer duration</p> <p>外观:无损伤 中导体接触电阻:满足节 5.5.1 的要求, 电不连续性不超过 10 μ s。</p>

	Product Specification	DOC. No.: 651-0417-01	Rev.: C	Page: 6/12
	P/N: KH-272716-2.2	Approved/Date SAM 06/22'18	Check/Date SAM 06/22'18	Design/date Star.Hu 06/22-18'

7. Environmental Performance(环境性能)

No	Items (项目)	Test Condition (测试条件)	Specifications (规格)
7.1	Humidity (湿度试验)	<p>Test is done without mating adaptor ,apply the following environment to the mating connector in accordance with IEC 512-11-3(11c)</p> <p>Temperature : 60°C Humidity : 95%R.H Duration: 96 hours(50hours*) Note: The condition is under the “*”value when test is done with adaptor. Measurements should be done within 2hours.</p> <p>在未用转接器插合状态下，根据 IEC 512-11-3(11c)方法,对已配合的连接器施加下列条件测试. 温度: 60°C 湿度: 95%R.H 持续时间: 96 小时(50 小时*) 备注: 1)在有转接器插合状态下测试时间为“*”值。2)所有测量应在完成湿度试验 2 小时内进行。</p>	<p>Appearance: No abnormality Contact Resistance: Shall meet 5.5.1 Insulation Resistance: Shall meet 5.5.2 Dielectric withstanding voltage Shall meet 5.5.3</p> <p>外观:无损伤 接触电阻:满足 5.5.1 绝缘电阻:满足 5.5.2 耐电压:满足 5.5.3</p>
7.2	Thermal Shock (冷热冲击)	<p>Apply the following environment to the mating connector in accordance with IEC 512-11-4(11d) Test Condition :</p> <p>-50°C(30min)~25°C(5max) ~ 90°C(30min) ~ 25°C(5max) Transition time: : 5min. MAX Cycles: 50 Cycles</p> <p>根据 IEC 512-11-4(11d), 按如下试验条件对已配合的连接器施加下列条件测试. 循环: -50°C(30min)~25°C(5max)~90°C(30min) ~ 25°C(5max) 转换时间: 5 min Max. 循环次数: 50 次数</p>	<p>Appearance: No abnormality Contact Resistance: Shall meet 5.5.1 Insulation Resistance: Shall meet 5.5.2 Dielectric withstanding voltage Shall meet 5.5.3</p> <p>外观: 无损伤 接触电阻: 满足节 5.5.1 中的要求 绝缘电阻: 满足节 5.5.2 中的要求 耐电压: 满足节 5.5.3 中的要求</p>

		Product Specification		DOC. No.: 651-0417-01	Rev.: C	Page: 7/12
		P/N: KH-272716-2.2	Approved/Date SAM 06/22'18	Check/Date SAM 06/22'18	Design/date Star.Hu 06/22-18'	
	7.3	solderability (可焊试验)	<p>Apply the following environment to the mating connector</p> <p>Temperature : 245±2℃</p> <p>Duration : 3~5 second</p> <p>Test sample should be observed by the magnification of 10times after the test.</p> <p>按下列条件对已配合的连接器进行测试.</p> <p>温度: 245+/-2℃</p> <p>持续时间:3~5 秒钟.</p> <p>观测: 10 倍放大镜</p>	At least 95% covered by a continuous new solder coating. 吃锡面积大于 95%以上。		
	7.4	Resistance to soldering heat (耐焊接热试验)	<p>According to 10.10.1,Apply reflow soldering condition.</p> <p>Measurement after 24h+/-2h.</p> <p>IR Refloe CYCLE:2cycles</p> <p>按 10.10.1 中曲线条件进行回流焊接,并在 24 小时后进行相关测试.</p> <p>过炉: 2 次</p>	<p>Appearance: No abnormality</p> <p>Contact Resistance: Shall meet 5.5.1</p> <p>Insulation Resistance: Shall meet 5.5.2</p> <p>Dielectric withstanding voltage Shall meet 5.5.3</p> <p>solder tail: Before IR:0.08mmMAX</p> <p>After IR:0.10mmMAX</p> <p>外观:无损伤接触电阻: 满足节 5.5.1 中的要求</p> <p>绝缘电阻:满足 5.5.2 中的要求</p> <p>耐电压:满足节 5.5.3 中的要求</p> <p>过炉前: 0.08mm.最大</p> <p>过炉后: 0.10mm.最大</p>		
	7.5	Salt Spray (盐雾测试)	<p>IEC 512-11-6(11f)</p> <p>Apply the following environment to the mating connector</p> <p>Temperature : 35±2℃</p> <p>Relative Humidity : 90~98%R.H</p> <p>Salt water density: 5±1%</p> <p>Duration :Inner contact(中心导体接触区) 48 hours</p> <p>Ground contact(外导体) 24 hours</p> <p>根据 IEC 512-11-6(11f)中的要求,,对已配合的连接器的施加下列条件测试.</p> <p>温度: 35±2℃ ;相对湿度: 90~98%R.H</p> <p>盐水浓度: 5±1%</p>	<p>Appearance: No abnormality</p> <p>Contact Resistance: Shall meet5.5.1</p> <p>外观: 无损伤</p> <p>接触电阻: 满足节 5.5.1 中的要求的</p>		

	Product Specification	DOC. No.: 651-0417-01	Rev.: C	Page: 8/12
	P/N: KH-272716-2.2	Approved/Date SAM 06/22'18	Check/Date SAM 06/22'18	Design/date Star.Hu 06/22-18'

8. Profile Dimensions(外形规格)

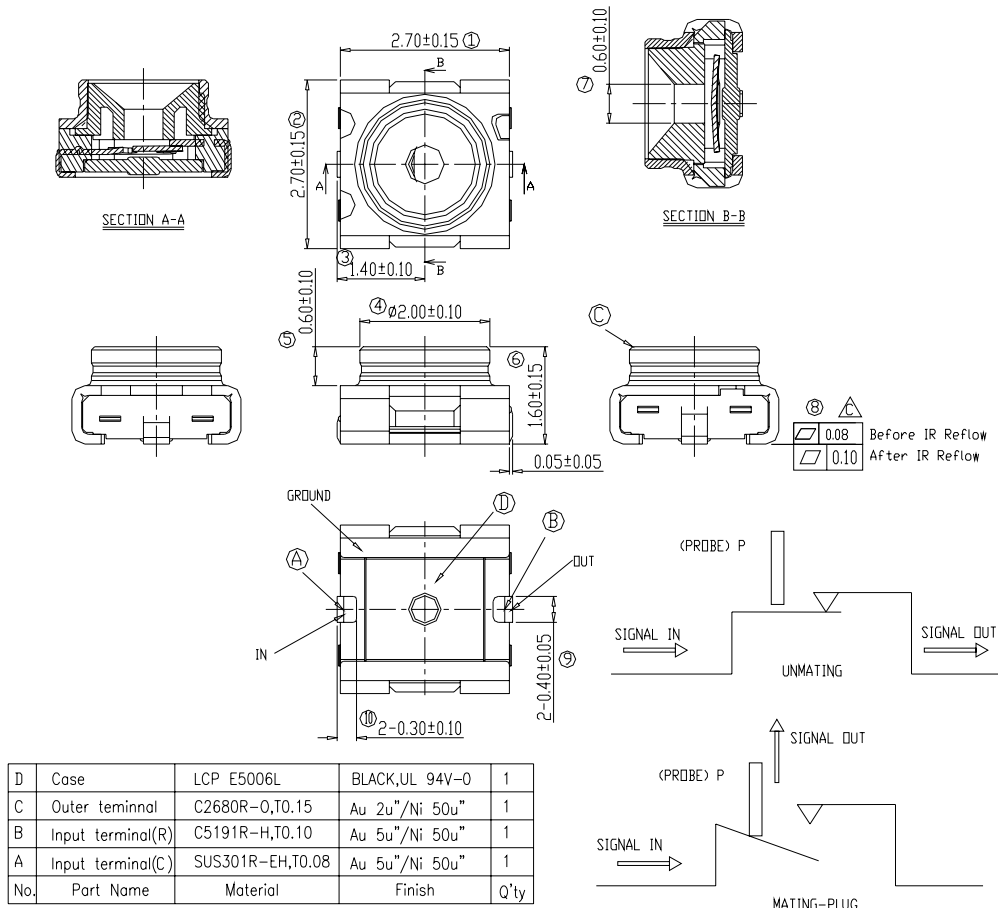

9.Recommmended PCB LAYOUT(推荐的 PCB 安装焊盘规格)

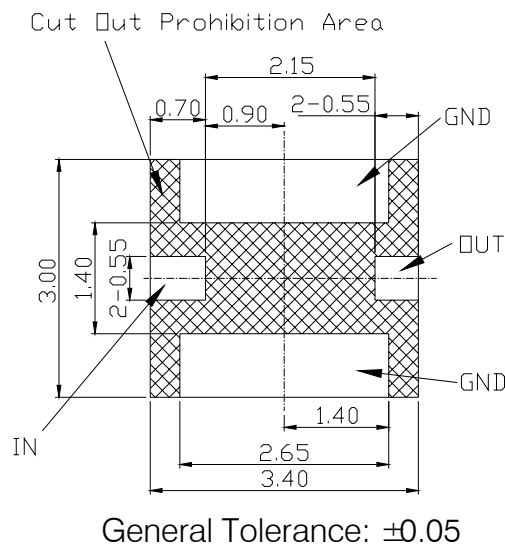

	Product Specification	DOC. No.: 651-0417-01	Rev.: C	Page: 9/12
	P/N: KH-272716-2.2	Approved/Date SAM 06/22'18	Check/Date SAM 06/22'18	Design/date Star.Hu 06/22-18'

10. Recommended Reflow Soldering Condition (SMT 温度曲线图)

10.1 Recommended Temp. & Time of Reflow Soldering
建议回流焊温度与时间条件

10.2 Reflow Soldering Standard Conditions
回流焊极限温度与时间条件

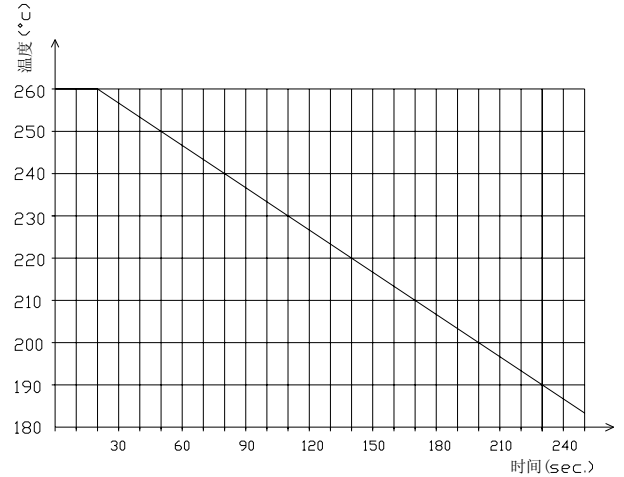
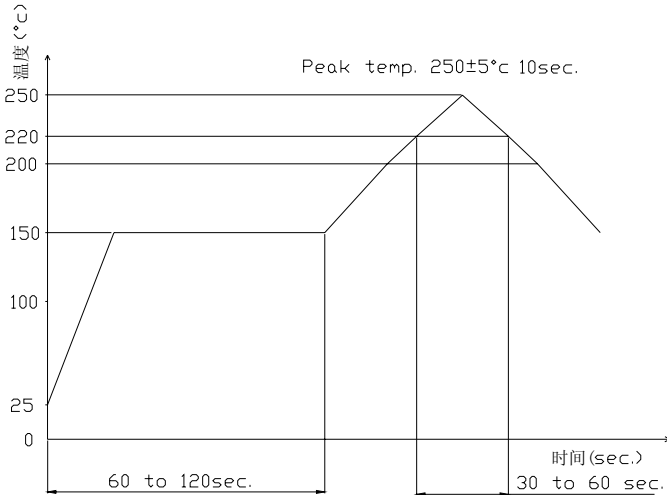

11. Packaging (包装)

13.1 上带的剥离力度: 300mm/min 的速度进行剥离, 力度最大应该是 1.3N

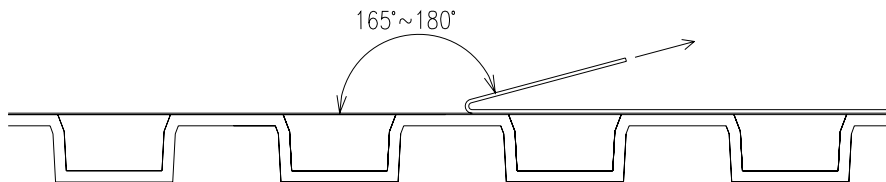

13.2 包装方式: 载带包装, 5000Pcs/卷 (Φ330mm)

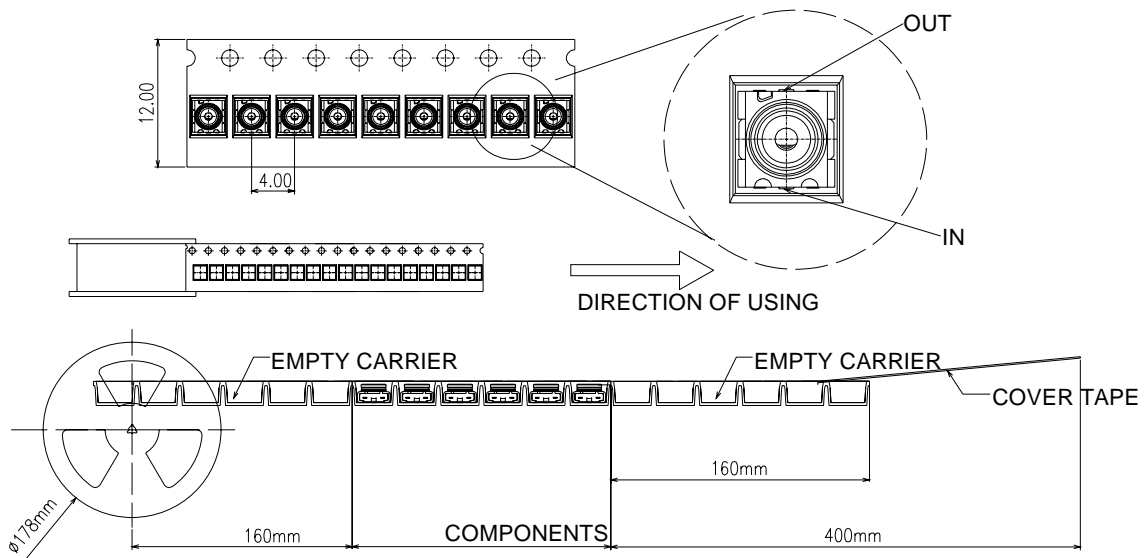

	Product Specification	DOC. No.: 651-0417-01	Rev.: C	Page: 10/12
	P/N: KH-272716-2.2	Approved/Date SAM 06/22'18	Check/Date SAM 06/22'18	Design/date Star.Hu 06/22-18'

12. Usage Precaution (使用禁忌或注意事项)

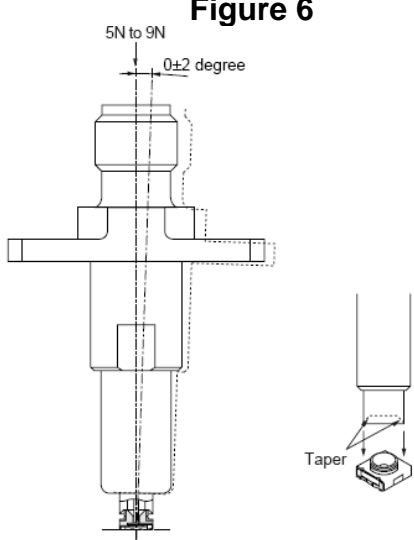
No	Items (项目)	Test Condition (测试条件)	Specifications (规格)
12.1	(1) Connection/ disconnection of connectors 连接器的连接 和断开	<p>1).To disconnect connectors, disengage them along the axis direction of mating hole. 1)尽量沿配合开口的轴向方向将公母头连接器分开。</p> <p>2).To mate the connectors, the mating axis of both connectors must be aligned and the connectors can be mated. The "click" will occur) Allowed mating angle and applied force is as figure6.公母头连接器进行配合前, 务必确保两者对齐, 当听到“卡嗒声”声后, 表示两者已完全配合在一起。不要以极偏的角度插配连接器。 允许的配合角度和施加力如图 6.</p>	
		<p style="text-align: center;">Figure 6</p> 	
12.2	Precautions (禁忌)	<p>Pls mount this product at the position so that stress by wrap and/or bend of the pcb may not apply to it.产品安装位置处不应有PCB 翘曲和/或弯曲施加应力。</p> <p>Pls avoid the cleaning of this product 请避免清洁此产品.</p>	
12.3	Stockpile condition (存储条件)	<p>Use this product within 6 months after receipt 有效期: 请在产品接收后的 6 个月内使用</p> <p>Condition : Temp: -10~+40℃ Humidity:15~85% 存储环境: 温度:-10~+40℃; 湿度:15~85%</p>	

	Product Specification	DOC. No.: 651-0417-01	Rev.: C	Page: 11/12
	P/N: KH-272716-2.2	Approved/Date SAM 06/22'18	Check/Date SAM 06/22'18	Design/date Star.Hu 06/22-18'

13.推荐的测试探针 Accessories for Tests

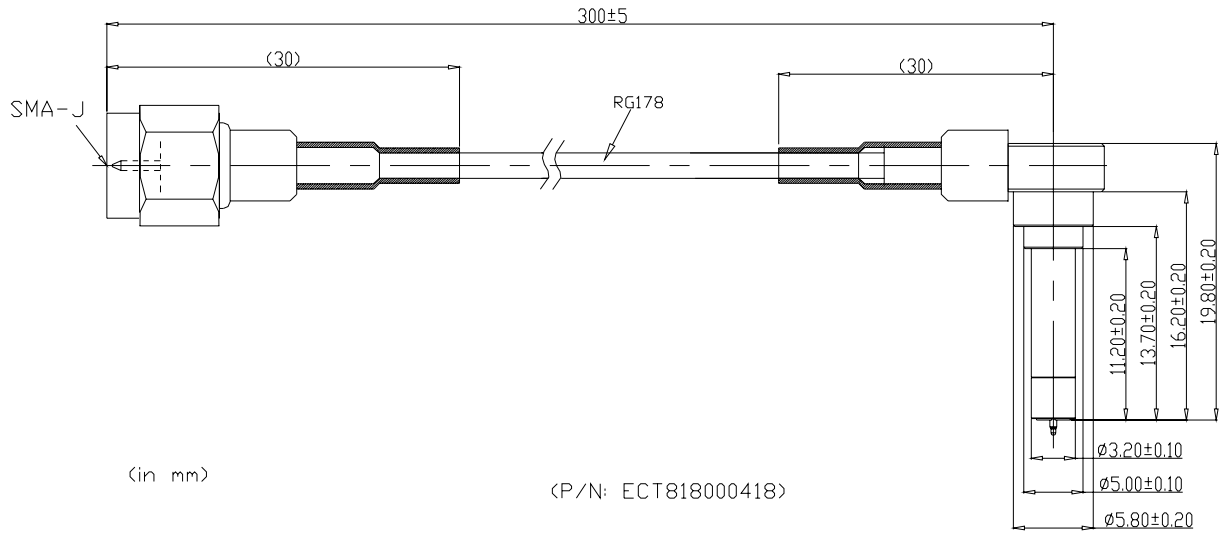

Type II :

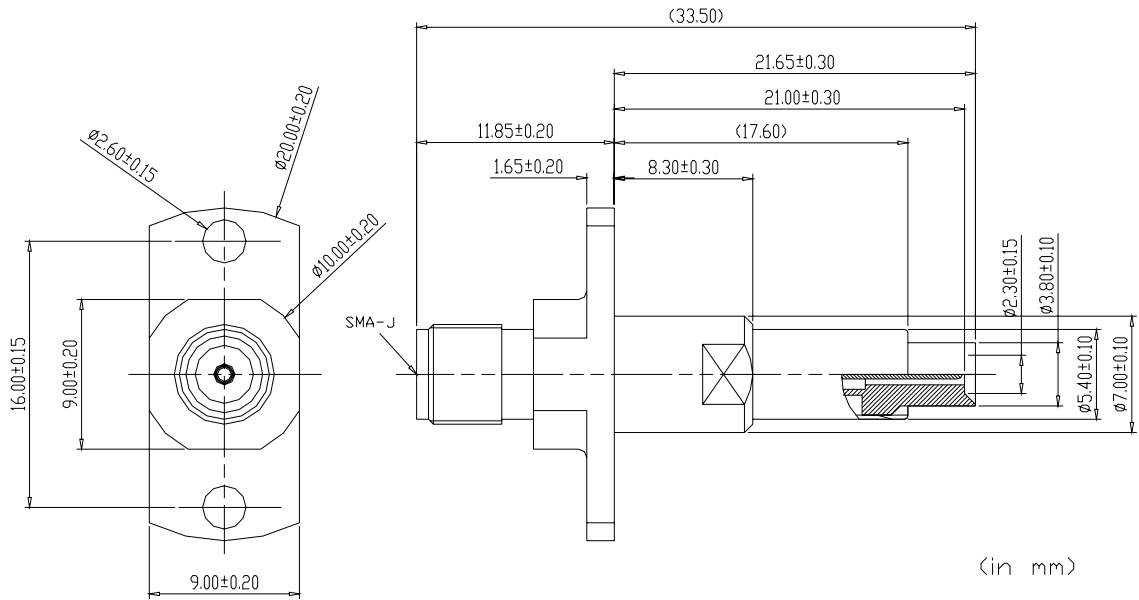

	Product Specification	DOC. No.: 651-0417-01	Rev.: C	Page: 12/12
	P/N: KH-272716-2.2	Approved/Date SAM 06/22'18	Check/Date SAM 06/22'18	Design/date Star.Hu 06/22-18'

14. Test Sequence and Sample Quantity(测试顺序及样品数量)

Test Item (测试项目)	Group (测试分组)											
	A	B	C	D	E	F	G	H	I	J	K	L
Examination of product (外观检测)	1,13	1,4	1,3	1,	1,	1,6	1,6	1,3	1,6	1,5		
Contact Resistance (接触电阻)	2,9			2,4	2,4	2,7	2,7		2,7	2,4		
Insulation Resistance (绝缘电阻)						3,8	3,8		3,8			
Dielectric Withstanding Voltage (耐电压)						4,9	4,9		4,9			
V.S.W.R (电压驻波比)	3,10											
Insertion Loss (插入损耗)	4,11											
Isolation (隔离度)	5,12	2,										
Mating/un-mating Force (插拔力)	6,8											
Allowed Push Force (接触压力)		3,										
Durability (机械寿命)	7,											
Adhered of Electrode Terminal (焊点粘接力)			2,									
Vibration (振动)				3,								
Shock (冲击)					3,							
Humidity (湿度试验)						5,						
Thermal Shock (冷热冲击)							5,					
Solderability (可焊性)								2,				
Resist.to soldering heat (耐焊接热试验)									5,			
Salt Spray (盐雾测试)										3,		
Sample QTY(PCS) 样品数量	5	5	5	5	5	5	5	5	5	5	5	5

The number of group is test sequence 测试分组中的序号为试验顺序。

X-ON Electronics

Largest Supplier of Electrical and Electronic Components

Click to view similar products for [RF Connectors](#) / [Coaxial Connectors](#) category:

Click to view products by [Kinghelm](#) manufacturer:

Other Similar products are found below :

[8915-1511-000](#) [89674-0827](#) [6001-7071-019](#) [6002-7051-003](#) [6059674-1](#) [619550-1](#) [630059-000](#) [M39012/25-3026](#) [M39030/3-01N](#) [6501-1071-002](#) [6769](#) [7002-1541-010](#) [7003-1542-011](#) [7004-1512-000](#) [7009-1511-004](#) [7029-1511-060](#) [7101-1541-010](#) [7101-1571-002](#) [7105-1521-002](#) [7203-1571-003](#) [7209-1511-011](#) [7210-1511-015](#) [7210-1511-040](#) [7242-1511-000](#) [73216-2241](#) [73404-2300](#) [7405-1521-005](#) [7405-1521-802](#) [7406-1521-005](#) [8527](#) [8547](#) [FS11V](#) [877931](#) [8808-1511-001](#) [9049-9513-000](#) [9074-9513-000](#) [910A205F](#) [PL40-36](#) [PL40-5](#) [PL71-9](#) [980-8666-005](#) [1200690078](#) [1-201144-1](#) [120919](#) [R107003010W](#) [R110A172100](#) [R112186000](#) [R113053000W](#) [R113081000](#) [R113082097](#)