

# PART APPROVAL SHEET

APPROAL				CHECK(QA)
RESPONSILITY	TECHNICAL EXPERT	PART LEADER	TEAM LEADER	TEAM LEADER

MODEL NO	PART NAME	PART NO	APPROVAL NO
	MICROPHONE	H9PD1G0002X	



**HJ Automotive Electronics**

# SPECIFICATION FOR APPROVAL

## 承 認 書

Description : Electret Condenserm Microphone

Kingstate Part No. : KECG1530WBL-G01

Customer's Model No. : H9PD1G0002X

Specification No. : MKS-7290

Number Of The Edition : 1.1

### CUSTOMER'S APPROVED SIGNATURE

CUSTOMER'S APPROVED SIGNATURE		



志豐電子股份有限公司 KINGSTATE ELECTRONICS CORP.

Address: 10F, No. 69-11, Sec. 2, Chung Cheng E. Rd., Tamshui County, Taipei Hsien, Taiwan, R.O.C.

International sales dept.: TEL:886-2-2809-5651 FAX:886-2-2809-7151

Domestic sales dept.: TEL:886-2-2809-0668 FAX:886-2-28096748

<http://www.kingstate.com.tw>

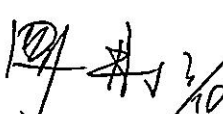
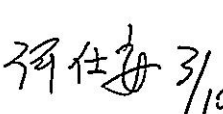
Approved by	Checked by	Issued by
		範成鵬 2022.03.10

# CONTENTS

01-SCOPE/SPECIFICATION.....	Page04
02-TYPICAL FREQUENCY RESPONSE CURVE.....	Page05
03- APPEARANCE DRAWING.....	Page05
04- MEASUREMENT CIRCUIT.....	Page05
05- EXPLOSION DRAWING .....	Page06
06- Dimension of rubber holder.....	Page06
07- MECHANICAL CHARACTERISTICS.....	Page07
08-ENVIRONMENTAL TEST.....	Page07
09- Stock and Transportation.....	Page08
10- PACKING STANDARD.....	Page08
11- PACKING SPECIFICATION.....	Page09
12-Test report& reliability report.....	Page10
13-IMDS report.....	Page11

## A. SCOPE 範疇

This specification applies electret condenser microphone, **KECG1530WBL-G01**

此規格書適用於電容式麥克風 **KECG1530WBL-G01**

## B. SPECIFICATION 規格

No.	Item	Symbol	Unit	Specification	Condition
1	Directivity 方向性			Omnidirectional 全指向	
2	Sensitivity 靈敏度	<b>S</b>	dB	Ⓒ -30± 3	f=1KHz, 1Pa 0dB=1V/Pa
3	Standard operating voltage 標準操作電壓	<b>Vs</b>	V D.C.	2	
4	Output impedance 輸出阻抗	<b>Zout</b>	KΩ	2.2	f=1KHZ, 1Pa
5	operating voltage 操作電壓		V D.C.	1.5~5	
6	Sensitivity reduction 減電壓靈敏度	$\Delta S-Vs$	dB	-3	f=1KHz, 1Pa Vs=2.0V D.C. to 1.5V D.C.
7	Frequency 頻率	<b>f</b>	Hz	100 ~ 20,000	
8	Max. current consumption 最大耗電流	<b>Idss</b>	mA	Ⓒ 0.5	Vs=2.0V D.C. RL=2.2KΩ
9	Signal to noise ration 訊號對雜音比	<b>S/N</b>	dBA	60	f=1KHz, 1Pa A weighted
10	Maximum input S.P.L. 最大音壓		dB	110	
11	Operation temp. 操作溫度		°C	-25 ~ +70	
12	Storage temp. 儲存溫度		°C	-25 ~ +70	
13	Dimension 尺寸		mm	φ 7.2 x 3.7	See appearance drawing 請參照外觀尺寸圖
14	Weight (MAX) 重量		gram	0.36	
15	Material 材質			AL 鋁	
16	Terminal 端子			Wire Type	See appearance drawing 請參照外觀尺寸圖 (Hand Soldering Only)
17	Environmental Protection Regulation 環保法規			RoHS2.0	

We use "Pascal (Pa)" indication of sensitivity as per the recommendation of I.E.C.(International Electro technical Commission).The Sensitivity of "Pa" will increase 20dB comparing with "ubar" indication.

Example: -60dB (0dB=1V/ubar) =-40dB (1V/Pa)

依I.E.C.(國際電子協會)建議,以"Pa"為靈敏度標示單位比"ubar" 靈敏度標示單位增加20dB

例如: -60dB (0dB=1V/ubar) = -40dB (1V/Pa)

**C.TYPICAL FREQUENCY RESPONSE CURVE 頻率響應曲線**

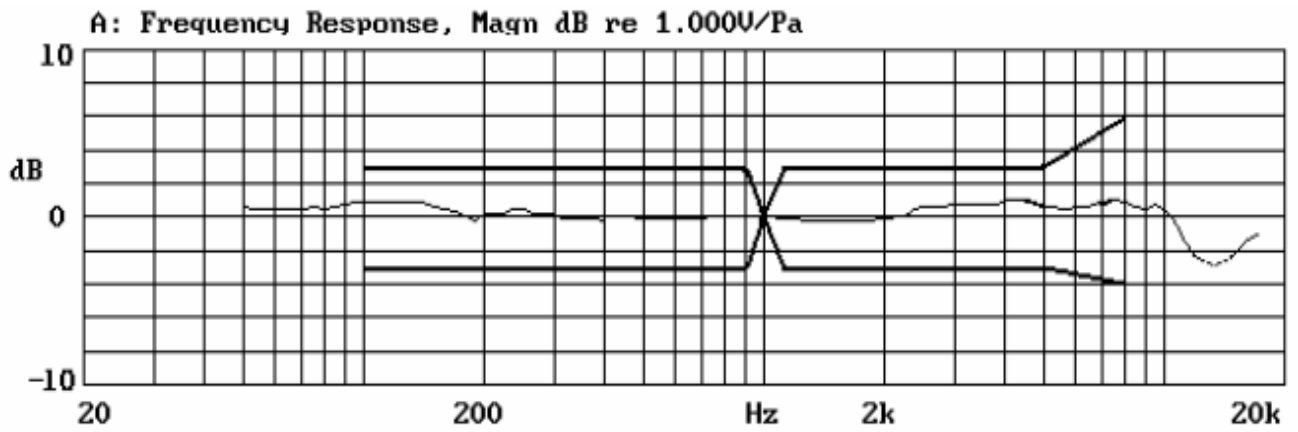

**D. APPEARANCE DRAWING**

外觀尺寸圖

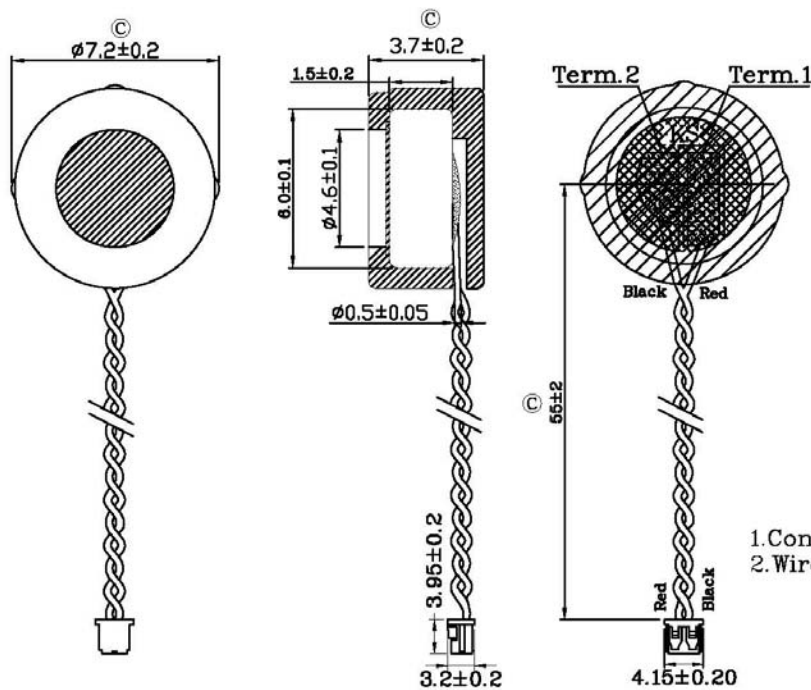

Unit:mm

TOL: ± 0.2

RL=2.2KΩ

**E. MEASUREMENT CIRCUIT**

測量線路

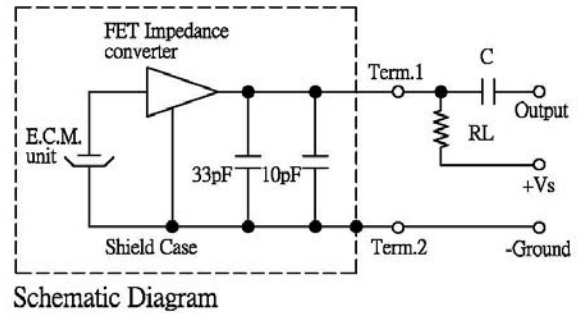

- 1.Connector :12505HS-02(熱縮)
- 2.Wire:UL10212 30AWG

**Fig D-1 EXPLOSION DRAWING 爆炸圖**

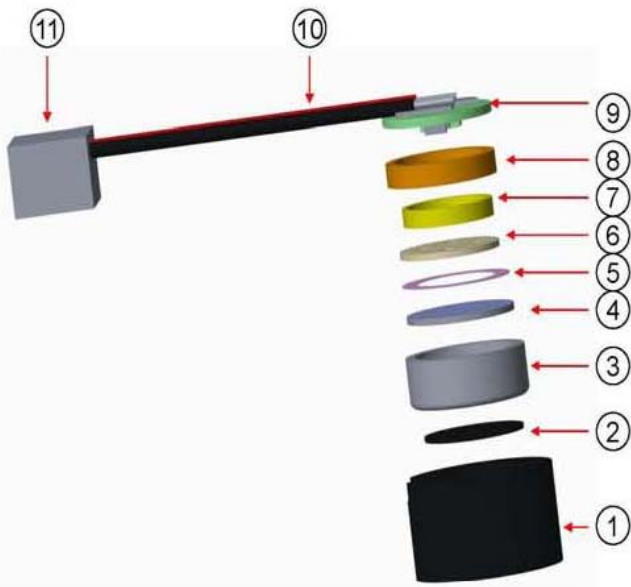

No.	部件 Parts	材質 Material
1	膠套/rubber	Silicone
2	不織布/Non-woven cloth	
3	外殼/case	AL
4	膜片/diaphragm	PPS
5	墊片/spacer	PET
6	背極/back plate	FEP
7	銅環/copper ring	Copper
8	腔體/base	POM
9	加工基板/PCB	FR4
10	線材/Wire	PE
11	連接器/Connector	

**Fig D-2 Dimension of rubber holder**

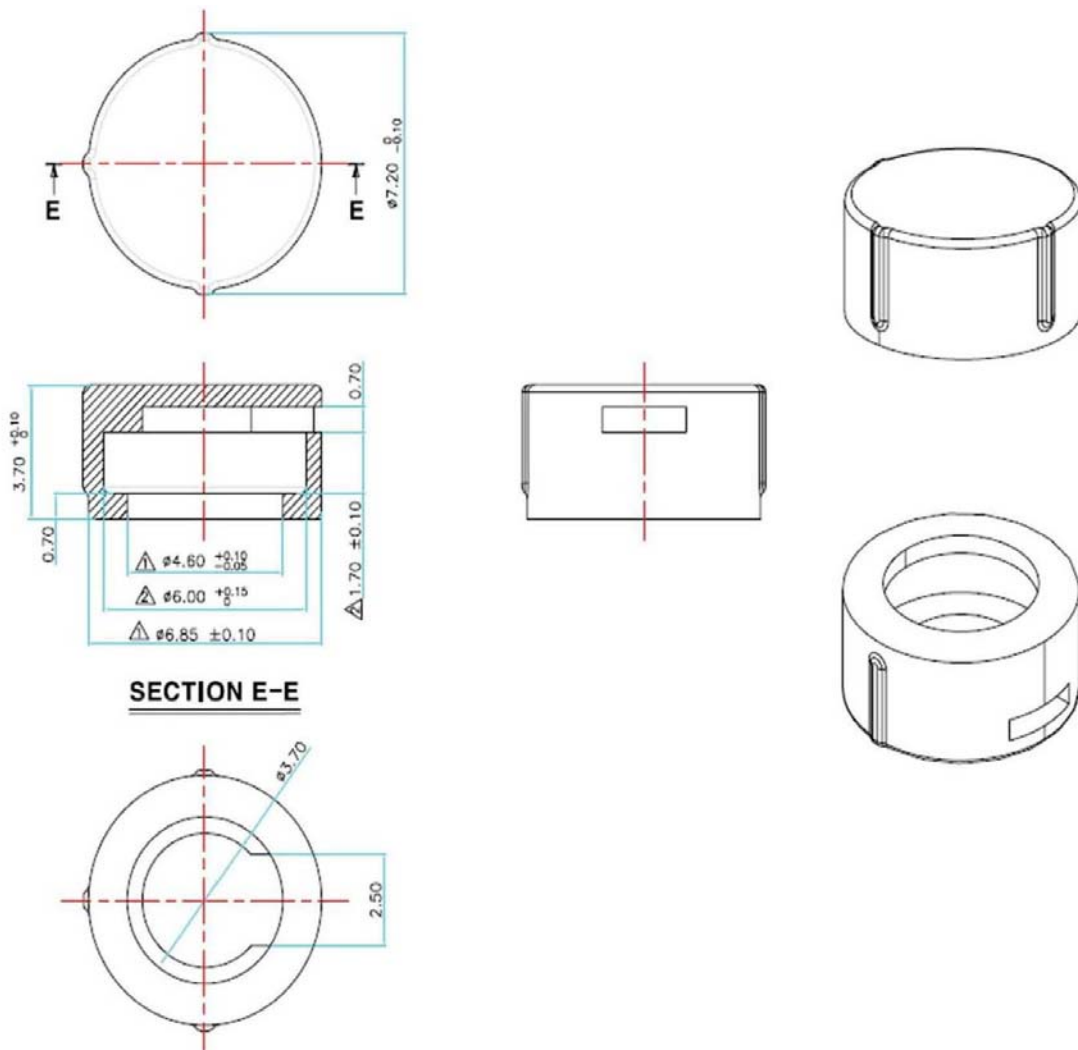

**MATERIAL: Silicone 45 ± 5°(Black)**

**TOL: ± 0.1 Unit:mm**

## F. MECHANICAL CHARACTERISTICS 機械特性

No.	Item	Test Condition	Evaluation standard
1	Solderability 焊錫附著性 (Connector excepted) 端子類不適用此項	Stripped wires of lead wires are immersed in rosin for 5 seconds and then immersed in solder bath of $+270\pm 5^{\circ}\text{C}$ for $3\pm 0.5$ seconds. 裸線部份浸入松香溶液 5 秒後,再浸入 $+270\pm 5^{\circ}\text{C}$ 溶融焊錫槽 $3\pm 0.5$ 秒.	90% min. stripped wires shall be wet with solder.(Except the edge of terminal) 浸入裸線部份附著焊錫 90%以上.(末端斷面不算)
2	Lead Wire Pull Strength 線材拉力	The pull force shall be applied to double lead wire : Horizontal 4.9N(0.5kg) for 30 seconds. 雙線材水平方向施以 4.9N(0.5kg)的力量 30 秒.	No damage and cutting off. 線材不鬆動,不脫落.
3	Vibration 振動試驗	The part shall be measured after being applied vibration of amplitude of 1.52mm with 10 to 55hz band of vibration frequency to each of 3 per-pendicular directions for 2 hours. 振動週波數 10~55HZ、全振幅 1.52mm 於 X.Y.Z 3 個方向,各 2 小時.	After any tests, the sensitivity to be within $\pm 3\text{dB}$ 測試其靈敏度須與原測試值的差異不超過 $\pm 3\text{dB}$ .
4	Drop test 落下測試	The microphone unit without packaged must be subjected to each 3 drops at three axes from the height of 1 meter to 20 mm thick wooden board. 未包裝麥克風單體從 1 公尺高處, X.Y.Z.3 個方向,各 3 回, 落於 20mm 厚木板上.	

## G. ENVIRONMENTAL TEST 環境試驗

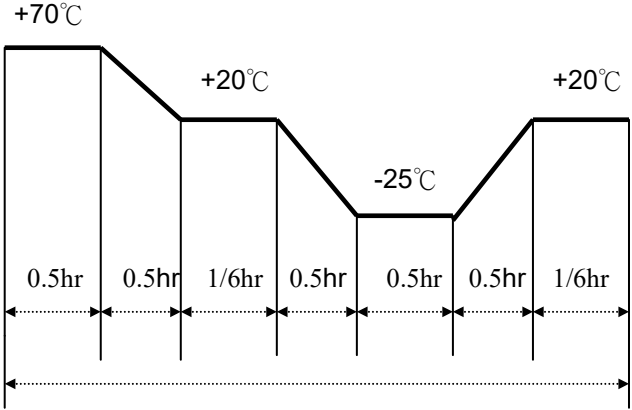
No.	Item	Test conditions	Evaluation standard
1	High temp. test 高溫測試	After being placed in a chamber at $+70^{\circ}\text{C}$ for 200 hours. 置於 $+70^{\circ}\text{C}$ 環境中 200 小時	After any tests, the sensitivity to be within $\pm 3\text{dB}$ of initial sensitivity after 6 hours of conditioning at $+25^{\circ}\text{C}$ 經測試後麥克風,須靜置於 $+25^{\circ}\text{C}$ (室溫)環境中 6 小時後. 測試其靈敏度須與原測試值的差異不超過 $\pm 3\text{dB}$
2	Low temp. test 低溫測試	After being placed in a chamber at $-25^{\circ}\text{C}$ for 200 hours. 置於 $-25^{\circ}\text{C}$ 環境中 200 小時	
3	Humidity test 相對濕度測試	After being placed in a chamber at $+60^{\circ}\text{C}$ and $95\pm 2\%$ relative humidity for 200 hours. 置於 $+60^{\circ}\text{C}$ , 相對濕度 $95\pm 2\%$ 環境中 200 小時	
4	Temp. cycle test 溫度循環測試	The part shall be subjected to 5 cycles. One cycle shall be consist of : 單體承受溫度循環測試 5 次,其循環內容如圖示: 	
5	Temperature shock 溫度衝擊	High Temperature: $+85^{\circ}\text{C}\rightarrow$ Low temperature: $-40\pm 2^{\circ}\text{C} * 30\text{min}\rightarrow$ $\rightarrow$ Test after exposure normal temperature for 2hr	

### TEST CONDITION.

Standard Test Condition : a) Temperature :  $+5 \sim +35^{\circ}\text{C}$  b) Humidity : 45-85% c) Pressure : 860-1060mbar  
 一般測試條件 : a) 溫度 :  $+5 \sim +35^{\circ}\text{C}$  b) 濕度 : 45-85% c) 氣壓 : 860-1060mbar  
 Judgement Test Condition : a) Temperature :  $+25 \pm 2^{\circ}\text{C}$  b) Humidity : 60-70% c) Pressure : 860-1060mbar  
 爭議時測試條件 : a) 溫度 :  $+25 \pm 2^{\circ}\text{C}$  b) 濕度 : 60-70% c) 氣壓 : 860-1060mbar

## H. Stock and Transportation 儲存和運輸

Keep ECM in warehouse with less than 75% humidity and without sudden temperature change, acid air, any other harmful air or strong magnetic field.

The ECM with normal pack can be transported by ordinary conveyances. Please protect products against moist, shock, sunburn and pressure during transportation.

## I. PACKING STANDARD 包裝規格

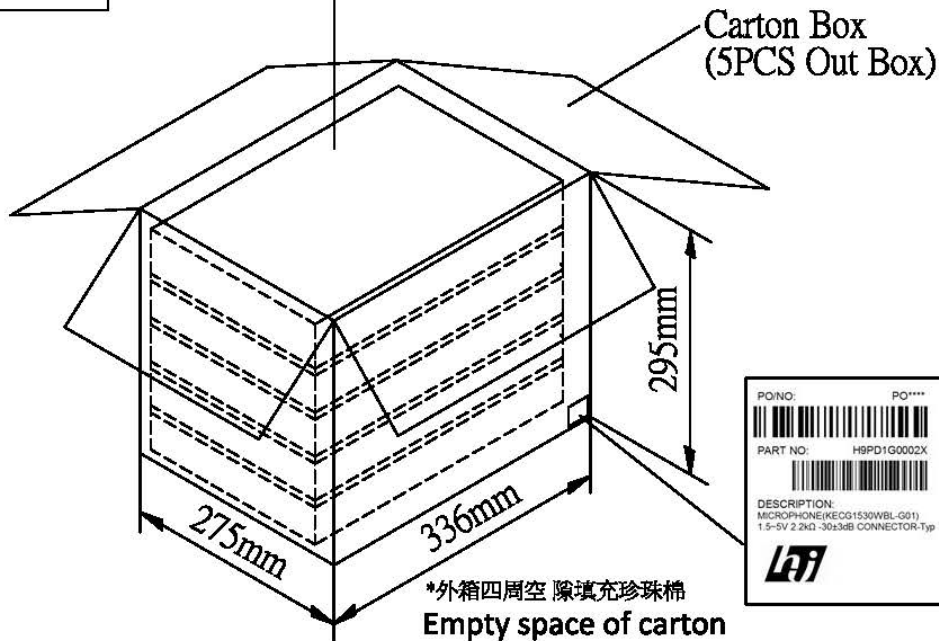
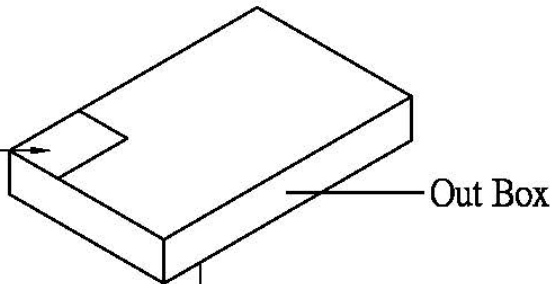
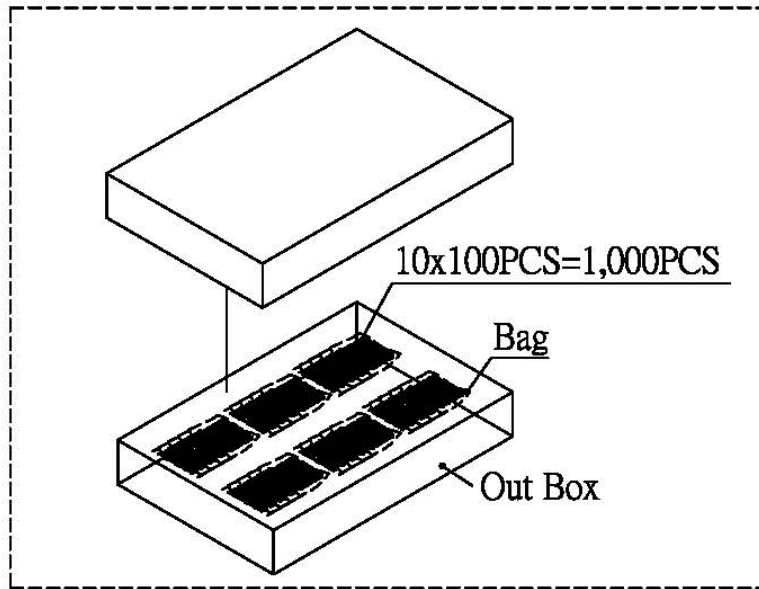

Out Box	310mmx248mmx49mm	1x1000PCS=1000PCS
Carton Box	336mmx275mmx295mm	1000PCSx5=5,000PCS



J . PACKING SPECIFICATION 標籤信息

1) Inner box label 內容原則

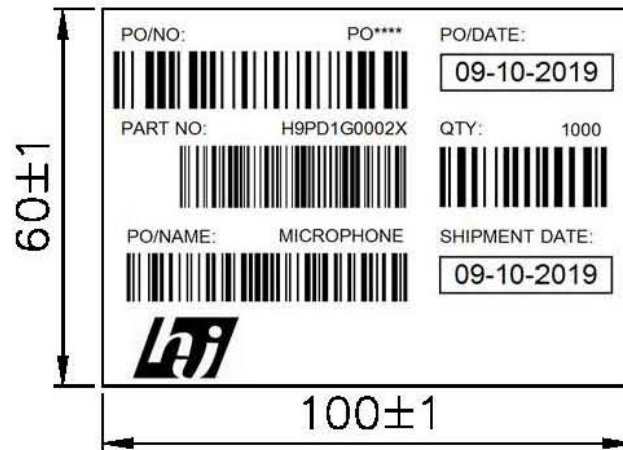

2) Outer box label 內容原則

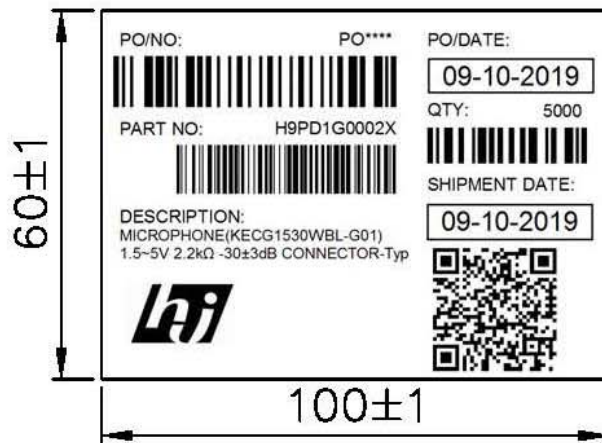

2 Code  
Code No: 128

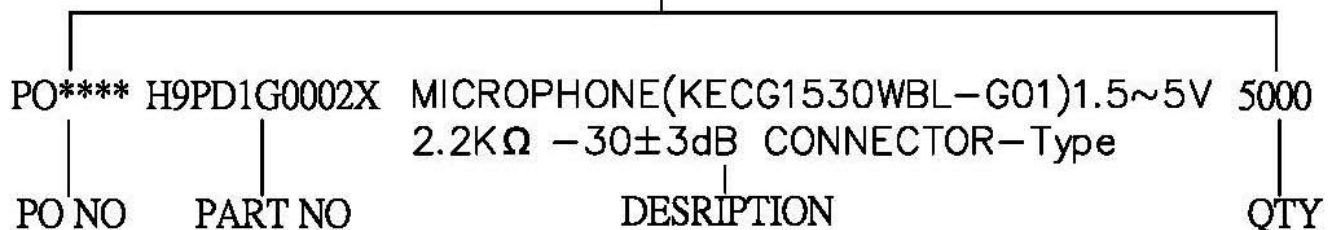



**PERIODIC TEST REPORT**

**周期试验报告**

型号 P/N No.	KECG1530WBL-G01	分类 (TYPE)		依据规范 (CORRESPONDING SPEC.)
测试项目 (TEST ITEM)		判定基准 (JUDGING CRITERIA)		
1、高温试验 HI-Temp. Test 2、低温试验 LOW-Temp. Test 3、恒温恒湿试验 Constant Temp. & Humi. Test 4、温度循环试验 Temperature Recycling Test 5、跌落实验 Dropping Test 6、振动实验 Vibration Test 7、温度冲击实验 Thermal Test		1、技术条件 (SPECIFICATIONS): 2V 2.2KOHM 灵敏度 (Sensitivity): -30+/-3 dB (0dB=1v/Pa at 1KHz) 消耗电流(Current Consumption) (IDS) IDS ≤ 500UA		

测试结果 (RESULT): After testing, the sensitivity should be changed within ±3dB for the initial value.

NO	测试项目 (TEST ITEM)	样品数量 (SAMPLE NO.)	结论 (TEST RESULT)	备注 (REMARK)
	<b>TOTAL SAMPLE NO.</b>	<b>NO.1 ---NO.84</b>	<b>pass</b>	<b>2V 2.2KOHM</b>
1	HI-TEMP.TEST	NO.1 ---NO.12	pass	2V 2.2KOHM
2	LOW-TEMP.TEST	NO.1 ---NO.12	pass	2V 2.2KOHM
3	CONSTANT TEMP. & HUMI.TEST	NO.1 ---NO.12	Pass	2V 2.2KOHM
4	TEMPERATURE RECYCLING TEST	NO.1 ---NO.12	Pass	2V 2.2KOHM
5	Dropping Test	NO.1 ---NO.12	Pass	2V 2.2KOHM
6	Vibration Test	NO.1 ---NO.12	Pass	2V 2.2KOHM
7	Thermal Test	NO.1 ---NO.12	Pass	2V 2.2KOHM

**本次试验合格通过**

(CONFORMITY)

2019年 05月 25日

APPROVED BY: 常建亮

TESTED BY: 高秀雨

**KINGSTATE**

KINGSTATE ELECTRONICS CORP.

<http://www.kingstate.com.tw>**PERIODIC TEST REPORT****例行试验报告**

型号 P/N No.	KECG1530WBL-G01	试验名称 TEST ITEM	高温试验 HI-TEMP. TEST	依据规范 CORRESPONDING SPEC.
测试日期 ( DATE ): 19.05.06		样品数 ( Sample No. ): n= 12 PCS		判定基准 JUDGINGT CRITERIA
使用仪器设备 ( ADOPTED INSTRUMENT )		试验条件 ( TEST CONDITION )		
1、电热恒温干燥箱 (Constant Temp.Drying Cabinet) TYPE : 202 2、声频分析仪 (Acoustic Frequency Analyser) TYPE : CRY6125		1、温度(Temp.): T=+70±2°C 2、试验时间(Lasting Time) :200 hrs 2、恢复时间(Restore Time) : 室温 3hs 3、测试条件(Test Condition) : RL=2.2KOHM Vs=2V		1、技术条件 ( SPECIFICATIONS ) 2V 2.2KOHM 灵敏度 ( SENSITIVITY ): -30+/-3 dB ( 0dB=1v/Pa at 1KHz ) 消耗电流(Current Consumption) ( IDS ) IDS ≤ 500UA

测试结果 ( RESULT ): After testing, the sensitivity should be changed within ±3dB from the initial value.

ITEM NO	SENSITIVITY ( -dB ) at 1KHZ			I <sub>SS</sub> ( μ A )			FREQUENCY RESPONSE	
	INITIAL	FINAL	DIFF.	INITIAL	FINAL	DIFF.	INITIAL	FINAL
1.	-29.1	-31.5	-2.4	230	220	-10	PASS	PASS
2.	-28.1	-30.3	-2.2	200	210	10	PASS	PASS
3.	-30.4	-31.6	-1.2	210	210	10	PASS	PASS
4.	-30.6	-31.3	-0.7	200	210	10	PASS	PASS
5.	-27.2	-29	-1.8	230	220	-10	PASS	PASS
6.	-31.6	-31.7	-0.1	230	220	-10	PASS	PASS
7.	-27.5	-28.3	-0.8	270	255	-15	PASS	PASS
8.	-32.9	-33.7	-0.8	220	230	10	PASS	PASS
9.	-28.4	-31.1	-2.7	200	210	10	PASS	PASS
10.	-32.5	-33.6	-1.1	200	200	0	PASS	PASS
11.	-27.7	-30.2	-2.5	210	200	-10	PASS	PASS
12.	-30.9	-33.2	-2.3	230	230	0	PASS	PASS
MAX	-27.2	-28.3	-0.1	270	255	10		
MIN	-32.9	-33.7	-2.7	200	200	-15		
AVERAGE	-29.74	-31.29	-1.55	235	223	-2.5		
TEST RESULT	OK	OK	OK	OK	OK	OK	OK	OK

APPROVED BY: 常建亮

TESTED BY: 高秀雨



**PERIODIC TEST REPORT**

**例行试验报告**

型号 P/N No.	KECG1530WBL-G01	试验名称 TEST ITEM	低温试验 LOW-TEMP. TEST	依据规范 (CORRESPONDING SPEC)
测试日期 ( DATE ): 19.05.20		样品数 ( SAMPLE SIZE ): n=12 PCS		判定基准 (JUDGING CRITERIA)
使用仪器设备 ( ADOPTED INSTRUMENT )		试验条件 ( TEST CONDITION )		
1、声频分析仪 (Acoustic Frequency Analyzer) TYPE : CRY6125  2、高低恒温箱 (Constant Temp.Cabinet) TYPE : TSE-10		1、温度(Temp.) : T=-25±2°C 2、时间(Lasting Time) : 200 hrs 2、恢复(Restore) : 室温条件下(Ambient):3hrs 4、测试条件(Test condition) : (1)RL=2.2KOHM (2)Vs=2V		
1、技术条件 ( Specifications ) : 2V 2.2KOHM 灵敏度 ( Sensitivity ) : -30+/-3 dB ( 0dB=1w/Pa at 1KHz ) 消耗电流(Current Consumption) ( IDS ) IDS ≤ 500UA				

测试结果 ( RESULT ) : After testing, the sensitivity should be changed within ±3dB from the initial value.

ITEM NO	SENSITIVITY (-dB) at 1KHz			I <sub>loss</sub> ( μ A )			FREQUENCY RESPONSE	
	INITIAL	FINAL	DIFF.	INITIAL	FINAL	DIFF.	INITIAL	FINAL
1.	-29.2	-29.5	-0.3	230	220	-10	PASS	PASS
2.	-30.7	-30.5	0.2	240	245	-5	PASS	PASS
3.	-28.4	-29.9	-1.5	210	200	10	PASS	PASS
4.	-27.4	-28.6	-1.2	260	255	-5	PASS	PASS
5.	-29.7	-29.6	0.1	260	260	0	PASS	PASS
6.	-27.8	-28.9	-1.1	230	230	0	PASS	PASS
7.	-27.2	-28.1	-0.9	250	260	-10	PASS	PASS
8.	-30	-31.2	-1.2	220	210	-10	PASS	PASS
9.	-27.4	-28.4	-1	200	200	0	PASS	PASS
10.	-32.1	-31.2	0.9	240	230	10	PASS	PASS
11.	-29	-29.6	-0.6	235	235	0	PASS	PASS
12.	-32.6	-33.5	-0.9	230	230	0	PASS	PASS
MAX	-27.2	-28.1	0.9	260	260	10		
MIN	-32.6	-33.5	-1.5	210	200	-10		
AVERAGE	-29.29	-29.92	-0.63	235	231	0		
TEST RESULT	OK	OK	OK	OK	OK	OK	OK	OK

APPROVED BY: 常建亮

TESTED BY: 高秀雨



## PERIODIC TEST REPORT

### 例行试验报告

型号 P/N No.	KECG1530WBL-G01	试验名称 TEST ITEM	恒温恒湿试验 Constant Temp.& Humi.Test	依据规范 CORRESPONDING SPEC
测试日期 ( DATE ): 19.05.14		样品数 ( SAMPLE SIZE ): n=12PCS		<b>判定基准</b> (JUDGING CRITERIA)
使用仪器设备 ( ADOPTED INSTRUMENT )		试验条件 ( TEST CONDITION )		
1、恒温恒湿箱 Constant Temp & Humi. Test Cabinet 型号: LH-113  2、声频分析仪 (Acoustical Frequency Analyzer) TYPE: CRY6125		1、温度(Temp.): +60±2°C 2、湿度(Humi.): 93%~97% RH 3、时间(Lasting Time): 200 hrs 4、恢复(Restore) 室温条件下 3hrs 5、测试条件( Test Condition ): (1)RL=2.2KOHM (2)Vs=2V		
				1、技术条件 ( SPECIFICATIONS ): 2V 2.2KOHM 灵敏度 ( SENSITIVITY ): -30+/-3 dB ( 0dB=1v/Pa at 1KHz ) 消耗电流 (Current Consumption) ( IDS ) IDS ≤ 500UA

测试结果 ( RESULT ): After testing, the sensitivity should be changed within ±3dB from the initial value.

ITEM NO	SENSITIVITY ( -dB ) at 1KHz			I <sub>DSS</sub> ( μ A )			FREQUENCY RESPONSE	
	INITIAL	FINAL	DIFF.	INITIAL	FINAL	DIFF.	INITIAL	FINAL
1.	-32.8	-33.9	-1.1	230	220	-10	PASS	PASS
2.	-32	-33.8	-1.8	280	275	-5	PASS	PASS
3.	-29.7	-30.6	-0.9	260	250	-10	PASS	PASS
4.	-29.2	-30.6	-1.4	200	200	0	PASS	PASS
5.	-32.4	-32.7	-0.3	240	240	0	PASS	PASS
6.	-27.3	-30	-2.7	235	235	0	PASS	PASS
7.	-32.1	-33.4	-1.3	290	295	-5	PASS	PASS
8.	-32	-33.7	-1.7	240	240	0	PASS	PASS
9.	-30.1	-31	-0.9	235	235	0	PASS	PASS
10.	-31.7	-32.5	-0.8	240	240	0	PASS	PASS
11.	-30.3	-31.4	-1.1	220	220	0	PASS	PASS
12.	-32	-33.9	-1.9	260	265	-5	PASS	PASS
MAX	-27.3	-30	-0.3	290	295	0		
MIN	-32.8	-33.9	-2.7	200	200	-10		
AVERAGE	-30.97	-32.29	-1.33	245	248	-5		
TEST RESULT	OK	OK	OK	OK	OK	OK	OK	OK

APPROVED BY: 常建亮

TESTED BY: 高秀雨



## PERIODIC TEST REPORT

## 例行试验报告

型号 P/N No.	KECG1530WBL-G01	试验名称 TEST ITEM	温度循环试验 TEMPERATURE RECYCLING TEST	依据规范 CORSPNDG SPEC.
测试日期 ( DATE ) : 19.05.22	样品数 ( SAMPLE SIZE ) : n= 12PCS		判定基准 ( JUDGING CRITERIA )	
使用仪器设 ( ADOPTED INSTRUMENT )	试验条件 ( TEST CONDITION )			
1、高低恒温箱 (HI.& LOW CONSTANT TEMP. CABINET) TYPE : TSE-10  2、声频分析仪 (Acoustic Frequency Analyzer) TYPE : CRY6125	1、循环温度 : (TEMP.Recycling) ( -25°C , 30min ) → ( 20°C , 10min ) → ( 70°C ,30min ) → ( 20°C , 10min ) 循环 5 次 2、恢复(Restore) : 室温下 3hrs(3hours in ambient) 3、测试条件 : (Test condition) RL=2.2KOHM Vs=2V		1、技术条件 ( SPECIFICATIONS ) : 2V 2.2KOHM  灵敏度 ( SENSITIVITY ) : -30+/-3 dB ( 0dB=1v/Pa at 1KHz )  消耗电流(CURRENT CONSUMPTION) ( IDS ) IDS ≤ 500UA	

测试结果 ( RESULT ) : After testing, the sensitivity should be changed within ± 3dB from the initial value.

ITEM NO	SENSITIVITY ( -dB ) at 1KHz			I <sub>loss</sub> ( μ A )			FREQUENCY RESPONSE	
	INITIAL	FINAL	DIFF.	INITIAL	FINAL	DIFF.	INITIAL	FINAL
1.	-31.7	-30.8	0.9	230	230	0	PASS	PASS
2.	-30.4	-30.4	0	230	240	-10	PASS	PASS
3.	-27.5	-28.4	-0.9	240	240	0	PASS	PASS
4.	-28.5	-29.8	-1.3	240	235	-5	PASS	PASS
5.	-27	-28.2	-1.2	210	215	5	PASS	PASS
6.	-28.2	-29.2	-1	230	230	0	PASS	PASS
7.	-32.3	-31.1	1.2	270	270	0	PASS	PASS
8.	-32.7	-33.1	-0.4	220	210	10	PASS	PASS
9.	-29.9	-30.3	-0.4	280	280	0	PASS	PASS
10.	-30.1	-29.3	0.8	270	265	-5	PASS	PASS
11.	-31.9	-32.1	-0.2	240	240	0	PASS	PASS
12.	-29.4	-30.8	-1.4	230	230	0	PASS	PASS
MAX	-27	-28.2	1.2	280	280	10		
MIN	-32.7	-33.1	-1.4	210	210	-10		
AVERAGE	-29.97	-30.29	-0.33	245	245	0		
TEST RESULT	OK	OK	OK	OK	OK	OK	OK	OK

APPROVED BY: 常建亮

TESTED BY: 高秀雨



**PERIODIC TEST REPORT**

**例行试验报告**

型号 P/N No.	KECG1530WBL-G01	试验名称 TEST ITEM	跌落试验 Dropping Test	依据规范 CORSPNDG SPEC.
测试日期 ( DATE ) : 19.05.20		样品数 ( SAMPLE SIZE ) : n= 12PCS		判定基准 ( JUDGING CRITERIA )
使用仪器设 ( ADOPTED INSTRUMENT )		试验条件 ( TEST CONDITION )		
驻极体传声器测试仪 (ECM Testing Device)  TYPE : CRY6125		The microphone unit must be subjected to a procedure that after dropping to concrete floor three times from 1 meter height in state of packing		1.技术条件 ( SPECIFICATIONS ) : 2V 2.2KOHM  2.灵敏度 ( SENSITIVITY ) : -30+/-3 dB ( 0dB=1V/Pa at 1KHz )  3.消耗电流 ( CURRENT CONSUMPTION ) ( IDS ) IDS ≤ 500UA

测试结果 ( RESULT ) : After testing, the sensitivity should be changed within ± 3dB from the initial value.

ITEM NO	SENSITIVITY ( -dB ) at 1KHz			I <sub>SS</sub> ( μ A )			FREQUENCY RESPONSE	
	INITIAL	FINAL	DIFF.	INITIAL	FINAL	DIFF.	INITIAL	FINAL
1.	-32	-32.2	-0.2	180	175	5	PASS	PASS
2.	-31.5	-31.4	0.1	170	170	0	PASS	PASS
3.	-27.9	-28	-0.1	160	165	5	PASS	PASS
4.	-31.6	-31.8	-0.2	175	170	5	PASS	PASS
5.	-32.5	-32.3	0.2	210	210	0	PASS	PASS
6.	-30.5	-30.4	0.1	165	160	5	PASS	PASS
7.	-29.2	-29.2	0	180	185	5	PASS	PASS
8.	-28.3	-28.1	0.2	190	185	5	PASS	PASS
9.	-31.7	-31.9	-0.2	175	170	5	PASS	PASS
10.	-29.7	-29.9	-0.2	200	210	10	PASS	PASS
11.	-28.8	-28.6	0.2	210	200	10	PASS	PASS
12.	-31.9	-31.9	0	205	200	5	PASS	PASS
MAX	-27.9	-28	0.2	210	210	0		
MIN	-32.5	-32.3	-0.2	160	160	10		
AVERAGE	-30.47	-30.48	-0.01	185	183.3	5		
TEST RESULT	OK	OK	OK	OK	OK	OK	OK	OK

APPROVED BY: 常建亮

TESTED BY: 高秀雨



## PERIODIC TEST REPORT

### 例行试验报告

型号 P/N No.	KECG1530WBL-G01	试验名称 TEST ITEM	振动试验 Dropping Test	依据规范 CORSPNDG SPEC.
测试日期 ( DATE ) : 19.05.10		样品数 ( SAMPLE SIZE ) : n= 12PCS		判定基准 ( JUDGING CRITERIA )
使用仪器设 ( ADOPTED INSTRUMENT )		试验条件 ( TEST CONDITION )		
振动仪  驻极体传声器测试仪 (ECM Testing Device)  TYPE : CRY 6125		The microphone unit must be subjected to a procedure that after vibrating for two hours from each of the two directions with a frequency of 10-55Hz and a 1.52mm-high amplitude.		1.技术条件 ( SPECIFICATIONS ) : 2V 2.2KOHM  2.灵敏度 ( SENSITIVITY ) : -30+/-3 dB ( 0dB=1v/Pa at 1KHz )  3.消耗电流 ( CURRENT CONSUMPTION ) ( IDS ) IDS ≤ 500UA

测试结果 ( RESULT ) : After testing, the sensitivity should be changed within ± 3dB from the initial value.

ITEM NO	SENSITIVITY ( -dB ) at 1KHz			I <sub>SS</sub> ( μ A )			FREQUENCY RESPONSE	
	INITIAL	FINAL	DIFF.	INITIAL	FINAL	DIFF.	INITIAL	FINAL
1.	-31.3	-32.1	-0.8	190	190	0	PASS	PASS
2.	-28.5	-28.4	0.1	180	180	0	PASS	PASS
3.	-30.8	-31.0	-0.2	160	165	5	PASS	PASS
4.	-31.5	-31.8	-0.3	175	170	5	PASS	PASS
5.	-27.9	-28.1	-0.2	220	210	10	PASS	PASS
6.	-33	-33.5	-0.5	165	160	5	PASS	PASS
7.	-31.2	-30.4	0.8	180	185	5	PASS	PASS
8.	-32.5	-32.8	-0.3	190	185	5	PASS	PASS
9.	-31.8	-32.0	-0.2	185	180	5	PASS	PASS
10.	-28.5	-28.5	0	200	210	10	PASS	PASS
11.	-31.6	-30.7	0.9	210	200	10	PASS	PASS
12.	-29.6	-30.1	-0.5	205	200	5	PASS	PASS
MAX	-27.9	-28.1	0.9	210	210	0		
MIN	-33	-33.5	-0.8	160	160	10		
AVERAGE	-30.68	-30.78	-0.10	185	183.3	5		
TEST RESULT	OK	OK	OK	OK	OK	OK	OK	OK

APPROVED BY: 常建亮

TESTED BY: 高秀雨





**PERIODIC TEST REPORT**

**例行试验报告**

型号 P/N No.	KECG1530WBL-G01	试验名称 TEST ITEM	温度冲击试验 Dropping Test	依据规范 CORSPNDG SPEC.
测试日期 ( DATE ) : 19.05.29	样品数 ( SAMPLE SIZE ) : n= 12PCS		判定基准 ( JUDGING CRITERIA )	
使用仪器设 ( ADOPTED INSTRUMENT )	试验条件 ( TEST CONDITION )			
高低温交变箱  驻极体传声器测试仪 (ECM Testing Device)  TYPE : CRY 8125	3、循环温度 : (TEMP.Recycling) ( -40°C , 30min ) → ( 85°C , 30min ) 循环 30 次 4、恢复(Restore) : 室温下 3hrs(3hours in ambient) 3、测试条件 : (Test condition) RL=2.2KOHM Vs=2V		1 技术条件 ( SPECIFICATIONS ) : 2V 2.2KOHM 2.灵敏度 ( SENSITIVITY ) : -30+/-3 dB ( 0dB=1v/Pa at 1KHz ) 3.消耗电流(CURRENT CONSUMPTION) ( IDS ) IDS ≤ 500UA	

测试结果 ( RESULT ) : After testing, the sensitivity should be changed within ± 3dB from the initial value.

ITEM NO	SENSITIVITY ( -dB ) at 1KHz			I <sub>DSS</sub> ( μ A )			FREQUENCY RESPONSE	
	INITIAL	FINAL	DIFF.	INITIAL	FINAL	DIFF.	INITIAL	FINAL
1.	-28.9	-30	-1.1	200	195	5	PASS	PASS
2.	-28.6	-30.8	-2.2	170	170	0	PASS	PASS
3.	-28	-28.7	-0.7	160	165	5	PASS	PASS
4.	-28.2	-29.3	-1.1	205	200	5	PASS	PASS
5.	-28.1	-30.8	-2.7	210	210	0	PASS	PASS
6.	-32.2	-34.1	-1.9	165	160	5	PASS	PASS
7.	-29.1	-29.7	-0.6	180	185	5	PASS	PASS
8.	-32.5	-33.7	-1.2	180	185	5	PASS	PASS
9.	-30.2	-31.3	-1.1	175	170	5	PASS	PASS
10.	-29.9	-31.1	-1.2	200	210	10	PASS	PASS
11.	-29.2	-30.6	-1.4	210	200	10	PASS	PASS
12.	-27.7	-28.5	-0.8	170	180	10	PASS	PASS
MAX	-27.7	-28.5	-0.6	210	210	0		
MIN	-32.5	-34.1	-2.7	160	160	10		
AVERAGE	-29.38	-30.72	-1.33	185	183.3	5		
TEST RESULT	OK	OK	OK	OK	OK	OK	OK	OK

APPROVED BY: 常建亮

TESTED BY: 高秀雨

## X-ON Electronics

Largest Supplier of Electrical and Electronic Components

*Click to view similar products for [Microphones](#) category:*

*Click to view products by [Kingstate](#) manufacturer:*

Other Similar products are found below :

[BCM4013OLFC-42-JST-ZHR-2](#) [FG-23329-P142](#) [SPM04C-38/1186-T/R](#) [BCM4013OSBC-42 LF](#) [B6027AP383-056](#) [B4013AM423-092](#)  
[KECG2242CBL-G01](#) [BCM9745-44](#) [BCM9767P](#) [LD-MC-0905P](#) [LD-MC-6035](#) [LD-MC-9765](#) [EM-4015-BC](#) [EM-4530-C](#) [EM-6022S](#) [EM-6027](#) [EM-6050](#) [EM-9745](#) [CMC-4015-40P](#) [PMO-6022SN-42UQ](#) [PMOF-6027WN-44KDQ](#) [PMO-4015PN-42KDQ](#) [CMC-6027-42L100](#) [PMO-6027P-40KDQ](#) [PMOF-6050S-44UQ](#) [PMO-4530PN-47UQ](#) [PMO-4015MN-42HXQ](#) [CMC-6036-40T](#) [CMC-9745-44P](#) [PMOF-9767NP-46DQ](#) [PMOF-9745W-42UQ](#) [PMOF-9745P-39UQ](#) [CMC-6015-42P](#) [PMO-6022PN-48KDQ](#) [PMOF-9745S-42UQ](#) [PMOF-9767NS-40DQ](#) [PMOF-6027NSN-36KDQ](#) [AOM-5024L-HD-R](#) [ROM-2235P-HD-R](#) [CMC-9745-130T](#) [BJ-28471-000](#) [POM-2730L-HD-R](#) [TOM-1537L-HD-R](#) [ROM-2235L-HD-R](#) [DUM-4546L-C3310-R](#) [CMC-4015-130T](#) [CMC-6050-40T](#) [CMC-6015-47P](#) [EM-4530](#) [EM-6022](#)