

SPECIFICATION FOR APPROVAL

承 認 書

Description : Piezo Audio Transducer

Kingstate Part No. : KMTG1612

Customer's Model No. : _____

Specification No. : PKD-9866

Number Of The Edition : 1.1

CUSTOMER'S APPROVED SIGNATURE		





志豐電子股份有限公司 KINGSTATE ELECTRONICS CORP.

Address: 10F, No. 69-11, Sec. 2, Chung Cheng E. Rd., Tamshui County, Taipei Hsien, Taiwan, R.O.C.

International sales dept.: TEL:886-2-2809-5651 FAX:886-2-2809-7151

Domestic sales dept.: TEL:886-2-2809-0668 FAX:886-2-28096748

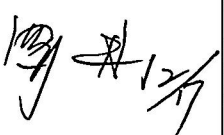
<http://www.kingstate.com.tw>

Approved by	Checked by	Issued by
		Yao 2023/02/17



A. SCOPE 範疇

This specification applies piezo audio transducer, **KMTG1612**

此規格書適用於壓電式蜂鳴器, **KMTG1612**

B. SPECIFICATION 規格

No.	Item	Unit	Specification	Condition
1	Operating Volt. Range 最大操作電壓	Vp-p	MAX 25	
2	Current consumption 消耗電流	mA	MAX 15	at 12Vp-p, square wave, 4.0KHz.
3	Sound pressure level 輸出音壓	dB	MIN 90	at 10cm/12Vp-p, square wave, 4.0KHz
4	Electrostatic capacity 靜電容量	pF	20,000 ± 30%	at 1KHz/1V
5	Operating temp. 操作溫度	°C	-40 ~ +120	
6	Storage temp. 儲存溫度	°C	-40 ~ +120	
7	Dimension 尺寸	mm	L16.0 x W16.0 x H2.6	See appearance drawing 請參照外觀尺寸圖
8	Weight (MAX) 重量	gram	0.96	
9	Material 材質		LCP (White) + PCB (FR4)	
10	Terminal 端子		SMD type (鍍化金/Plating Au:3~5um)	See appearance drawing 請參照外觀尺寸圖
11	Environmental Protection Regulation 環保法規		RoHS 2.0	
12	Moisture sensitive level 濕敏等級	Class	5	Less than or equal to 30C/60%RH, 48 hours of Floor life. 小於或等於 30°C/60%RH 48 小時車間壽命

C. APPEARANCE DRAWING 外觀尺寸圖

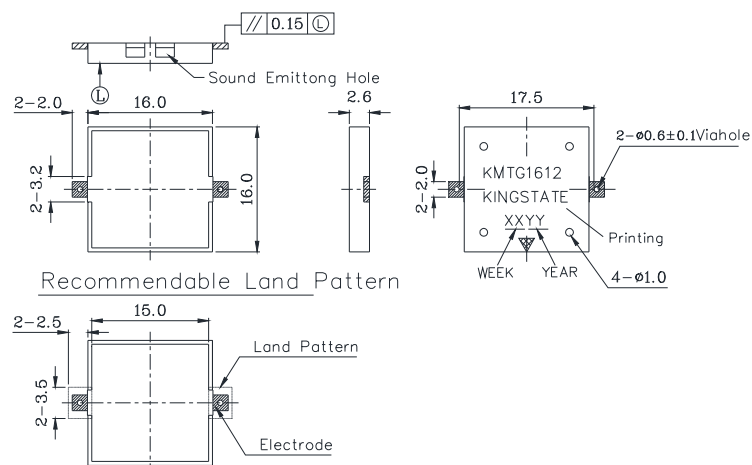

Tol: ± 0.2

Unit: mm

D. TYPICAL FREQUENCY RESPONSE CURVE 頻率響應曲線

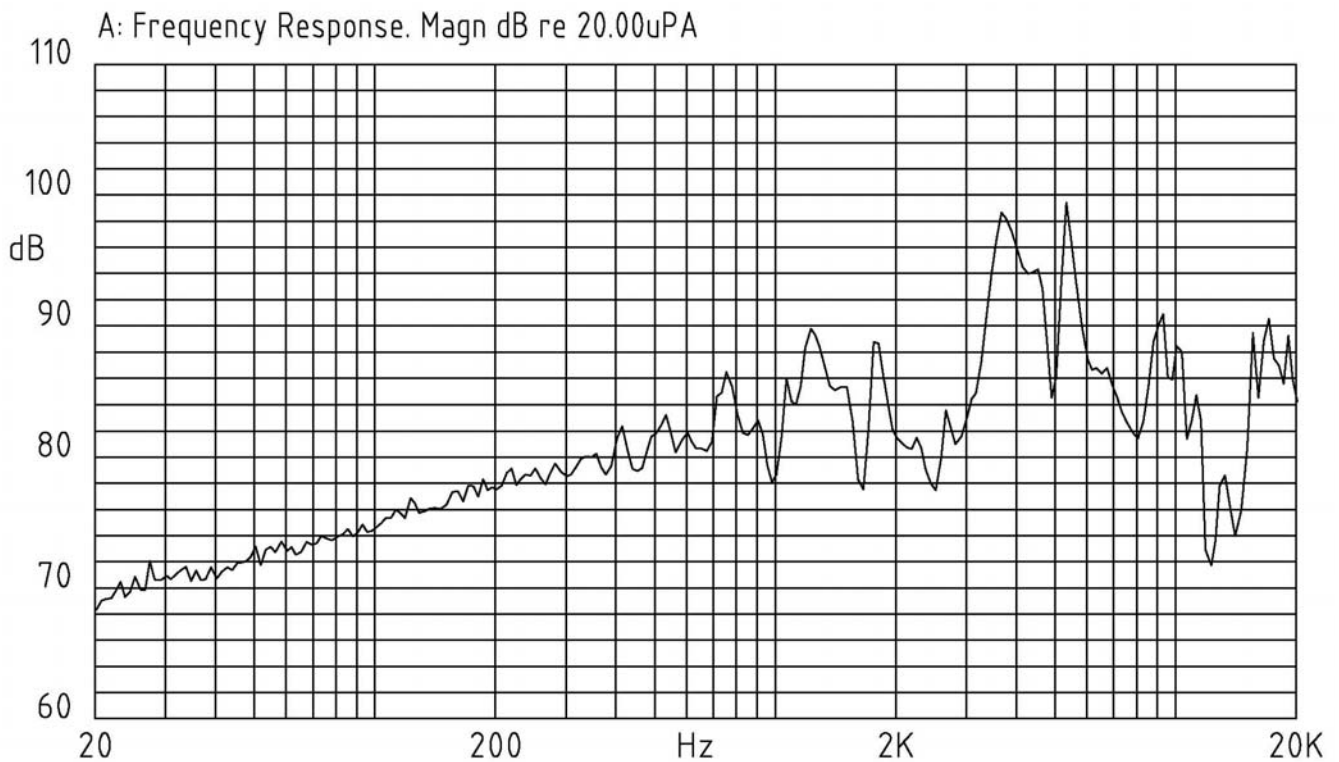

E. MEASURING METHOD 測量方法

S.P.L. Measuring Circuit 音壓測試接線圖

Input Signal: 12Vp-p, 4.0kHz, Square Wave

輸入信號: 12Vp-p, 4.0kHz, 方波

Temp.: 25±3°C Humidity: 60±10%, Free Room

溫度: 25±3°C, 濕度: 60±10%, Free Room

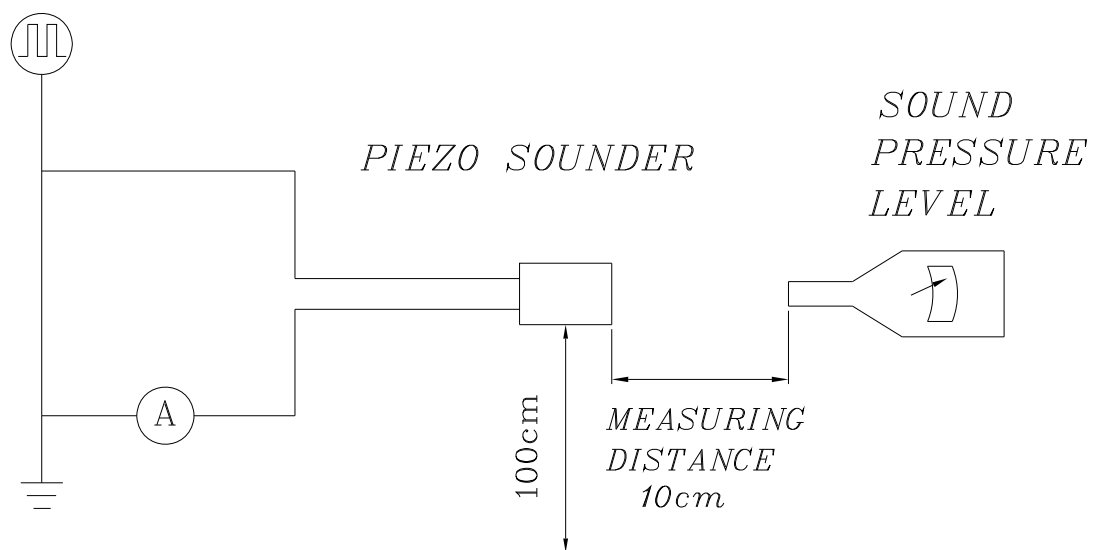

Mic : RION S.P.L meter UC30 or equivalent

Mic : RION 噪音計 UC30 或同等品

S.G : Hewlett Packard 33120A Function Generator or equivalent

S.G : Hewlett Packard 33120A 函數信號產生器或同等品

Test Photo:



F. MECHANICAL CHARACTERISTICS 機械特性

No.	Item	Test condition	Evaluation standard
1	Solderability 焊錫附著性	Lead terminals are immersed in rosin for 5 seconds and then immersed in solder bath of $+270 \pm 5^\circ\text{C}$ for 2 ± 0.5 second. 端子浸松香液中 5 秒後置於錫膏內,錫膏溫度: $+270\pm 5^\circ\text{C}$. 焊接時間: 2 ± 0.5 秒.	95% surface of lead pads must be covered with fresh solder 錫膏須覆蓋端子上方 95%
2	Soldering Heat Resistance 焊錫耐熱性	1)IR reflow 遠紅外線熱風迴焊爐 Pre-heating conditions shall be $+150$ to $+200^\circ\text{C}$ for 60 to 180 seconds. Ascending time up to $+250^\circ\text{C}$ shall be longer than 55 seconds. Heating conditions shall be within 15 seconds at $+245^\circ\text{C}$ min. But peak temperature shall be lower than $+250^\circ\text{C}$, then being place in natural condition for 1 hour, sounder shall be measured 預熱條件為加熱到 $+150$ to $+200^\circ\text{C}$ 為 60 到 180 秒. 加熱到 245°C 時間須長於 55 秒. 焊接條件為 15 秒最低 $+245^\circ\text{C}$, 最高不可超過 $+250^\circ\text{C}$. 結束後須靜置於室溫中 1 小時後進行檢測 2)Soldering Iron 烙鐵 Soldering iron of $+270\pm 5^\circ\text{C}$ shall be placed 0.5mm above from electrode of sounder. Melting solder through soldering iron shall be applied to electrode for 3 ± 1 seconds, then being place in natural condition for 4 hours, sounder shall be measured. $+270\pm 5^\circ\text{C}$ 的烙鐵置於電極上方 0.5mm 處, 以烙鐵將焊錫熔於電極上 3 ± 1 秒,然後置於室溫中 4 小時後進行檢測.	No interference in operation. 操作上無任何不良.
3	Terminal Mechanical Strength 端子強度	The force 10 seconds of 9.8N(1kg) is applied to each terminal is axial direction. 對每一端子以軸方向, 施 9.8N(1kg)拉力 10 秒.	No damage and cutting off 端子不鬆動, 不脫落
4	Vibration 振動測試	The part shall be subjected to a vibration cycle of 10Hz to 55Hz in a period of 1 minute. Total peak amplitude shall be 1.55mm . The vibration test shall consist of 2 hours per axis in each three axes (X, Y, Z), Total 6 hours. 振幅 1.55mm, 頻率 10Hz-55Hz,時間 1 分鐘. X,Y,Z 3 個方向各 2 小時, 共 6 小時.	After the test the part shall meet specifications without any damage in appearance and performance except SPL. The SPL shall be in $\pm 4\text{dB}$ compared with initial one, Higher than 81 dB. 經測試後,單體除音壓外,外觀及電氣特性須符合規格.輸出音壓變化量須在 $\pm 4\text{dB}$ 內,且 $>81\text{dB}$.
5	Piezo ass'y Solder joint rally test 蜂鳴片焊點拉力測試	Piezo ass'y on the spot for each piece of wire, to exert the level of tension, the rate of 20mm/min, may have to bear the min.200g Rally 對蜂鳴片每一焊點的線材,施加水平拉力,速率 20mm/min,須可承受 min.200g 的拉力	The product which was tested can not be packed and deliver, it should be abandoned 測試后的產品不可包裝出貨,以報廢處理

G. Recommended Temperature Profile For Reflow Oven 建議迴焊爐溫度曲線

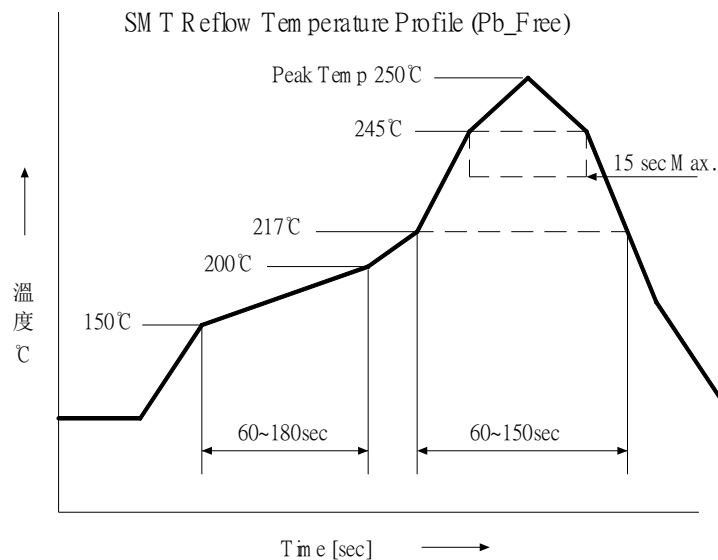

Note: 245°C is Less than 15 sec., but only pass the lead free reflow once. The SPL should be in ± 4 dB compared with initial one, Higher than 81 dB.

備注: 245°C不可超過 15 秒, 且只能過無鉛迴流焊一次。輸出音壓變化量須在 ± 4 dB 內, 且 >81 dB.

H. ENVIRONMENT TEST 環境測試

No.	Item	Test Condition	Evaluation standard
1	High temp. test 高溫測試	After being placed in a chamber at +120°C for 240 hours 置於+120°C環境中 240 小時	
2	Low temp. test 低溫測試	After being placed in a chamber at -40°C for 240 hours 置於-40°C環境中 240 小時	
3	Humidity test 相對濕度測試	After being placed in a chamber at +40°C and 90 \pm 5% relative humidity for 240 hours 置於+40°C, 相對濕度 90 \pm 5% 環境中 240 小時	
3	Temp. Cycle 溫度循環測試	The part shall be subjected to 5 cycles. 單體承受溫度循環測試 5 次, 其循環內容如圖示。 Unit: M inute	Being placed for 4 hours at +25 °C , buzzer shall be measured. The value of oscillation frequency/ current consumption should be in $\pm 10\%$ compared with initial ones .The SPL should be in ± 4 dB compared with initial one, Higher than 81 dB. 經測試後, 靜置於+25°C (室溫) 環境中 4 小時後, 諧振頻率與消耗電流變化量須在 $\pm 10\%$ 內。輸出音壓變化量須在 ± 4 dB 內, 且 >81 dB.

I. RELIABILITY TEST 信賴性測試

No.	Item	Test condition	Evaluation standard
1	Operating life test 壽命測試	<p>1. Continuous life test 高溫壽命測試(連續) 48 hours continuous operation at +105°C with rated voltage applied. 在+105°C環境下,以額定電壓連續操作 48 小時.</p> <p>2. Intermittent life test 室溫壽命測試(間歇) A duty cycle of 1 minute on, 1 minutes off, a minimum of 5000 times at room temp.(+25 ±2°C)and rated voltage applied. 在室溫下(+25 ±2°C), 以額定電壓操作, 通電 1 分鐘/斷電 1 分鐘,測試 5000 次循環.</p>	<p>Being placed for 4 hours at +25 °C , buzzer shall be measured. The value of oscillation frequency/ current consumption should be in ±10% compared with initial ones .The SPL should be in ±4dB compared with initial one, Higher than 81 dB.</p> <p>經測試後, 靜置於+25°C (室溫) 環境中 4 小時後,諧振頻率與消耗電流變化量須在±10%內. 輸出音壓變化量須在±4dB 內,</p>

TEST CONDITION.

Standard Test Condition 一般測試條件	:	a) Temperature : +5 ~ +35°C	b) Humidity : 45-85%	c) Pressure : 860-1060mbar
Judgment Test Condition 爭議時測試條件	:	a) 溫度 : +5 ~ +35°C	b) 濕度 : 45-85%	c) 氣壓 : 860-1060mbar
	:	a) Temperature : +25 ± 2°C	b) Humidity : 60-70%	c) Pressure : 860-1060mbar
	:	a) 溫度 : +25 ± 2°C	b) 濕度 : 60-70%	c) 氣壓 : 860-1060mbar

J. APPEARANCE

外觀

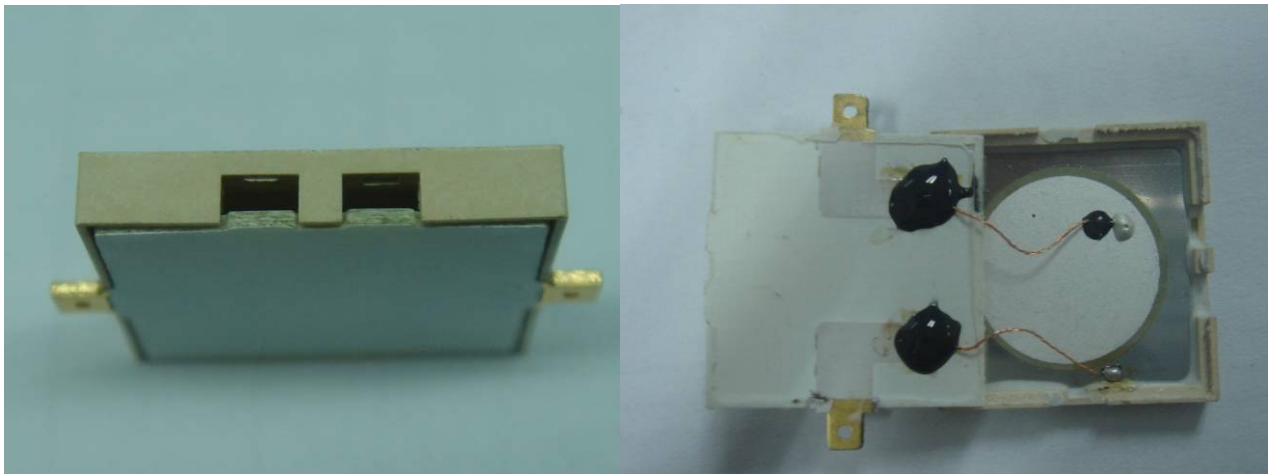

K. ADHEREING METHOD FOR CERAMIC DISC & NI-ALLOY DISC

陶瓷片與鎳合金片粘接方式



L. PIN assembly Resin test standard PIN 組裝溢膠檢驗標準

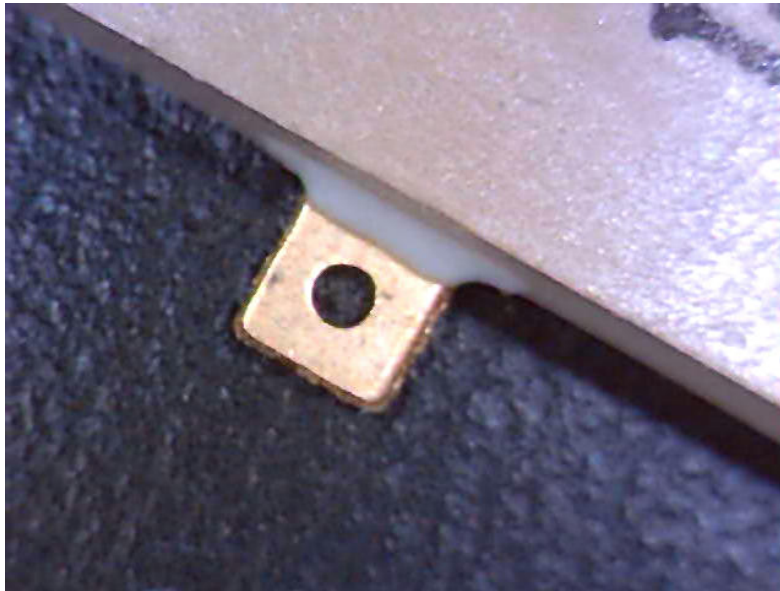

PIN bottom are not allowed to overflow glue, glue over the top criteria: Max.0.25mm

PIN 底面不允許有溢膠,上面溢膠標準:Max.0.25mm

M. PACKING STANDARD 包裝規格

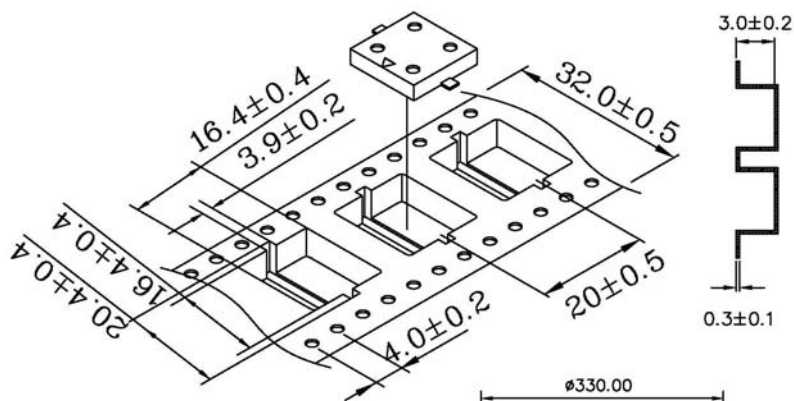

防潮卡位置

Packing requirements:
包裝要求:

1. Apply drying treatment before packing the product
产品装袋前干燥处理
2. Vacuum package
真空包装
3. Add desiccant
加入去湿剂
4. Add moisture indication card
加入防潮標示卡

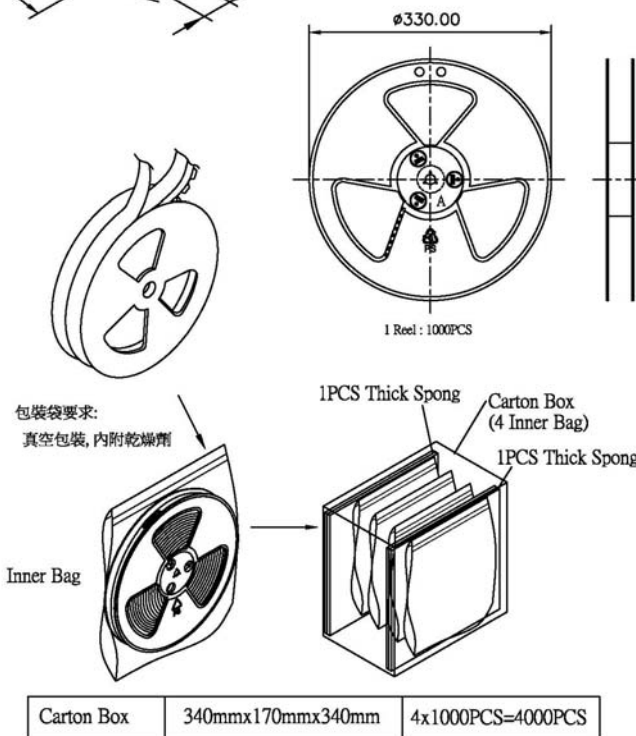

產品使用說明

1. 此產品在小于或等于 30°C/60%RH 環境下 48 小時車間壽命.
2. 此產品開包裝后在 48 小時以內未使用完的可重新換包裝抽真空保存.

外箱需貼此標籤

X-ON Electronics

Largest Supplier of Electrical and Electronic Components

Click to view similar products for [Piezo Buzzers & Audio Indicators](#) category:

Click to view products by [Kingstate](#) manufacturer:

Other Similar products are found below :

[6-4 ESZ-26B F/BC 40P-DR LF](#) [FDG06PSLLF](#) [FDG111PLF](#) [F/DGX12P WITH LABEL LF](#) [F/NRMB 24 BLACK LF](#) [PF-35N29WQ](#) [PFD-21A29W](#) [PFD-27A35PQ](#) [PL-21N30WQ](#) [PLD-21N30W](#) [PLD-21N30WQ](#) [PS-531Q](#) [PT-3534FP](#) [B822B](#) [B/CP28/100DB/BLACK LF](#) [S6109](#) [SC110E](#) [SC2036ACP](#) [SC616N-2](#) [SC628FW](#) [SC628MPG](#) [SC648D](#) [SCS045MD9DT3S](#) [ESZ-25B-5-250B](#) [FCM12PLF](#) [F/EB20P-DR LF](#) [AI-4228-TF-LW305-R](#) [FSMD8585JSLF](#) [F/SU 21-02 LF](#) [F/TCW 05 WITH LABEL LF](#) [F/TCW 12 WITH LABEL LF](#) [F/UCW 03 WITH LABEL LF](#) [PFD-27N36W](#) [PKM35-4A0](#) [PL-35N29WQ](#) [PLD-27A35PQ](#) [PS-552Q](#) [REF-202](#) [KBS-20DA-7AS](#) [KBS-27DA-5C-105](#) [LSC628ANR](#) [PL-21N31PQ](#) [F/DGX 05P WITH LABEL LF](#) [MSR516NP](#) [STA22702W](#) [STA20502](#) [SBM616J](#) [SBM616P](#)