

# SPECIFICATION FOR APPROVAL

## 承 認 書

Description : Piezo Audio Transducer

Kingstate Part No. : KMTG1740D

Customer's Model No. : \_\_\_\_\_

Specification No. : POD-5668

Number Of The Edition : 1.1

CUSTOMER'S APPROVED SIGNATURE		

 志豐電子股份有限公司 KINGSTATE ELECTRONICS CORP.

Address : 10F, No. 69-11, Sec. 2, Chung Cheng E. Rd., Tamshui County, Taipei Hsien, Taiwan, R.O.C.

International sales dept.: TEL:886-2-2809-5651 FAX:886-2-2809-7151

Domestic sales dept.: TEL:886-2-2809-0668 FAX:886-2-28096748

<http://www.kingstate.com.tw>

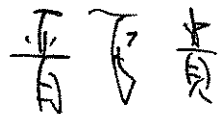
Approved by	Checked by	Issued by
 2020.03.12	陈中煌 2020/3/12	Huangjie 2020/03/12

## A. SCOPE 範疇

This specification applies piezo audio transducer, **KMTG1740D**

此規格書適用於壓電式蜂鳴器, **KMTG1740D**

## B. SPECIFICATION 規格

No.	Item	Unit	Specification	Condition
1	Max input Voltage 最大操作電壓	Vp-p	MAX 30	
2	Current consumption 消耗電流	mA	MAX 12	at 12Vp-p, square wave, 4.0KHz.
3	Sound pressure level 輸出音壓	dB	Min 90	at 10cm/12Vp-p, square wave, 4.0KHz
4	Electrostatic capacity 靜電容量	pF	16,000 ± 30%	at 100Hz/1V
5	Operating temp. 操作溫度	°C	-40 ~ +85	
6	Storage temp. 儲存溫度	°C	-40~ +90	
7	Dimension 尺寸	mm	φ 17.0 x H6.2	See appearance drawing 請參照外觀尺寸圖
8	Weight (MAX) 重量	gram	2.0	
9	Material 材質		PPS (Black)	
10	Terminal 端子		SMD type (鍍全錫/Plating Sn)	See appearance drawing 請參照外觀尺寸圖
11	Environmental Protection Regulation 環保法規		RoHS2.0	Piezo electronic devices and high melting temperature type solders are exempted from RoHS 2.0 Lead contain restriction. 壓電陶瓷片產品和高熔點類型焊料含鉛是 RoHS 2.0 豁免的
12	Storage life 保存期限	month	6	6 months preservation at room temp.(25±3°C), Humidity40% 在室溫下 25±3°C, 濕度 40% 以下可保存 6 個月.
13	MSL 濕敏指數		2a	≤30°C/60%RH 672H Floor life 小於或等於 30°C/60%RH 672 小時車間壽命

## C. APPEARANCE DRAWING 外觀尺寸圖

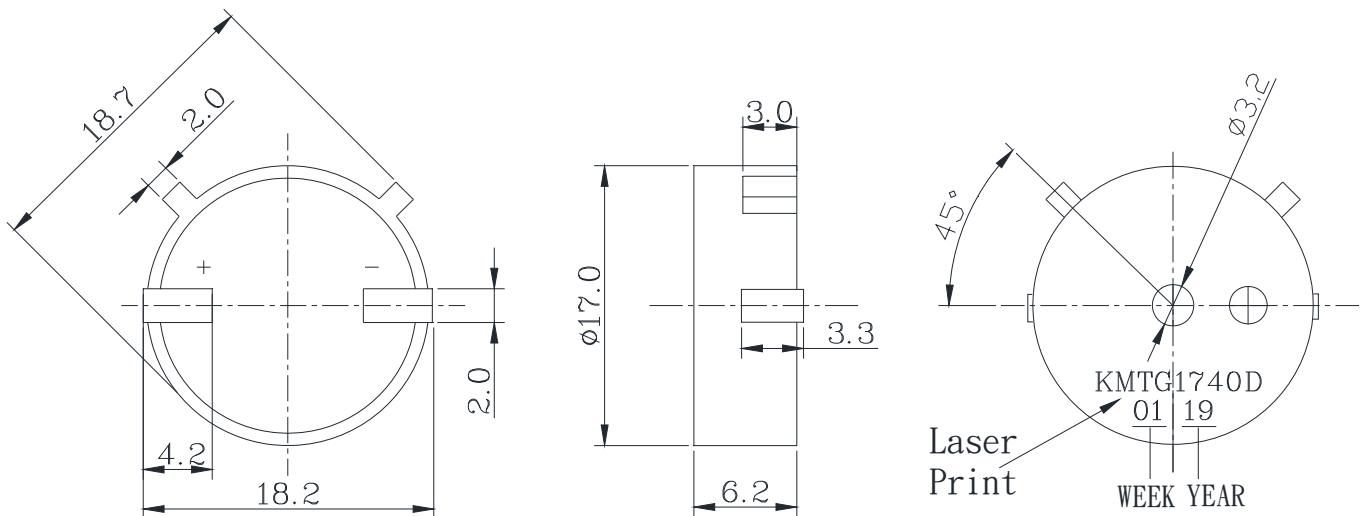

**Tol : ± 0.5**  
**Unit : mm**

## D. MEASURING METHOD 測量方法

S.P.L. Measuring Circuit 音壓測試接線圖

Input Signal: 12Vp-p, 4.0kHz, Square Wave

輸入信號: 12Vp-p, 4.0kHz, 方波

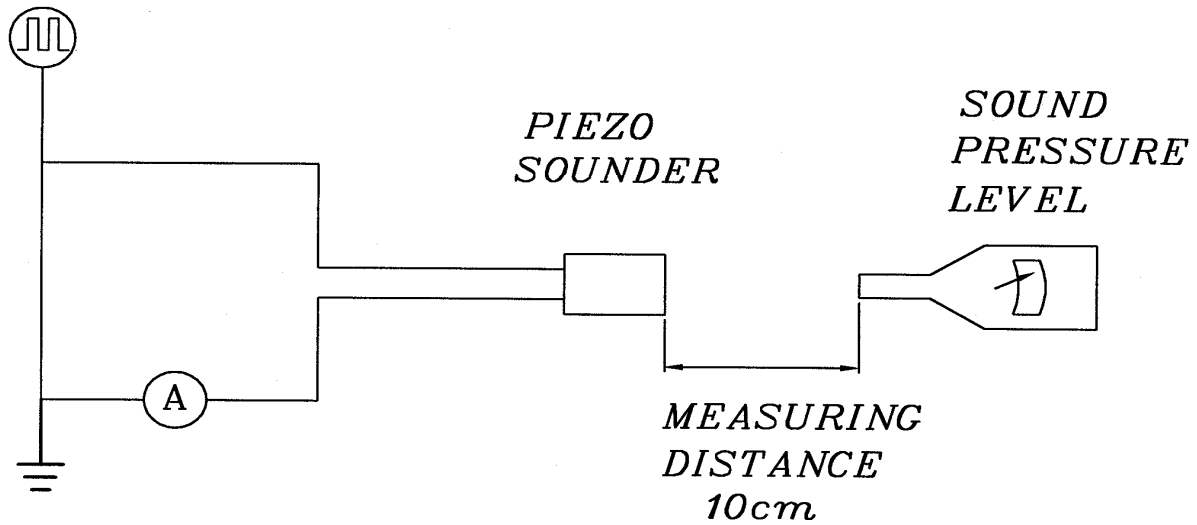

Mic : RION S.P.L meter UC30 or equivalent

Mic : RION 噪音計 UC30 或同等品

S.G : Hewlett Packard 33120A Function Generator or equivalent

S.G : Hewlett Packard 33120A 函數信號產生器或同等品

## E. TYPICAL FREQUENCY RESPONSE CURVE 頻率響應曲線

For Reference Only 僅供參考

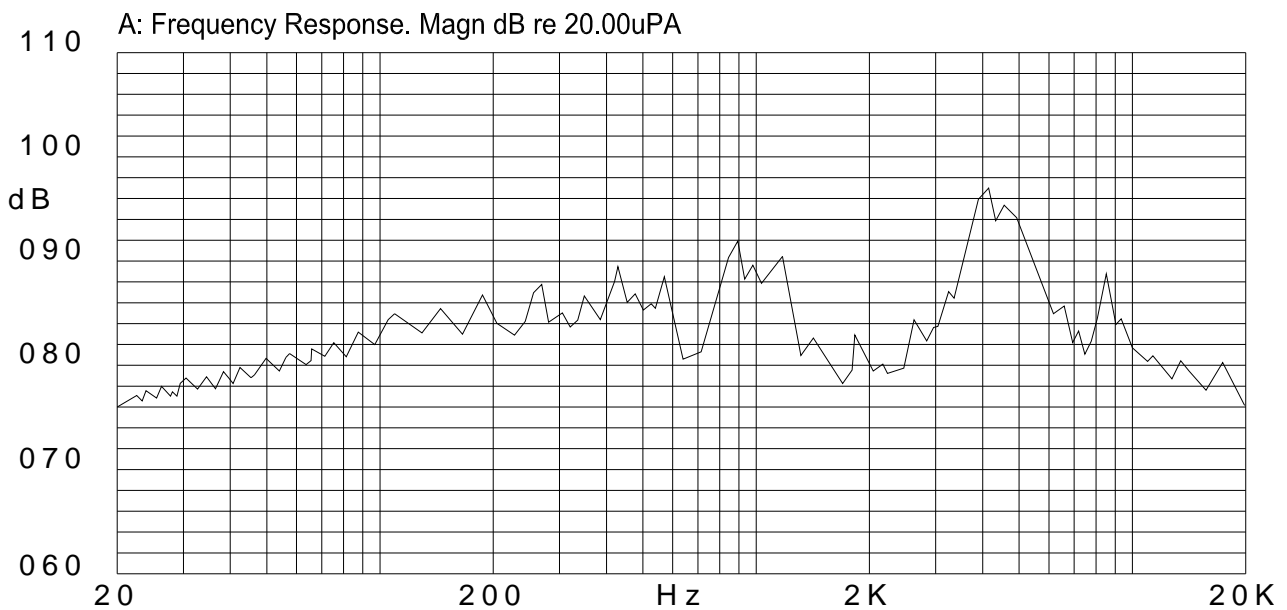

## F. MECHANICAL CHARACTERISTICS 機械特性

No.	Item	Test Condition	Evaluation standard
1	Solderability 焊錫附著性	Lead terminals are immersed in rosin for 5 seconds and then immersed in solder bath of $+270\pm 5^{\circ}\text{C}$ for $3\pm 1$ seconds. 端子部份浸入松香溶液 5 秒後,再浸入 $+270\pm 5^{\circ}\text{C}$ 熔融焊錫槽中 $3\pm 1$ 秒.	90% min. lead terminals shall be wet with solder. (Except the edge of terminal) 浸入端子部份附著焊錫 90% 以上.(末端斷面不算)
2	Soldering Heat Resistance 焊錫耐熱性	Lead terminal are immersed up to 1.5mm from sounder's body in solder bath of $+300\pm 5^{\circ}\text{C}$ for $3\pm 0.5$ seconds or $+260\pm 5^{\circ}\text{C}$ for $10\pm 1$ seconds. 距離端子根部 1.5mm 的位置,浸入 $+300\pm 5^{\circ}\text{C}$ 的焊錫槽 $3\pm 0.5$ 秒,或 $+260\pm 5^{\circ}\text{C}$ 的焊錫槽 $10\pm 1$ 秒.	No interference in operation 操作無任何不良.
3	Vibration 振動試驗	Buzzer shall be measured after being applied vibration of amplitude of 1.5mm with 10 to 55hz band of vibration frequency to each of 3 per-pendicular directions for 2 hours. 振動週波數 10~55HZ、全振幅 1.5mm 於 X.Y.Z 3 個方向,各 2 小時.	The value of oscillation frequency/ current consumption should be in 10% compared with initial ones. The SPL should be in $\pm 10\text{dB}$ compared with initial one.
4	Drop test 落下測試	The part only shall be dropped from a height of 70cm onto a 10mm thick wooden board 3 times in 3 axes (X.Y.Z). (a total of 9 times). 單體從 70 公分高處, X.Y.Z.3 個方向,各 3 回,落於 10mm 厚木板上.	諧振頻率與消耗電流變化量須在 $\pm 10\%$ 內. 輸出音壓變化量須在 $\pm 10\text{dB}$ 內.

## G. ENVIRONMENT TEST 環境測試

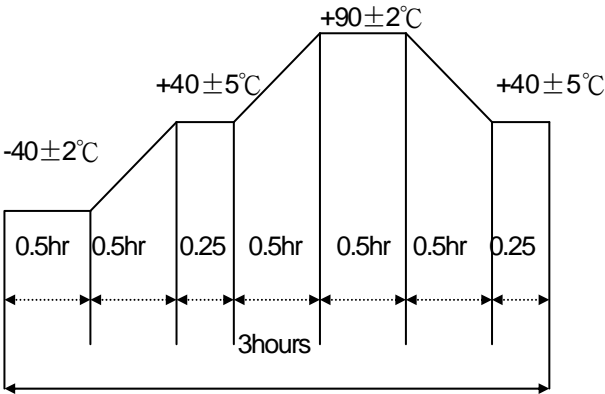
No.	Item	Test Condition	Evaluation standard
1	High temp. test 高溫測試	After being placed in a chamber at $+90^{\circ}\text{C}$ for 120 hours 置於 $+90^{\circ}\text{C}$ 環境中 120 小時	Being placed for 4 hours at $+25^{\circ}\text{C}$ , buzzer shall be measured. The value of oscillation frequency/ current consumption should be in $\pm 10\%$ compared with initial ones. The SPL should be in $\pm 10\text{dB}$ compared with initial one. 經測試後, 靜置於 $+25^{\circ}\text{C}$ (室溫) 環境中 4 小時後, 諧振頻率與消耗電流變化量須在 $\pm 10\%$ 內. 輸出音壓變化量須在 $\pm 10\text{dB}$ 內.
2	Low temp. test 低溫測試	After being placed in a chamber with $-40^{\circ}\text{C}$ for 120 hours 置於 $-40^{\circ}\text{C}$ 環境中 120 小時	
3	Humidity test 相對濕度測試	After being placed in a chamber at $+40^{\circ}\text{C}\pm 2^{\circ}\text{C}$ and 90~95% relative humidity for 120 hours 置於 $+40^{\circ}\text{C}\pm 2^{\circ}\text{C}$ , 相對濕度 90~95% 環境中 120 小時	
4	Temp. cycle test 溫度循環試驗	The part shall be subjected to 5 cycles. One cycle shall be consist of : 單體承受溫度循環測試 5 次,其循環內容如圖示: 	

## H. RELIABILITY TEST 信賴性測試

No.	Item	Test condition	Evaluation standard
1	Operating life test 壽命測試	<p>1. Continuous life test 高溫壽命測試(連續) 48 hours continuous operation at +70°C with rated voltage applied. 在+70°C環境下,以額定電壓連續操作 48 小時.</p> <p>2. Intermittent life test 室溫壽命測試(間歇) A duty cycle of 1 minute on, 1 minutes off, a minimum of 5000 times at room temp.(+25±2°C) and rated voltage applied. 在室溫下(+25±2°C), 以額定電壓操作, 通電 1 分鐘/斷電 1 分鐘, 測試 5000 次循環.</p>	<p>Being placed for 4 hours at +25°C, buzzer shall be measured. The value of oscillation frequency/ current consumption should be in ±10% compared with initial ones. The SPL should be in ±10dB compared with initial one.</p> <p>經測試後, 靜置於+25°C (室溫) 環境中 4 小時後, 諧振頻率與消耗電流變化量須在±10%內. 輸出音壓變化量須在±10dB 內.</p>

### TEST CONDITION.

Standard Test Condition	:	a) Temperature : +5 ~ +35°C	b) Humidity : 45-85%	c) Pressure : 860-1060mbar
一般測試條件	:	a) 溫度 : +5 ~ +35°C	b) 濕度 : 45-85%	c) 氣壓 : 860-1060mbar
Judgement Test Condition	:	a) Temperature : +25 ± 2°C	b) Humidity : 60-70%	c) Pressure : 860-1060mbar
爭議時測試條件	:	a) 溫度 : +25 ± 2°C	b) 濕度 : 60-70%	c) 氣壓 : 860-1060mbar

## I. Recommended Temperature Profile for Reflow Oven 推薦迴流焊曲線

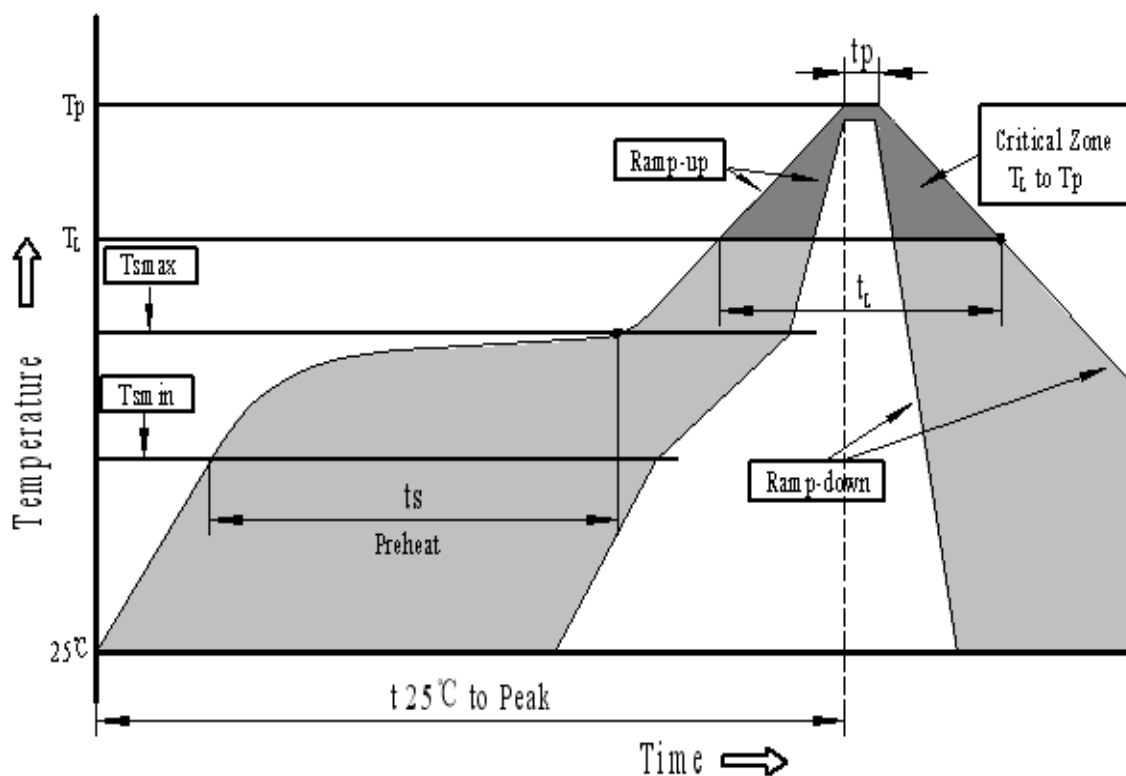

Profile Feature	Assembly
Average ramp-up rate( $T_L$ to $T_p$ )	3°C/second max.
Preheat	
-Temperature Min.( $T_{s_{min}}$ )	150°C
-Temperature Min.( $T_{s_{max}}$ )	200°C
-Temperature Min.(ts)	60~180 seconds
$T_{s_{max}}$ to $T_L$	
-Ramp-up Rate	3°C/second max.
Time maintained above:	
- Temperature( $T_L$ )	217°C
-Time( $T_L$ )	60~150 seconds
Peak temperature( $T_p$ )	245°C+0/-5
Time within 5°C of actual Peak temperature (tp)	6 seconds max.
Ramp-down Rate	6°C/second max.
Time 25°C to Peak Temperature	8 minutes max.
<b>We suggest the customer do the reflow soldering once.</b>	

According to the standard : IPC/JEDEC J-STD-020C

\*Reflow can't over 1 time. 迴流焊次數不超過 1 次.

## J. Recommended land pattern 建議基板設計尺寸圖

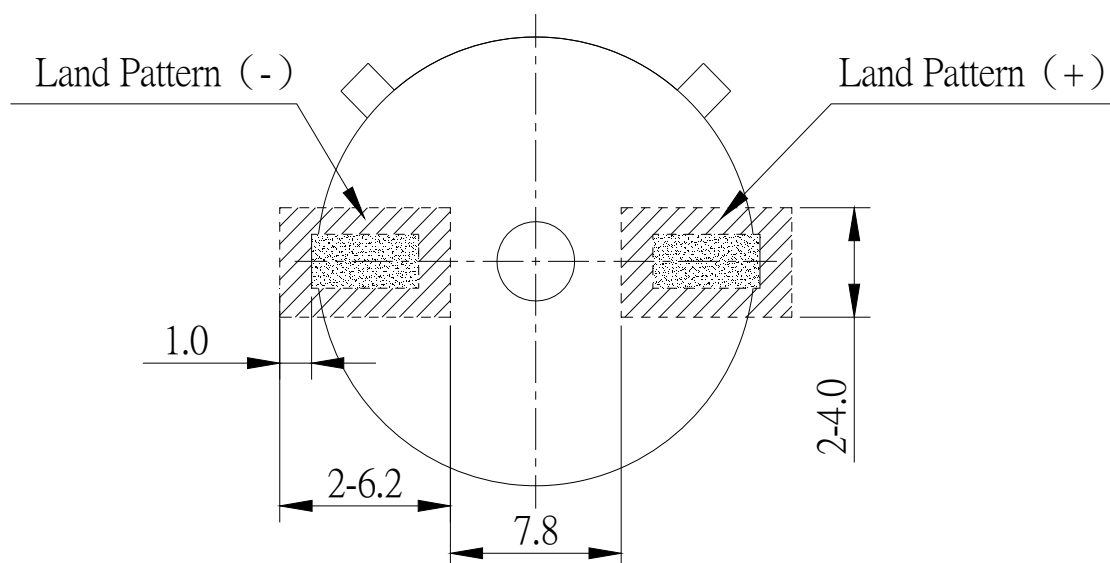

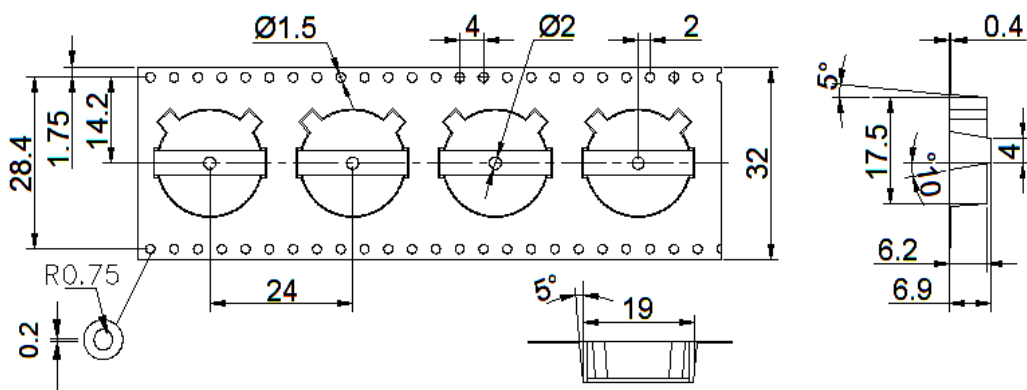

# K. PACKING STANDARD 包裝規格

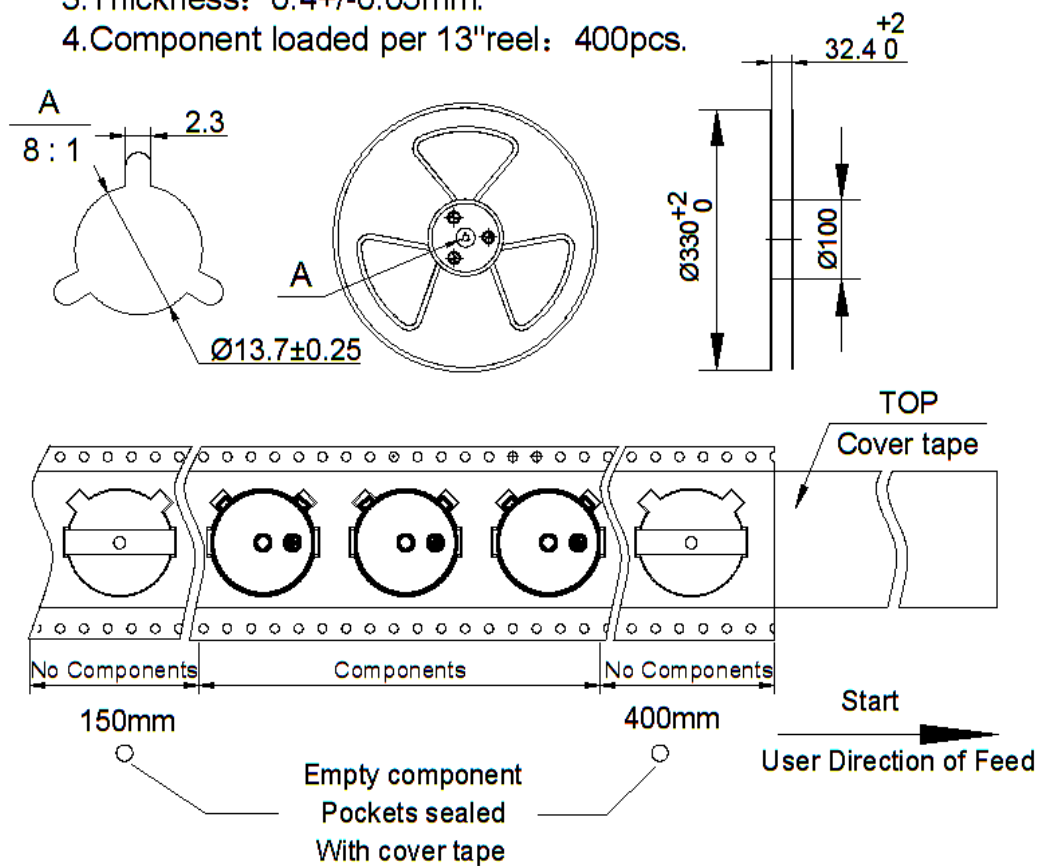

## NOTE:

- 1.10 sprocket hole pitch cumulative tolerance +/-0.2mm.
- 2.All dimensions meet EIA-481-D requirements.
- 3.Thickness: 0.4+/-0.05mm.
- 4.Component loaded per 13" reel: 400pcs.



Lot No.	XXXXXXXXXX
Part No.	XXXXXXXXXX
Quantity	XXXX PCS
Date:	DD MM YY
	
	

\* The label stucked on inner boxes and the outer of carton.



真空包裝袋 / 內附乾燥劑  
HIC 卡 / MSD 標貼/標籤  
符合MSL-2a

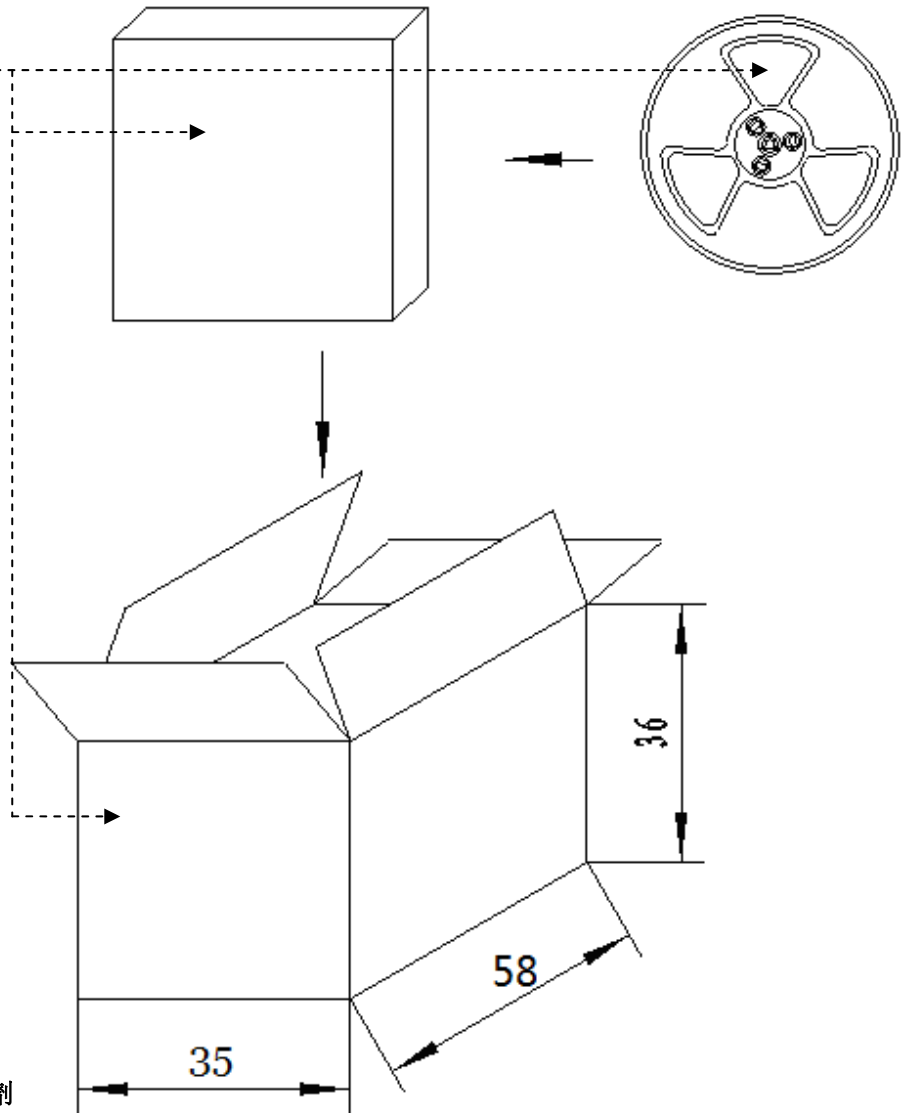
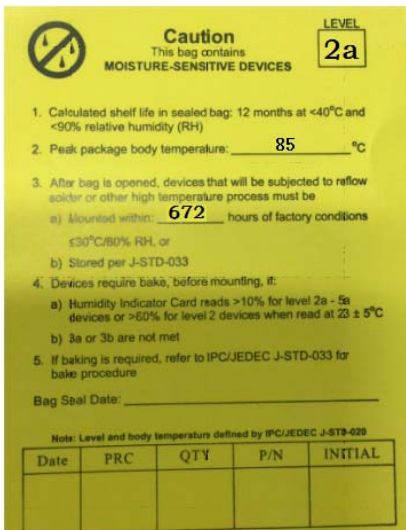

Inner Box	330mmx330mmx30mm	1x400PCS=400PCS
Carton Box	350mmx580mmx360mm	10x400PCS=4,000PCS



## Notice:

1) **The products must not be washed.**

2) **Storage Condition:**

The products should be stored in the room, where the temperature/humidity is stable.

And avoid such places where there are large temperature changes.

Recommended storage products under the following conditions:

Temperature: -10 to +40°C Humidity: 15 to 85% R.H.

3) **Expire Date on Storage:**

Expire date (shelf life) of the products is **six months** after delivered under the conditions of a sealed and an unopened package.

Please use the products with **six months** after delivered.

4) **Notice on product Storage:**

Please use the products immediately after the package is opened, because the characteristics may be reduced at quality.

## X-ON Electronics

Largest Supplier of Electrical and Electronic Components

*Click to view similar products for [Piezo Buzzers & Audio Indicators](#) category:*

*Click to view products by [Kingstate](#) manufacturer:*

Other Similar products are found below :

[6-4 ESZ-26B F/BC 40P-DR LF](#) [FDG06PSLLF](#) [FDG111PLF](#) [F/DGX12P WITH LABEL LF](#) [F/NRMB 24 BLACK LF](#) [PF-35N29WQ](#) [PFD-21A29W](#) [PFD-27A35PQ](#) [PL-21N30WQ](#) [PLD-21N30W](#) [PLD-21N30WQ](#) [PS-531Q](#) [PT-3534FP](#) [B822B](#) [B/CP28/100DB/BLACK LF](#) [S6109](#) [SC110E](#) [SC2036ACP](#) [SC616N-2](#) [SC628FW](#) [SC628MPG](#) [SC648D](#) [SCS045MD9DT3S](#) [ESZ-25B-5-250B](#) [FCM12PLF](#) [F/EB20P-DR LF](#) [AI-4228-TF-LW305-R](#) [FSMD8585JSLF](#) [F/SU 21-02 LF](#) [F/TCW 05 WITH LABEL LF](#) [F/TCW 12 WITH LABEL LF](#) [F/UCW 03 WITH LABEL LF](#) [PFD-27N36W](#) [PKM35-4A0](#) [PL-35N29WQ](#) [PLD-27A35PQ](#) [PS-552Q](#) [REF-202](#) [KBS-20DA-7AS](#) [KBS-27DA-5C-105](#) [LSC628ANR](#) [PL-21N31PQ](#) [F/DGX 05P WITH LABEL LF](#) [MSR516NP](#) [STA22702W](#) [STA20502](#) [SBM616J](#) [SBM616P](#)