

KAS-33100-002
"Walleye" Microphone
Evaluation Kit

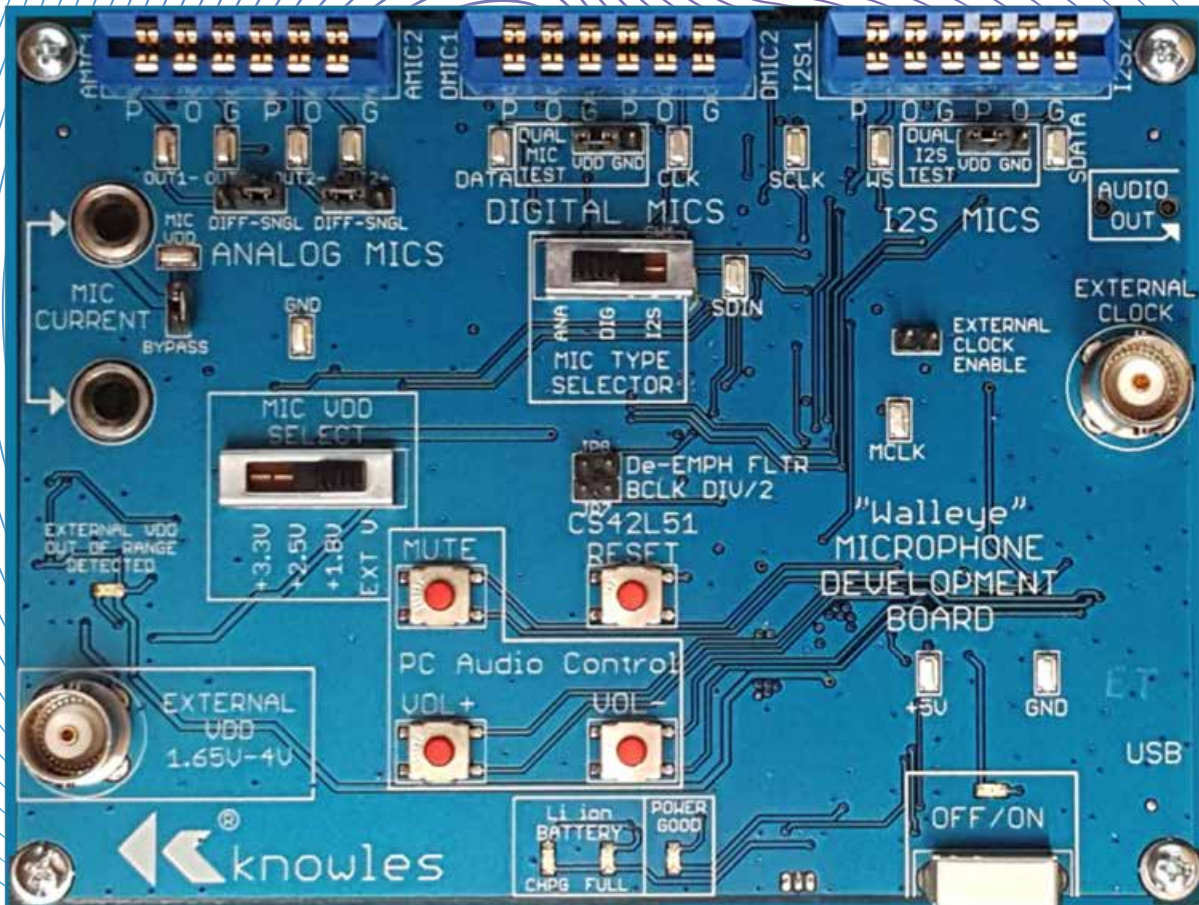

KAS-33100-002

Kit Description

The KAS-33100-002 Walleye microphone evaluation kit allows for simple and easy evaluation of SiSonic™ MEMS microphones. This evaluation system can be used to evaluate up to 2 channels of audio for multiple MEMS microphone types. Microphone types include single ended and differential Analog MEMS microphones, Digital PDM MEMS microphones, and I2S MEMS microphones.

Walleye Evaluation Board

The intended use is for the evaluation and test of the Knowles Electronics line of MEMS microphones.

The board is designed to support R&D activities, and is not intended for qualification or production test use.

The Walleye board provides the interface circuitry for 1 or 2 analog, 1 or 2 digital, or 1 or 2 I2S digital microphones.

Note: The Walleye board can pass mono or stereo audio of the same microphone types (i.e. 2 digital PDM mics). The Walleye board cannot pass audio of mixed types simultaneously.

Kit Contents

- **AAS-SM-WALLEYE Microphone Evaluation Board Assembly.**
- **USB A type to Mini B type cable.**
- **Flex Adapter PCB's part# KCB2734-C (3 Total).**
- **SPH1668LM4H/Hampton (bottom port PDM) on Flex (2 Total).**
- **SPK0838HT4H/Barnes (top port PDM) on Flex (2 Total).**
- **SPH1642HT5H/Hardy V2 (top port analog) on Flex (2 Total).**
- **SPH0611LR5H/McIlrath (bottom port analog).**
- **SPH0645HM4H/Crawford (bottom port I2S) on flex (2 Total).**

KAS-33100-002

Fig 3

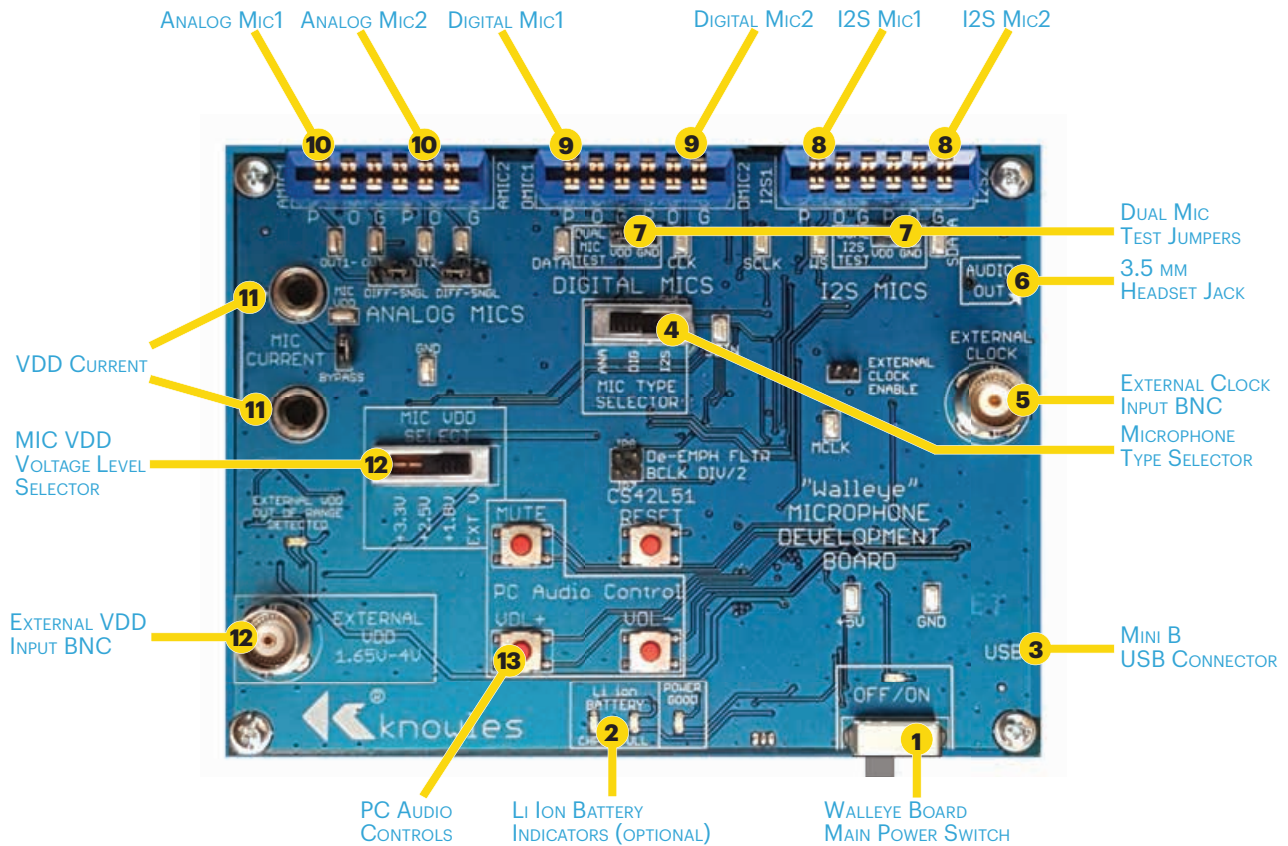

Functional Descriptions

1. Walleye Board Main Power Switch

Slide switch. When placed in the ON position will enable the internal voltage regulators and support circuitry. If all internal supplies power up correctly the POWER GOOD LED will turn on.

2. Li ion Battery (Optional)

Note: If optional 3.7V polymer lithium battery is installed the Li ion Battery will be charging when the USB cable is connected regardless of the Main Power switch position. This will be indicated through the CHRGE LED. When charging is complete the FULL LED will light. Battery charging is limited to 100mA of current from the connected PC. A full battery charge cycle can last up to 8 hours.

The Walleye board when running from a full battery should have enough power to allow operation for approximately 6-8 hours.

The battery can be found at Batteryspace.com Part# 043144 / IPOD-3G37V500. And additionally, a 330 ohm 0603 resistor should be placed at R12 and R13. The battery can be attached to the back of the PCB using 2 sided tape.



Walleye Microphone Evaluation Kit

Functional Descriptions (cont'd)

3. **USB Connector**
Main power input.
USB audio connection to PC(refer to PC audio driver section).
4. **Microphone Selector Type**
Slide switch to select microphone type.
5. **External Clock Input**
BNC connector. Center pin = clock signal input.
Signal type = square wave.
Minimum voltage level = 1.7Vpp.
Signal frequency range = 512KHz to 12.288MHz.
6. **3.5mm Headset Jack**
Headset jack connection or analog audio output from Walleye board codec.
7. **Dual Mic Test Jumper**
When set to VDD will source VDD to second mic.
When set to GND will remove VDD from second mic.
Feature used to test stereo mic configurations. With jumper set to VDD both mics will be powered. Remove the jumper or set jumper to GND and verify continued operation to Mic1.
8. **I2S Digital Mic Connector**
The connector can accommodate 2 coupons. Orientate microphone coupon to align the "P O G" markings on coupon with the "P O G" markings on the Walleye board.
9. **Digital Mic Connector**
The connector can accommodate 2 coupons. Orientate microphone coupon to align the "P O G" markings on coupon with the "P O G" markings on the Walleye board.
10. **Analog Mic Connector**
The connector can accommodate 2 coupons. Orientate microphone coupon to align the "P O G" markings on coupon with the "P O G" markings on the Walleye board.
11. **VDD Current Jacks**
Banana jack compatible, for measuring current using an external current meter. Note: remove jumper labeled Bypass to enable.
12. **Mic VDD Voltage Level Selector**
Select VDD voltage for microphones. Slide switch has 4 positions, 3.3V, 2.5V, 1.8V, and an external setting. The external setting allows for an external voltage source to be connected to the External VDD BNC.
13. **External VDD BNC Input**
External VDD voltage source connection through a BNC cable. (BNC center pin is VDD, shell is ground). Note: MIC VDD Selector switch needs to be set to EXT V.
14. **PC Audio Controls**
When the audio is routed through the USB connector to a PC these buttons can adjust the PC volume up or down. The Mute button will mute the PC audio.

KAS-33100-002

Flex Adapter Setup

Note the flex adapter board open and closed state below.

FIG 4

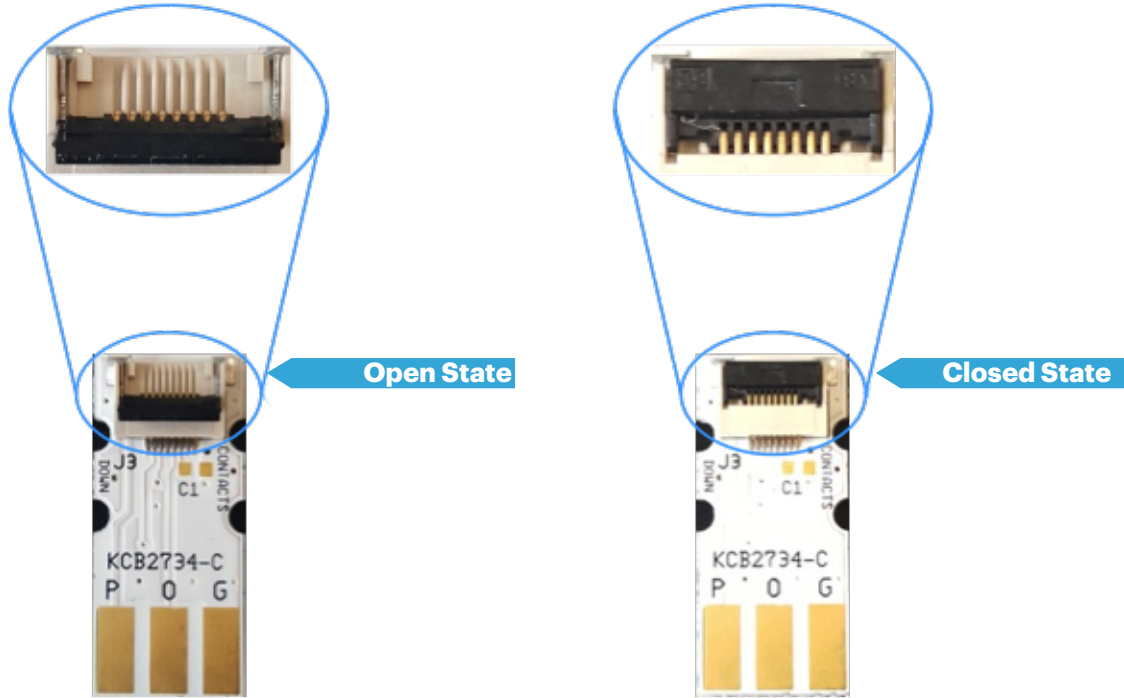

Note the flex adapter board's correct insertion orientation

FIG 5

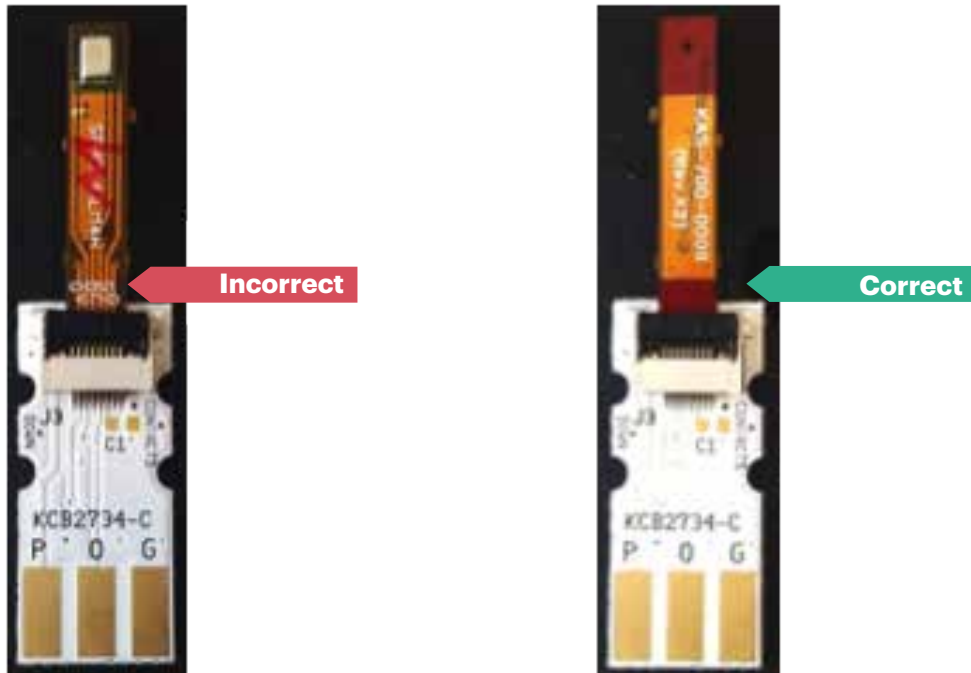

Note: Flex PCB traces should NOT be visible.

Walleye Microphone Evaluation Kit

USB Audio Path Setup

The Walleye board uses a Stereo Audio Codec with USB Interface. The USB controller uses standard Windows USB audio drivers.

To verify the USB audio path is functioning connect USB cable from Walleye board to PC. Slide Walleye board power switch to On. From the PC, open Control Panel → Hardware and Sound → Sound.

Click on the Recording tab and verify the USB audio codec appears.

The bar graph on the right will indicate audio detection.

FIG 6

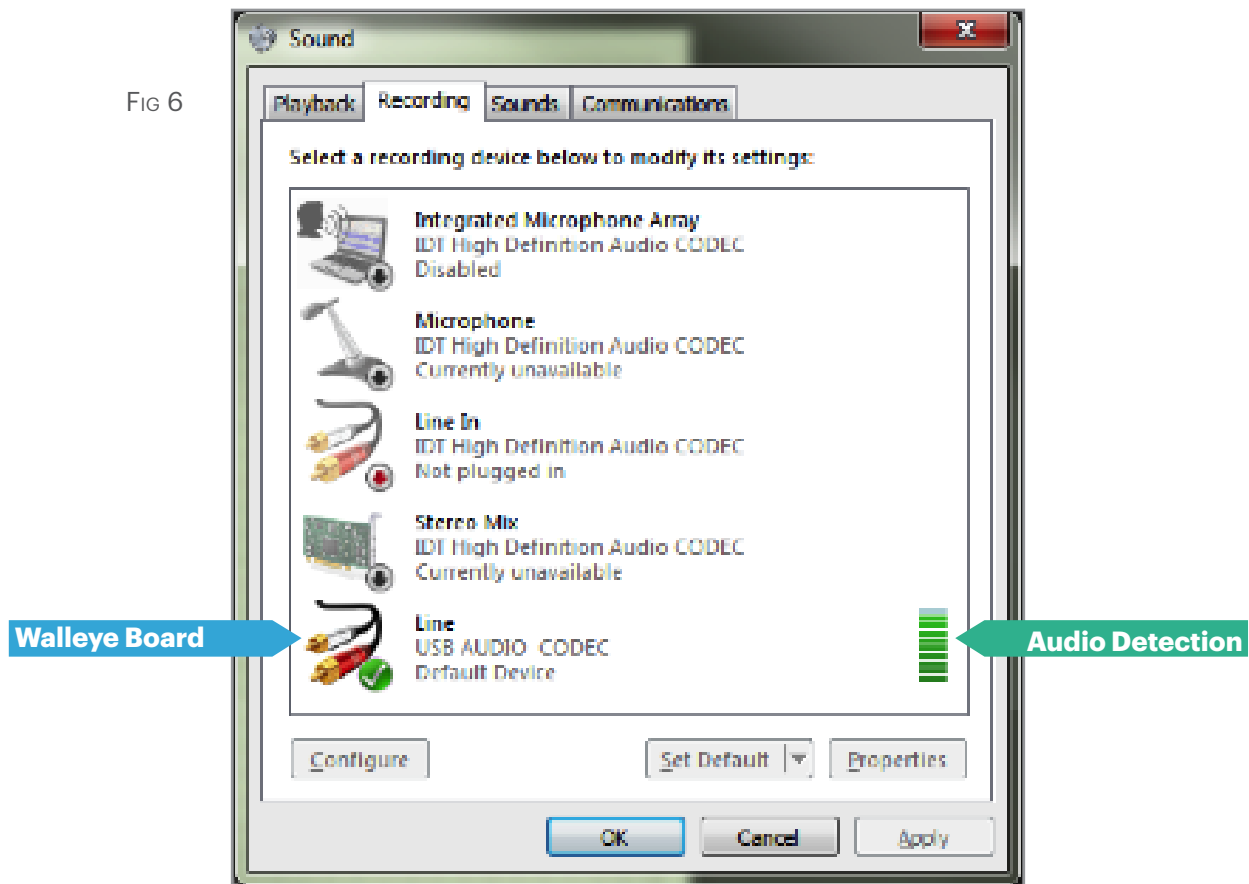

Note: Windows 7 Sound Control Panel shown. Please refer to specific OS audio configuration if using other OS.

KAS-33100-002

Walleye Board Setups

Clocks/Audio Codec

Audio Codec

The Walleye board contains a highly integrated, 24-bit, 96 kHz, low power stereo CODEC. The codec communicates to the digital mics thru an I2S bus. The Walleye board is equipped with the ability to use an internal or external clock signal input to the CS42L51 codec. The codec allows for infinite sample rate adjustment between 4 kHz and 96 kHz.

Option 1 using an Internal Clock

The Walleye board has a 12.288MHz crystal that provides an input clock to the MCLK pin of the codec.

When the BCLK DIV/2 jumper is installed the codec will output a 6.144MHz BCLK (Mic CLK signal) clock along with a 96KHz LRCK (Mic WS signal) clock. When the BCLK DIV/2 jumper is NOT installed the codec will output a 3.072MHz BCLK clock along with a 48KHz LRCK clock.

For I2S digital microphones these clocks are then level shifted to Mic VDD levels (based on the MIC VDD Select switch).

For PDM digital microphones these clocks are converted from the I2S output of the codec to PDM format. The clocks are then level shifted to Mic VDD levels (based on the MIC VDD Select switch).

Option 2 using an External Clock

By installing the EXTERNAL CLOCK ENABLE jumper an external clock can be input into the Walleye board thru the EXTERNAL CLOCK BNC type connector.

The input clock signal shall be comprised of the following:
0V to +2.5Vpp 50% duty cycle square wave.

Input clock frequency range 512KHz to 12.288Mhz (with BCLK DIV/2 jumper removed).

Note: The BCLK DIV/2 jumper is applicable only to digital microphones. If testing analog microphones BCLK DIV/2 jumper has no relevance.

External VDD Connection

The Walleye board can accept an external VDD source. Setting the MIC VDD Select switch to EXT V+ will enable the path. The connection is made thru the EXTERNAL VDD BNC type connector. The BNC center pin is the positive conductor and the shell is the ground conductor.

The input voltage range is 1.65V to 4V at 200mA.

The walleye board has an over voltage protection circuit which will activate at ~4.3V.

The external VDD input also has reverse battery protection.

If either of these faults are detected the fault voltage is isolated from the rest of the board and the microphone under test. Either fault will also light the fault detection led.

Note: If walleye board has the optional battery attached, the battery does not charge using External VDD voltage. Battery charging is accomplished only thru USB voltage.

Walleye Microphone Evaluation Kit

Taking Measurements

FIG 7

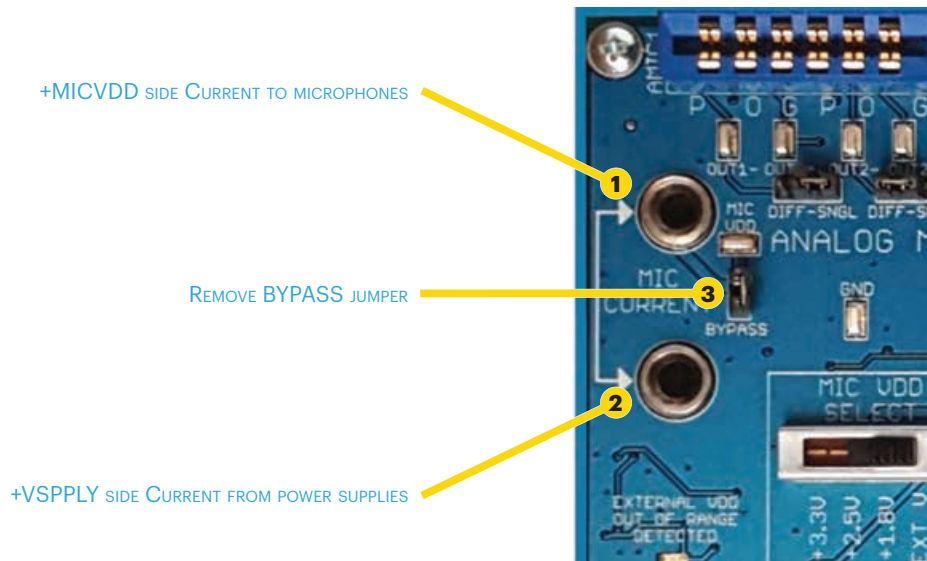

Measuring Microphone Current

1. **Microphone current can be measured across the MIC CURRENT terminals.**
2. **Attach current measuring equipment across the Mic Current terminals.** The terminal located closest to the top of the board is microphone under test side (+MICVDD). The terminal below that is the source side (+VSPPLY).
3. **Remove the BYPASS jumper to enable.**

Note: The +MICVDD signal is bussed across all Walleye board microphone connectors. The current measured will be a total of all microphones connected.

KAS-33100-002

Taking Measurements (cont'd)

FIG 8

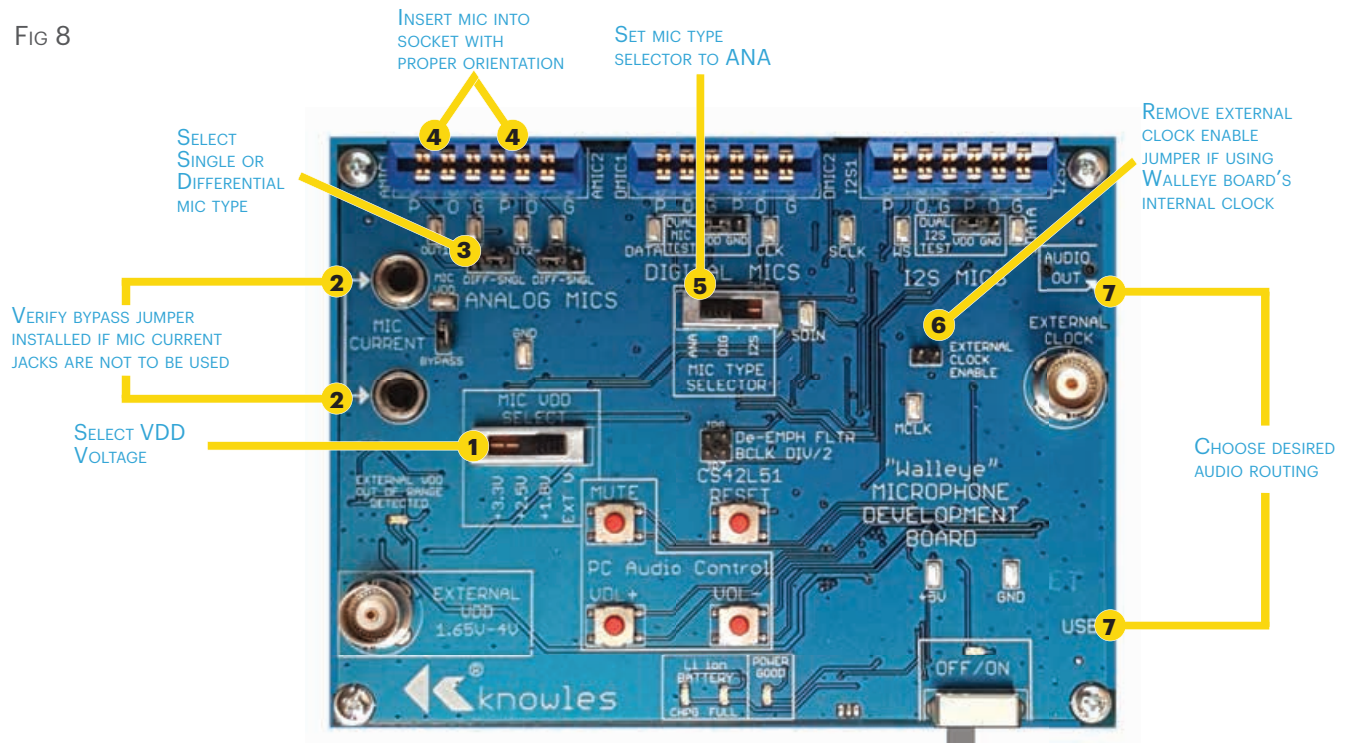

Analog Mics

The Walleye board can operate one or two analog microphones. This can be a combination of single ended and differential microphones.

1. **Select VDD Voltage.**
2. **Verify bypass jumper installed if Mic Current Jacks are not to be used.**
3. **Select Single or Differential Mic Type.**
4. **Insert Mic into socket with proper orientation.** Align POG markings on coupon with POG markings on PCB.
5. **Set Mic Type Selector to ANA.**
6. **Remove External Clock Enable jumper if using Walleye board's internal clock.**
7. **Choose desired audio routing.** Connect to 3.5mm headset jack or use the USB audio input on PC.

Set Power switch to ON to activate. Begin audio monitoring.

Note: If using 2 mics one mic audio will appear in the left channel and the other in the right channel.

Walleye Microphone Evaluation Kit

Taking Measurements (cont'd)

FIG 9

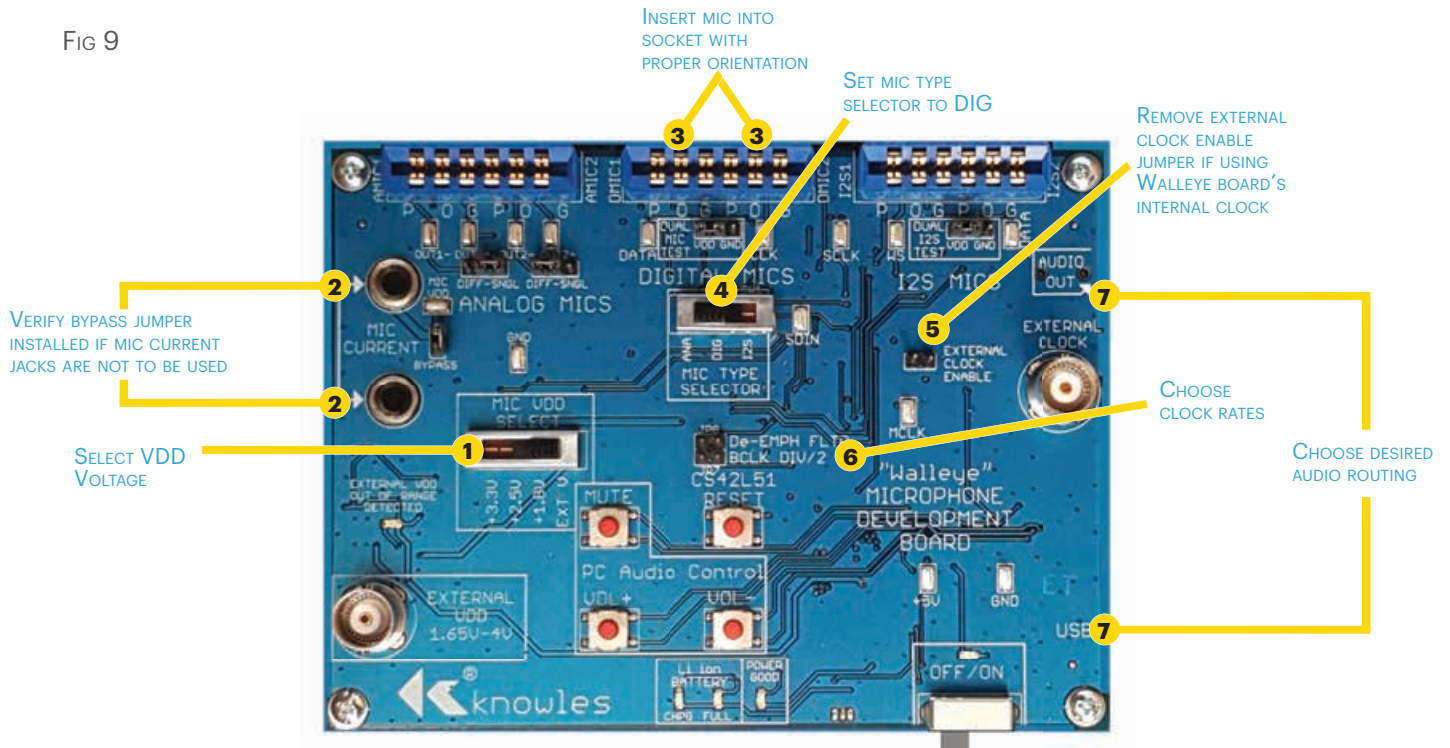

Digital Mics

The Walleye board can operate one or two digital PDM microphones.

1. **Select VDD Voltage.**
2. **Verify bypass jumper installed if Mic Current Jacks are not to be used.**
3. **Insert Mic into socket with proper orientation.** Align POG markings on coupon with POG markings on PCB.
4. **Set Mic Type Selector to DIG.**
5. **Remove External Clock Enable jumper if using Walleye board's internal clock.**
6. **Choose Clock Rates.**
7. **Choose desired audio routing.** Connect to 3.5mm headset jack or use the USB audio input on PC.

Set Power switch to ON to activate. Begin audio monitoring.

Note: If using 2 mics one mic audio will appear in the left channel and the other in the right channel.

KAS-33100-002

Taking Measurements (cont'd)

FIG 10

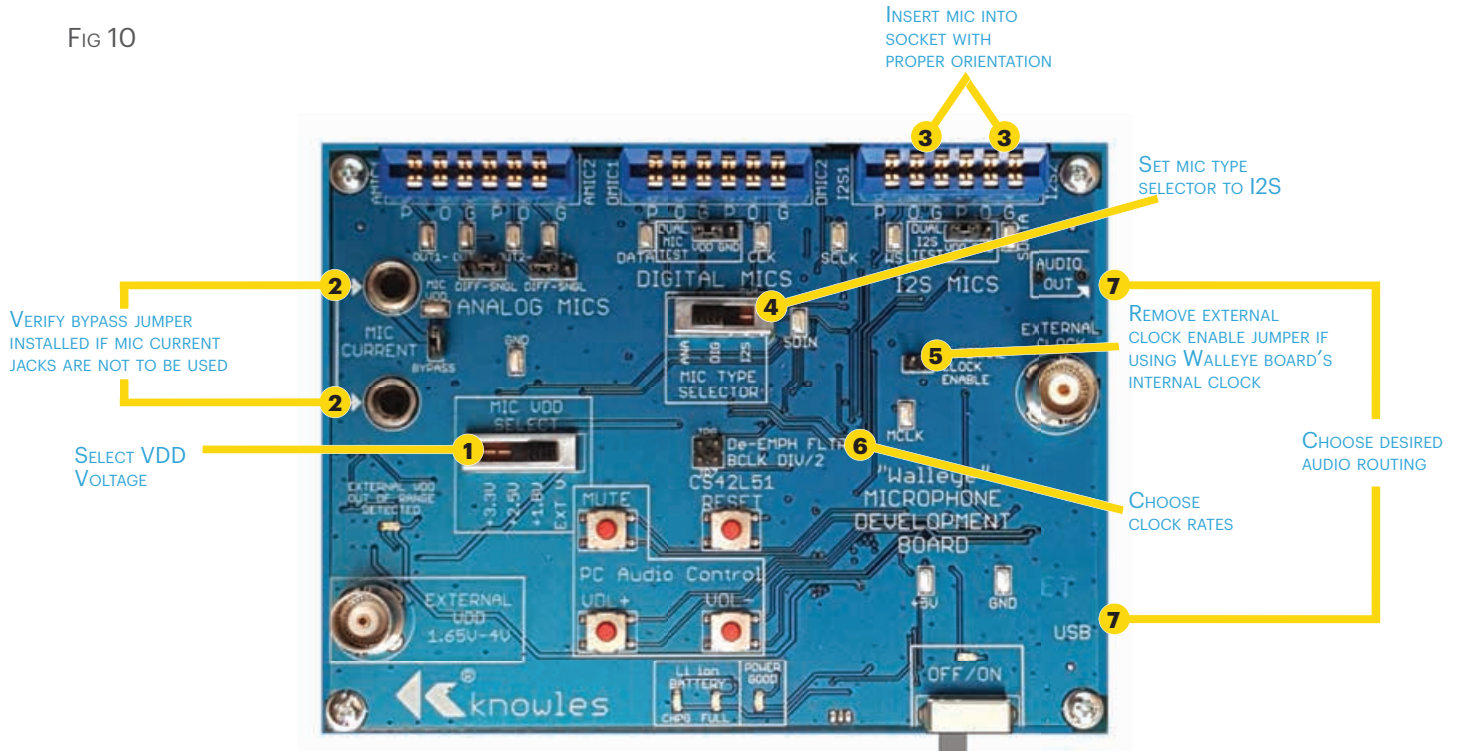

I2S Digital Mics

The Walleye board can operate one or two digital I2S microphones.

1. **Select VDD Voltage.**
2. **Verify bypass jumper installed if Mic Current Jacks are not to be used.**
3. **Insert Mic into socket with proper orientation.** Align POG markings on coupon with POG markings on PCB.
4. **Set Mic Type Selector to I2S.**
5. **Remove External Clock Enable jumper if using Walleye board's internal clock.**
6. **Choose Clock Rates.**
7. **Choose desired audio routing.** Connect to 3.5mm headset jack or use the USB audio input on PC.

Set Power switch to ON to activate. Begin audio monitoring.

Note: If using 2 mics one mic audio will appear in the left channel and the other in the right channel.



1151 Maplewood Drive
Itasca, IL 60143
630-250-5100
www.knowles.com

X-ON Electronics

Largest Supplier of Electrical and Electronic Components

Click to view similar products for [Audio IC Development Tools](#) category:

Click to view products by [Knowles](#) manufacturer:

Other Similar products are found below :

[1580/5171-DEMO](#) [LM4935RLEVAL](#) [LM4923LQBD](#) [MAX9738EVKIT+](#) [EVAL-ADAV803EBZ](#) [CDBWM8725-M-1](#) [CDBWM8533-M-1](#)
[EV_ICS-40740-FX](#) [SDCK3](#) [PIM524](#) [DEV-17737](#) [EVALAHNBIM69D130V01TOBO1](#) [1063](#) [TAS5756MDCAEVM](#)
[TLV320ADC3101EVM-K](#) [TLV320AIC3105EVM-K](#) [TLV320DAC32EVM-PDK](#) [TPA2016D2EVM](#) [TPA2035D1EVM](#)
[TPA2051D3YFFEVM](#) [TPA3107D2EVM](#) [TPA6120A2EVM](#) [TPA6132A2EVM2](#) [MIKROE-2454](#) [1381](#) [MIKROE-2477](#) [1712](#) [175](#) [1788](#)
[PGA2505EVM](#) [LM4780TABD/NOPB](#) [2130](#) [2220](#) [EVAL-ADAU1442EBZ](#) [AD8273-EVALZ](#) [2341](#) [2342](#) [TPA2100P1EVM](#)
[TPA203XD1EVM](#) [TPA2031D1EVM](#) [TPA2014D1EVM](#) [TPA2006D1EVM](#) [DEM-PCM2912AEVM](#) [TLV320AIC3204EVM-K](#)
[TLV320AIC3120EVM-U](#) [TLV320AIC3106EVM-K](#) [TLV320AIC3101EVM-K](#) [PCM2906CEVM-U](#) [TAS5132DDV2EVM](#) [2716](#)