

# Silicon Carbide Schottky Diode 650V, 6A, 15nC

## General Description

This product family offers state of the art performance. It is designed for high frequency applications where high efficiency and high reliability are required.

## Features

- Zero Forward/Reverse Recovery
- High Blocking Voltage
- High Frequency Operation
- Positive Temperature Coefficient on  $V_F$
- Temperature Independent Switching Behavior

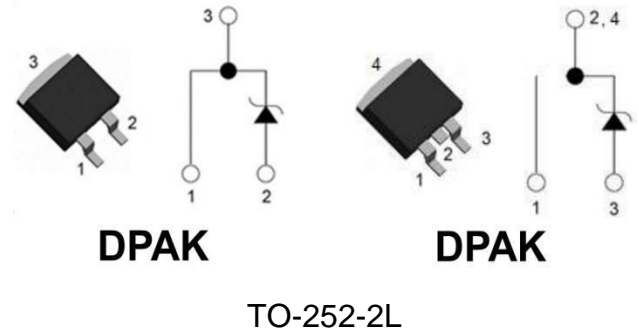

## Applications

- Switch Mode Power Supplies
- Server Power Supplies
- Solar Inverters
- AC/DC converters
- DC/DC converters
- Uninterruptable power supplies

## Benefits

- Higher System Efficiency
- Parallel Device Convenience
- High Frequency Operation
- High Temperature Application
- Hard Switching & High Reliability
- Environmental Protection

## Key performance parameters

| Type       | $V_R$ | $I_F$<br>$T_C=150^\circ\text{C}$ | $Q_C$ |
|------------|-------|----------------------------------|-------|
| KN3D06065F | 650V  | 6A                               | 15nC  |

### Maximum Ratings

$T_C=25^\circ\text{C}$ , unless otherwise specified

| Parameter                       | Symbol    | Value | Unit |
|---------------------------------|-----------|-------|------|
| Peak Repetitive Reverse Voltage | $V_{RRM}$ | 650   | V    |
| Peak Reverse Surge Voltage      | $V_{RSM}$ | 650   | V    |
| DC Blocking Voltage             | $V_R$     | 650   | V    |

### Maximum Ratings

$T_C=25^\circ\text{C}$ , unless otherwise specified

| Parameter  | Symbol    | Value      | Unit             |
|--|-----------|------------|------------------|
| Continuous Forward Current:<br><br>$T_C = 25^\circ\text{C}$<br>$T_C = 135^\circ\text{C}$<br>$T_C = 150^\circ\text{C}$  | $I_F$     | 19         | A                |
|  |           | 8          |                  |
|  |           | 6          |                  |
| Non Repetitive Forward Surge Current:<br><br>$T_C = 25^\circ\text{C}$ , $t_p=10\text{ms}$ , Half Sine Pulse<br>$T_C = 110^\circ\text{C}$ , $t_p=10\text{ms}$ , Half Sine Pulse<br>$T_C = 25^\circ\text{C}$ , $t_p=10 \mu\text{s}$ , Square | $I_{FSM}$ | 40         | A                |
|  |           | 35         |                  |
|  |           | 250        |                  |
| Repetitive peak Forward Surge Current:<br><br>Freq = 0.1Hz, 100 cycles<br>$T_C = 25^\circ\text{C}$ , $t_p=10\text{ms}$ , Half Sine Pulse<br>$T_C = 110^\circ\text{C}$ , $t_p=10\text{ms}$ , Half Sine Pulse                                | $I_{FRM}$ | 35         | A                |
|  |           | 30         |                  |
|  |           |            |                  |
| Total power dissipation :<br>$T_C = 25^\circ\text{C}$  | $P_D$     | 67         | W                |
| Operating Junction Temperature :   | $T_j$     | -55 to 175 | $^\circ\text{C}$ |
| Storage Temperature :  | $T_{stg}$ | -55 to 175 | $^\circ\text{C}$ |

### Thermal Resistance

| Parameter                         | Symbol        | Typ. | Max | Unit |
|-----------------------------------|---------------|------|-----|------|
| Thermal resistance, junction-case | $R_{th(j-c)}$ | 2.25 |     | °C/W |

### Electrical Characteristic

*TC = 25°C, unless otherwise specified*

| Parameter                | Symbol   | Value |                      |      | Unit    | Test Condition   |
|--------------------------|----------|-------|----------------------|------|---------|--|
|                          |          | Min.  | Typ.                 | Max. |         |  |
| DC Blocking Voltage      | $V_{DC}$ | 650   |                      |      | V       | $I_R = 250\mu A$<br>$T_J = 25^\circ C$   |
| Forward Voltage          | $V_F$    |       | 1.43<br>1.58<br>1.72 | 1.75 | V       | $I_F = 6A$<br>$T_J = 25^\circ C$<br>$T_J = 125^\circ C$<br>$T_J = 175^\circ C$   |
| Reverse Current          | $I_R$    |       | 5<br>38<br>110       | 50   | $\mu A$ | $V_R = 650V$<br>$T_J = 25^\circ C$<br>$T_J = 125^\circ C$<br>$T_J = 175^\circ C$ |
| Total Capacitance Charge | $Q_C$    |       | 15                   |      | nC      | $V_R = 400V$   |
| Total Capacitance        | C        |       | 235<br>28<br>22      |      | pF      | $T_J = 25^\circ C, F_{req} = 1MHz$<br>$V_R = 1V$<br>$V_R = 200V$<br>$V_R = 400V$ |

## Characteristics Curves

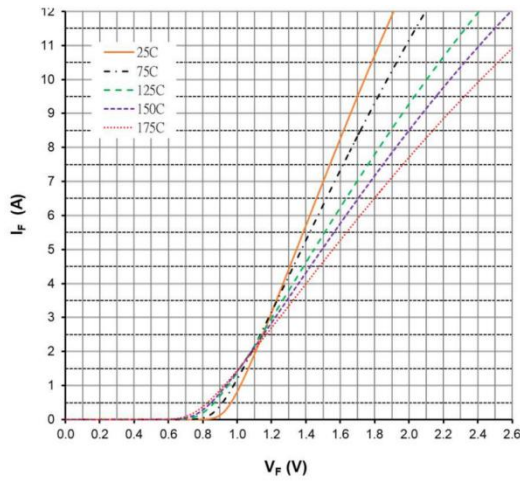

Figure 1. Forward Characteristics

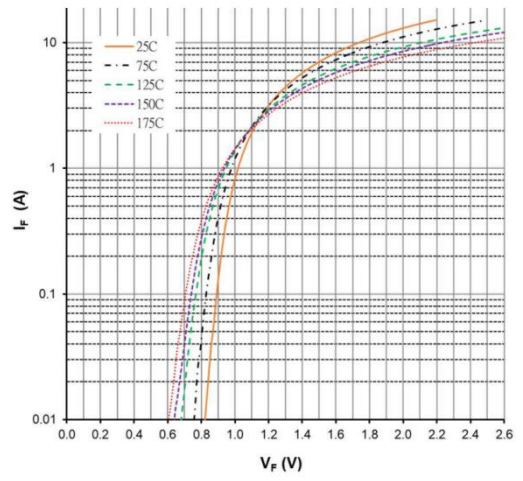

Figure 2. Forward Characteristics

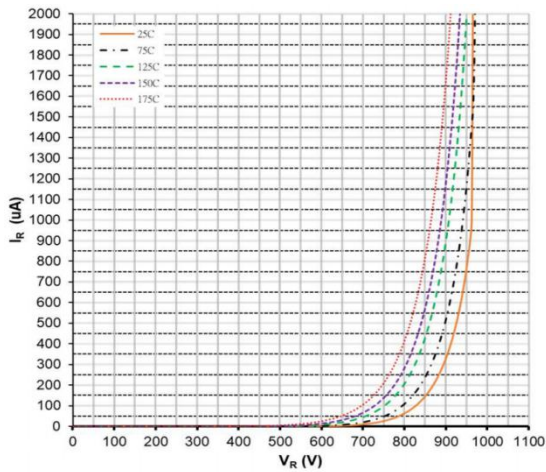

Figure 3. Reverse Characteristics

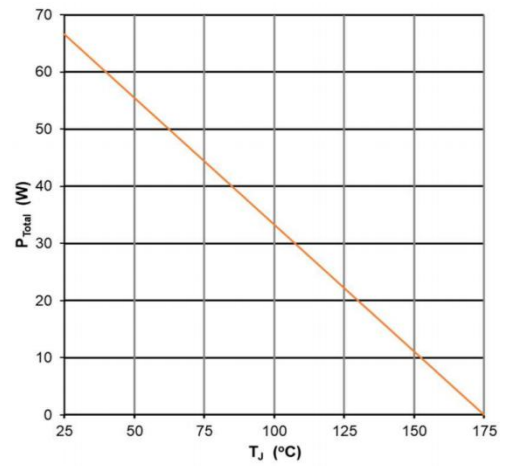

Figure 4. Power Derating

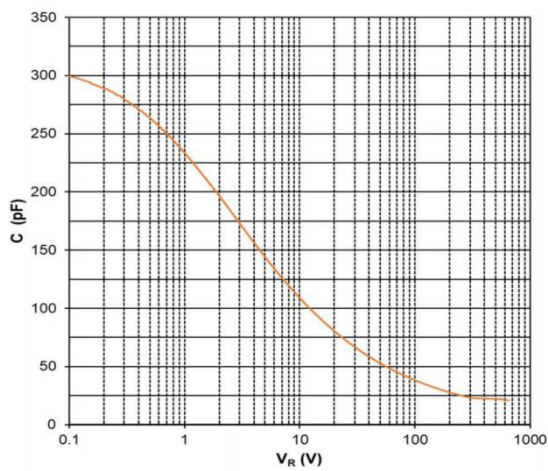

Figure 5. Capacitance vs Reverse Voltage

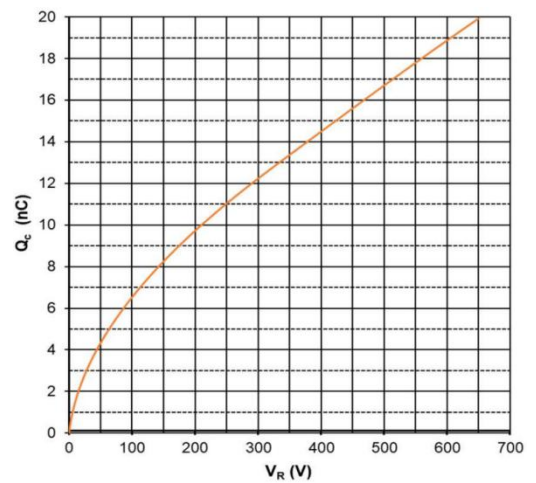
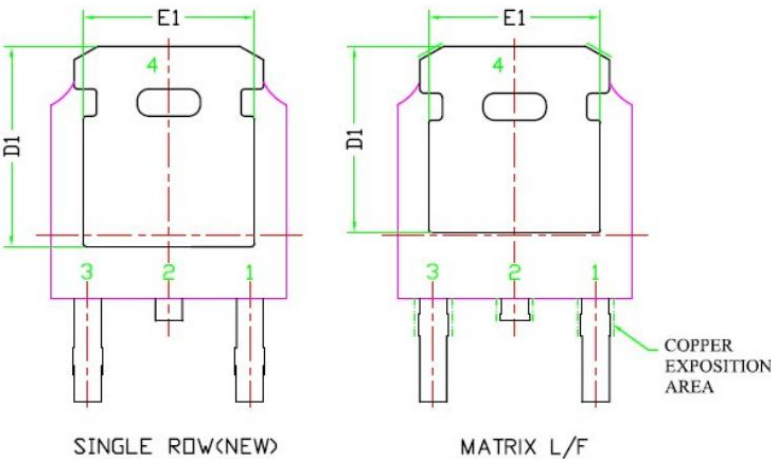
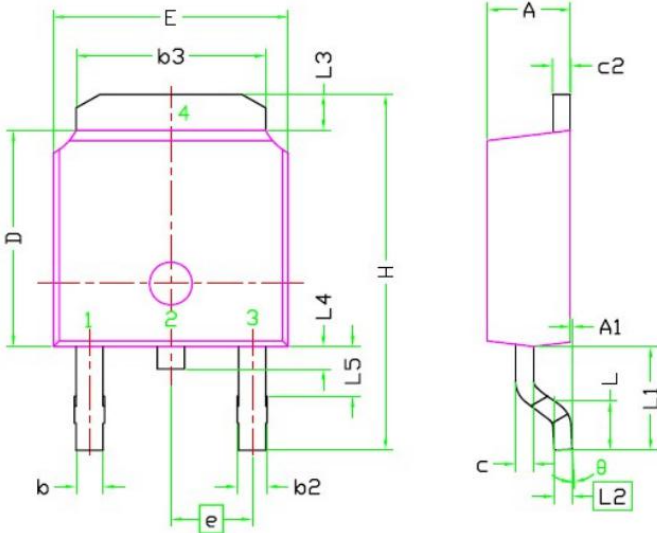

Figure 6. Recovery Charge vs Reverse Voltage

### Package Dimensions: (DPAK Package)



| SYMBOL | DIMENSIONAL REQMTS |       |       |
|--------|--------------------|-------|-------|
|        | MIN                | NOM   | MAX   |
| E      | 6.40               | 6.60  | 6.731 |
| L      | 1.40               | 1.52  | 1.77  |
| L1     | 2.743 REF          |       |       |
| L2     | 0.508 BSC          |       |       |
| L3     | 0.89               | --    | 1.27  |
| L4     | 0.64               | --    | 1.01  |
| L5     | --                 | --    | --    |
| D      | 6.00               | 6.10  | 6.223 |
| H      | 9.40               | 10.00 | 10.40 |
| b      | 0.64               | 0.76  | 0.88  |
| b2     | 0.77               | 0.84  | 1.14  |
| b3     | 5.21               | 5.34  | 5.46  |
| e      | 2.286 BSC          |       |       |
| A      | 2.20               | 2.30  | 2.38  |
| A1     | 0                  | --    | 0.127 |
| c      | 0.46               | 0.50  | 0.60  |
| c2     | 0.46               | 0.50  | 0.58  |
| D1     | 5.21               | --    | --    |
| E1     | 4.40               | --    | --    |

Note:

1. All Dimension Are In mm.
2. Package Body Sizes Exclude Mold Flash, Protrusion Or Gate Burrs. Mold Flash, Protrusion Or Gate Burrs Shall Not Exceed 0.10 mm Per Side.
3. Package Body Sizes Determined At The Outermost Extremes Of The Plastic Body Exclusive Of Mold Flash, Gate Burrs And Interlead Flash, But Including Any Mismatch Between The Top And Bottom Of The Plastic Body.
4. The Package Top May Be Smaller Than The Package Bottom.
5. Dimension "b" Does Not Include Dambar Protrusion. Allowable Dambar Protrusion Shall Be 0.10 mm Total In Excess Of "b" Dimension At Maximum Material Condition. The Dambar Cannot Be Located On The Lower Radius Of The Foot.

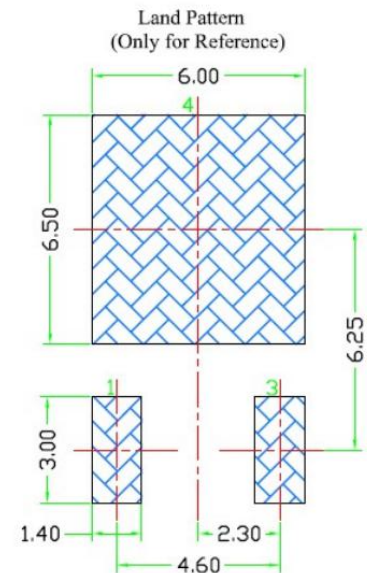

### (DPAK Package)

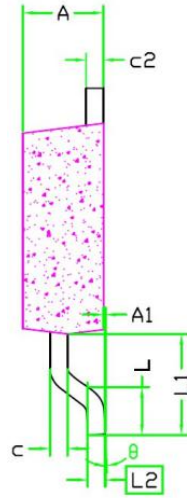
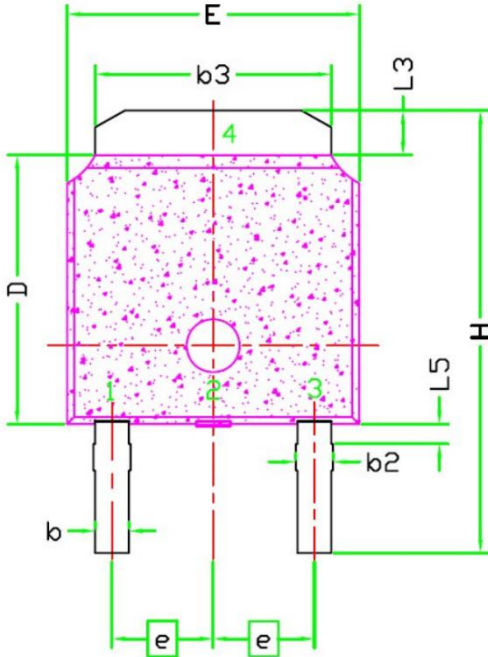

| SYMBOL   | DIMENSIONAL REQMTS |       |       |
|----------|--------------------|-------|-------|
|          | MIN                | NOM   | MAX   |
| E        | 6.40               | 6.60  | 6.731 |
| L        | 1.40               | 1.52  | 1.77  |
| L1       | 2.743 REF          |       |       |
| L2       | 0.508 BSC          |       |       |
| L3       | 0.89               | --    | 1.27  |
| L5       | --                 | --    | --    |
| D        | 6.00               | 6.10  | 6.223 |
| H        | 9.40               | 10.00 | 10.40 |
| b        | 0.64               | 0.76  | 0.88  |
| b2       | 0.77               | 0.84  | 1.14  |
| b3       | 5.21               | 5.34  | 5.46  |
| e        | 2.286 BSC          |       |       |
| A        | 2.20               | 2.30  | 2.38  |
| A1       | 0                  | --    | 0.127 |
| c        | 0.46               | 0.50  | 0.60  |
| c2       | 0.46               | 0.50  | 0.58  |
| D1       | 5.21               | --    | --    |
| E1       | 4.40               | --    | --    |
| $\theta$ | 0°                 | --    | 10°   |

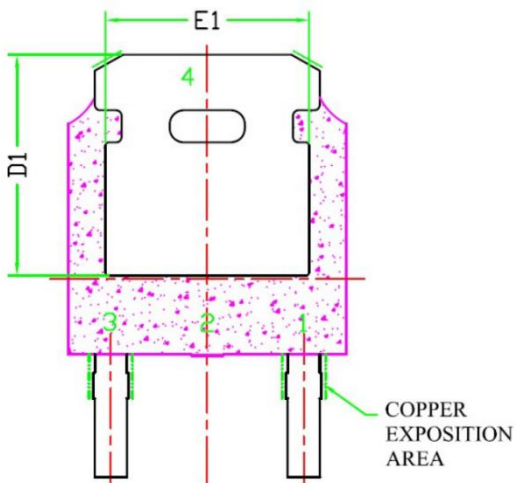

Note:

1. All Dimension Are In mm.
2. Package Body Sizes Exclude Mold Flash, Protrusion Or Gate Burrs. Mold Flash, Protrusion Or Gate Burrs Shall Not Exceed 0.10 mm Per Side.
3. Package Body Sizes Determined At The Outermost Extremes Of The Plastic Body Exclusive Of Mold Flash, Gate Burrs And Interlead Flash, But Including Any Mismatch Between The Top And Bottom Of The Plastic Body.
4. The Package Top May Be Smaller Than The Package Bottom.
5. Dimension "b" Does Not Include Dambar Protrusion. Allowable Dambar Protrusion Shall Be 0.10 mm Total In Excess Of "b" Dimension At Maximum Material Condition. The Dambar Cannot Be Located On The Lower Radius Of The Foot.

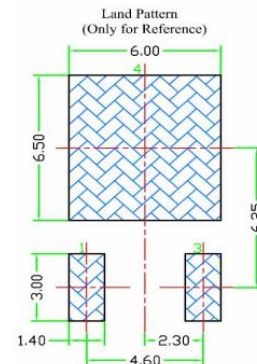

| Part Number | Package   | Packing           | Marking    | M.O.Q |
|-------------|-----------|-------------------|------------|-------|
| KN3D06065F  | TO-252-2L | 2500pcs/Tape&Reel | KN3D06065F | 2500  |



## X-ON Electronics

Largest Supplier of Electrical and Electronic Components

*Click to view similar products for [Schottky Diodes & Rectifiers](#) category:*

*Click to view products by [KNSCHA](#) manufacturer:*

Other Similar products are found below :

[MA4E2039](#) [MA4E2508M-1112](#) [MBR1545CT](#) [MMBD301M3T5G](#) [RB160M-50TR](#) [D83C](#) [BAS16E6433HTMA1](#) [BAT 54-02LRH E6327](#)  
[NRVBAF360T3G](#) [NSR05F40QNXT5G](#) [NTE555](#) [JANS1N6640](#) [SK310-T](#) [SK34B-TP](#) [SS3003CH-TL-E](#) [GA01SHT18](#)  
[CRS10I30A\(TE85L,QM](#) [MA4E2501L-1290](#) [MBRA140TRPBF](#) [MBRB30H30CT-1G](#) [BAT 15-04R E6152](#) [JANTX1N5712-1](#) [DMJ3940-000](#)  
[SB007-03C-TB-E](#) [SK33B-TP](#) [NRVBB20100CTT4G](#) [NRVBM120LT1G](#) [NTSB30U100CT-1G](#) [VS-6CWQ10FNHM3](#) [CRG04\(T5L,TEMQ\)](#)  
[ACDBA1100LR-HF](#) [ACDBA1200-HF](#) [ACDBA240-HF](#) [ACDBA3100-HF](#) [CDBQC0530L-HF](#) [CDBQC0240LR-HF](#) [ACDBA260LR-HF](#)  
[ACDBA1100-HF](#) [MA4E2502L-1246](#) [10BQ015-M3/5BT](#) [NRVBM120ET1G](#) [CRS08TE85LQM](#) [PMAD1108-LF](#) [B120Q-13-F](#) [1N5819T-G](#)  
[B0530WSQ-7-F](#) [PDS1040Q-13](#) [B160BQ-13-F](#) [SDM05U20CSP-7](#) [B140S1F-7](#)