

METAL FILM (PRECISION)

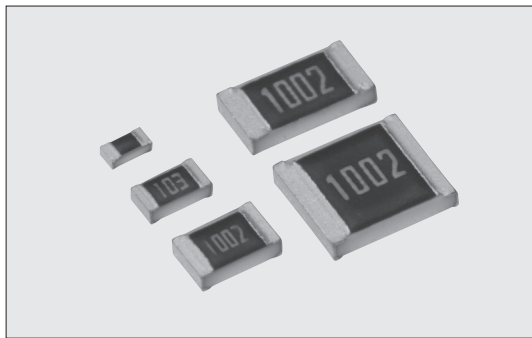

矩形片式电阻器
Flat Chip Resistors

RN73H 矩形金属膜片式电阻器 (高可靠性) Metal Film Flat Chip Resistors (High reliability)



外观颜色: 黑色 Coating color: Black

特点 Features

- 贴片金属膜电阻器。
- 也标准对应高精度的阻值允许偏差 $\pm 0.05\%$ 。
- 也标准对应高精度的电阻温度系数 $\pm 5 \times 10^{-6}/K$ 。
- 电流噪声低。
- 使用温度范围 $\sim 155^{\circ}C$ 。额定环境温度: $85^{\circ}C$ 。
- 用特殊防护涂层提高耐湿性。
- 适合于各种工业设备中的控制线路。
- 对应回流焊, 波峰焊。
- 符合欧盟RoHS。
- AEC-Q200相关数据已取得。
- SMD metal film resistors.
- High precision type $\pm 0.05\%$ is available with standard products.
- High performance T.C.R. $\pm 5 \times 10^{-6}/K$ is available.
- Low current noise.
- Operating temperature range $\sim 155^{\circ}C$.
- Rated ambient temperature: $85^{\circ}C$
- Improved moisture resistance by special protective coating.
- Suitable for control circuits in various industrial equipment.
- Suitable for both flow and reflow solderings.
- Products meet EU-RoHS requirements.
- AEC-Q200 qualified.

用途 Applications

- 汽车电子装置 Car electronics
- 工业设备 Industrial equipment
- 医疗设备 Medical equipment

参考标准 Reference Standards

IEC 60115-8
JIS C 5201-8
EIAJ RC-2133A

额定值 Ratings

型号 Type	额定功率 Power Rating	额定环境温度 Rated Ambient Temp.	额定端子部温度 Rated Terminal Part Temp.	电阻温度系数 T.C.R. ($\times 10^{-6}/K$)	电阻值范围 Resistance Range (Ω) E24 • E96 • E192					最高使用电压 Max. Working Voltage	最高过载电压 Max. Overload Voltage	编带和包装数/卷 Taping & Q'ty/Reel (pcs)		
					A: $\pm 0.05\%$	B: $\pm 0.1\%$	C: $\pm 0.25\%$	D: $\pm 0.5\%$	F: $\pm 1\%$			TP	TD	TE
					± 10	± 25	± 50	± 100	± 1000					
1E	0.063W	$85^{\circ}C$	$90^{\circ}C$	± 10	-	47~10k	47~10k	47~10k	47~10k	50V	100V	10,000	-	-
1J	0.1W	$85^{\circ}C$	$95^{\circ}C$	± 5	100~59k	100~59k	-	-	-	75V	150V	-	5,000	-
				± 10	47~59k	47~360k	47~360k	47~360k	47~360k					
				± 25	47~59k	15~1M	15~1M	10~1M	10~1M					
				± 50	-	15~1M	15~1M	10~1M	10~1M					
				± 100	-	-	10~1M	10~1M						
2A	0.125W	$85^{\circ}C$	$100^{\circ}C$	± 5	100~100k	100~100k	-	-	-	150V	300V	-	5,000	4,000
				± 10	47~100k	47~1M	47~1M	47~1M	47~1M					
				± 25	47~100k	15~1.5M	15~1.5M	10~1.5M	10~1.5M					
				± 50	-	15~1.5M	15~1.5M	10~1.5M	10~1.5M					
				± 100	-	-	10~1.5M	10~1.5M						
2B	0.25W	$85^{\circ}C$	$110^{\circ}C$	± 5	100~300k	100~300k	-	-	-	200V	400V	-	5,000	4,000
				± 10	47~300k	47~1M	47~1M	47~1M	47~1M					
				± 25	47~300k	15~1M	15~1M	10~1M	10~1M					
				± 50	-	15~1M	15~1M	10~1M	10~1M					
				± 100	-	-	10~1M	10~1M						
2E	0.25W	$85^{\circ}C$	$110^{\circ}C$	± 10	100~510k	100~510k	100~510k	100~510k	100~510k	200V	400V	-	5,000	4,000
				± 25	51~510k	15~1M	15~1M	10~1M	10~1M					
				± 50	-	15~1M	15~1M	10~1M	10~1M					
				± 100	-	-	10~1M	10~1M						
				± 1000	-	-	10~1M	10~1M						

使用温度范围 Operating Temperature Range: $-55^{\circ}C \sim +155^{\circ}C$

额定电压是 $\sqrt{\text{额定功率} \times \text{公称电阻值}}$ 所算出的值或表中最高使用电压两者中的值为额定电压。

Rated voltage = $\sqrt{\text{Power Rating} \times \text{Resistance value}}$ or Max. working voltage, whichever is lower.

根据客户的使用状况, 如果不清楚是该使用额定环境温度还是额定端子部温度, 请以额定端子部温度为优先。

详情请参照14~17页的“端子部温度负荷特性曲线的说明”。

If any questions arise whether to use the "Rated Ambient Temperature" or the "Rated Terminal Part Temperature" in your usage conditions, please give priority to the "Rated Terminal Part Temperature".

For more details, please refer to "Introduction of the derating curves based on the terminal part temperature" in page 14 to 17.

结构图 Construction

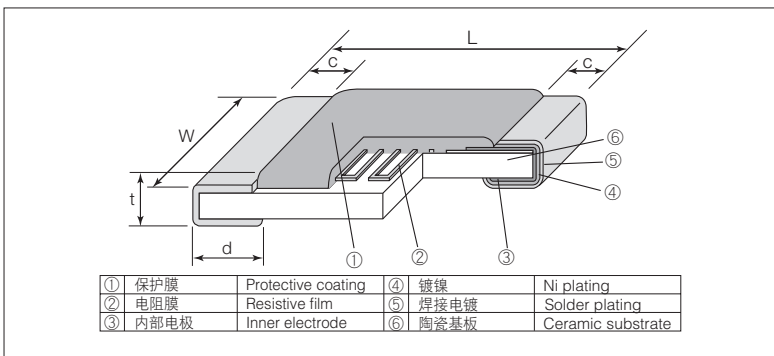

外形尺寸 Dimensions

型号 Type (Inch Size Code)	尺寸 Dimensions (mm)					Weight (g) (1000pcs)
	L	W	c	d	t	
1E (0402)	$1.0^{+0.1}_{-0.05}$	0.5 ± 0.05	0.25 ± 0.10	$0.25^{+0.05}_{-0.1}$	0.35 ± 0.05	0.68
1J (0603)	1.6 ± 0.2	0.8 ± 0.1	0.3 ± 0.1	0.3 ± 0.1	0.45 ± 0.1	2.14
2A (0805)	2.0 ± 0.2	1.25 ± 0.2	0.4 ± 0.2	$0.3^{+0.2}_{-0.1}$	0.5 ± 0.1	4.54
2B (1206)	3.2 ± 0.2	1.6 ± 0.2	0.5 ± 0.3	$0.4^{+0.2}_{-0.1}$	0.6 ± 0.1	9.14
2E (1210)		2.5 ± 0.2				14.5

品名构成 Type Designation

实例 Example	品种 Product Code	额定功率 Power Rating	端子表面材质 Terminal Surface Material	二次加工 Taping	公称电阻值 Nominal Resistance	阻值允许偏差 Resistance Tolerance	电阻温度系数 T.C.R. ($\times 10^{-6}/K$)
RN73H	2B	T	TD	1002	B	25	
		1E:0.063W 1J:0.1W 2A:0.125W 2B:0.25W 2E:0.25W	T:Sn G:Au*1	TP:2mm pitch punch paper TD:4mm pitch paper TE:4mm pitch plastic embossed BK: Bulk	4 digits	A: $\pm 0.05\%$ B: $\pm 0.1\%$ C: $\pm 0.25\%$ D: $\pm 0.5\%$ F: $\pm 1\%$	05 10 25 50 100

*1 镀金电极品以1E、1J对应。由于规格不同, 请与本公司咨询。

*1 Products with gold plated electrodes are also available with 1E and 1J type, so please consult with us. 欲知关于此产品含有的环境负荷物质详情 (除EU-RoHS以外), 请与我们联系。

编带细节请参考卷末附录C。

Contact us when you have control request for environmental hazardous material other than the substance specified by EU-RoHS.

For further information on taping, please refer to APPENDIX C on the back pages.

■ 负荷减轻特性曲线 Derating Curve



在环境温度85℃以上使用时，应按照上图负荷减轻特性曲线，减小额定功率。

For resistors operated at an ambient temperature of 85°C or above, a power rating shall be derated in accordance with the above derating curve.



超过上述端子部温度使用时，请根据负荷减轻特性曲线减小额定功率后使用。

※关于使用方法，请参照卷首的“端子部温度负荷减轻特性曲线的说明”。

For resistors operated terminal part temperature of described for each size or above, a power rating shall be derated in accordance with derating curve.

※Please refer to “Introduction of the derating curves based on the terminal part temperature” on the beginning of our catalog before use.

■ 性能 Performance

试验项目 Test Items	标准值 Performance Requirements $\Delta R \pm (\% + 0.05 \Omega)$		试验方法 Test Methods
	保证值 Limit	代表值 Typical	
电阻值 Resistance	在规定的允许偏差内 Within specified tolerance	-	25°C
电阻温度系数 T.C.R.	在规定的值以内 Within specified T.C.R.	-	+25°C/+125°C : T.C.R. = $\pm 5 (\times 10^{-6})/K$ +25°C/-55°C and +25°C/+155°C : another
过载 (短时间) Overload (Short time)	0.05	0.01	额定电压×2.5倍或最高过载电压中低的一方施加5秒钟 Rated voltage × 2.5 or Max. overload vol., whichever is less, for 5s
耐焊接热 Resistance to soldering heat	0.05 ^{※2}	0.01	260°C ± 5°C, 10s ± 1s
温度突变 Rapid change of temperature	0.1 ^{※2}	0.02	1E, 1J, 2A : -55°C (30min.) / +155°C (30min.) 1000 cycles 2B, 2E : -55°C (30min.) / +155°C (30min.) 500 cycles
耐湿负荷 Moisture resistance	0.1 ^{※2}	0.05	85°C ± 2°C, 85% ± 5%RH, 1000h 1.5小时ON、0.5小时OFF的周期 1.5h ON/0.5h OFF cycle
在85°C时的耐久性 Endurance at 85°C	0.1	0.03	85°C ± 2°C, 3000h 1.5小时ON、0.5小时OFF的周期 1.5h ON/0.5h OFF cycle
高温放置 High temperature exposure	0.1 ^{※2}	0.05	+155°C, 1000h

※2 保证值因阻值的不同而改变

※2 Depends on resistance value

■ 使用注意事项 Precautions for Use

- 部件的编带材料使用的是采取合适的防静电措施的物质，但在实际情况下，有过度干燥状态的情况，以及编带包装后施加了长时间振动后，项带上产品吸附了静电，产生装载不良、部件受到静电（人体模型100pF, 1.5kΩ, 超过1KV: 1J, 2A, 2B, 2E, 超过0.5kV: 1E）破坏，电阻值有发生变化的危险，要注意。
- 在本产品和安装的印刷电路板上，附着了助焊剂和人的汗和唾液等离子性杂质时，耐湿性·耐腐蚀性等方面会变得不理想。产品被助焊剂中含有的氯和酸，人的汗，唾液中含有的钠，氯等离子污染时，已证实会引起电蚀。特别是使用无助焊剂时，由于湿润性的提高，会含有大量离子性物质，所以使用RMA系的焊锡或助焊剂时，请进行充分清洗。并且，涂上防湿涂层材料时，在产品 and 防湿涂层之间残留了上述杂质时，会引起进一步电蚀，因此，请在涂防湿材料前清洗。
- 贴装时，芯片电阻器上贴有耐热屏蔽胶带，如果撕下胶带，上部电极可能被剥离。已证实，由于暴露在高温下安装附着力变得更加牢固。因此，请尽量避免使用或使用确保胶带粘合剂不会直接与产品接触。此外，如进行高压冲淋清洗，水压应力可能导致上部电极剥离。因此，请尽量避免使用或事先评估后再使用。
- The properly and electrostatically measured taping materials are used for the components, but attention should be paid to the fact that there is some danger the parts absorb on the toptapes to cause a failure in the mounting and the parts are destructed by static electricity (1J, 2A, 2B, 2E: 1kV and more, 1E: 0.5kV and more at Human Body Model 100pF, 1.5kΩ) to change theresistance in the conditions of an excessive dryness or after the parts are given vibration for a long time as they are packaged on the tapes. Similarly, care should be given not to apply theexcessive static electricity when mounting on the boards.
- Ionic impurities such as flux etc. that are attached to these products or those mounted onto a PCB, negatively affect their moisture resistance, corrosion resistance, etc. The flux maycontain ionic substances like chlorine, acid, etc. while perspiration and saliva include ionic impurities like sodium (Na⁺), chlorine (Cl⁻) etc. Therefore these kinds of ionic substances mayinduce electrical corrosion when they invade into the products. Either thorough washing or using RMA solder and flux are necessary since lead free solder contains ionic substances. Washing process is needed, before putting on moisture proof material in order to prevent electrical corrosion.
- When heat-resistant masking tapes are attached to the chip resistors at the time of mounting and then detached, there is a possibility of exfoliation of the top electrodes. It is known that the heat applied in the mounting process will enhance the adhesion strength of the tape adhesive so please avoid the use. If the use of masking tapes are unavoidable, then please be sure not to attach the tape adhesives directly on the products. When high-pressure shower cleaning is implemented, there is a possibility of exfoliation of the top electrodes caused by the water pressure stress so please avoid the implementation. If the implementation is unavoidable, then please evaluate the products beforehand.

X-ON Electronics

Largest Supplier of Electrical and Electronic Components

Click to view similar products for [Thin Film Resistors - SMD category](#):

Click to view products by [KOA Speer manufacturer](#):

Other Similar products are found below :

[M55342K06B34E0RT3](#) [D55342E07B379BR-TR](#) [AR02BTC1872](#) [AR02BTC18R7](#) [AR02BTC3830](#) [AR02BTC4220](#) [AR02BTC4422](#)
[AR02BTC5100](#) [AR02BTC5111](#) [AR02BTC5762](#) [AR02BTC8251](#) [AR02BTC8452](#) [AR03BTC0110](#) [AR03BTC0120](#) [AR03BTC0330](#)
[AR03BTC0390](#) [AR03BTC1102](#) [AR03BTC1103](#) [AR03BTC1201](#) [AR03BTC2000](#) [AR03BTC2201](#) [AR03BTC2203](#) [AR03BTC2490](#)
[AR03BTC3003](#) [AR03BTC4220](#) [AR03BTC4223N](#) [AR03BTC5602](#) [AR03BTC5603](#) [AR03BTC5900](#) [AR03BTC6802](#) [AR03BTC7500](#)
[AR03BTC9100](#) [AR03BTC9103](#) [AR03BTC9760](#) [AR05BTC0280](#) [AR05BTC1000](#) [AR05BTC1100](#) [AR05BTC1201](#) [AR05BTC1202](#)
[AR05BTC1300](#) [AR05BTC14R3](#) [AR05BTC1500](#) [AR05BTC1523](#) [AR05BTC1620](#) [AR05BTC1622](#) [AR05BTC1623](#) [AR05BTC1760](#)
[AR05BTC1800](#) [AR05BTC1823](#) [AR05BTC1871](#)