

## Description

The KN431 series are 3-terminal precision shunt regulators that are programmable over a wide voltage range of 2.495V to 36V with  $\pm 0.3\%$ ,  $\pm 0.5\%$ ,  $\pm 1.0\%$  tolerance. The KN431 series have a low dynamic impedance of  $0.15\Omega$ . These features make the KN431 series an excellent replacement for zener diodes in numerous applications circuits that require a precision reference voltage.

## Features

Programmable output voltage from 2.495V to 36V

Voltage reference tolerance :  $\pm 0.3\%$ ,  $\pm 0.5\%$ ,  $\pm 1.0\%$

Cathode current capability of 1mA to 100mA

ESD ratings : 2000V (HBM), 200V (MM)

## Pin Assignment

(Top View)



PKG : SOT-89

Apply Device : KN431xF

(Top View)



PKG : SOT-23

Apply Device : KN431xS

(Top View)



PKG : SOT-23

Apply Device : KNF431xS

(Top View)

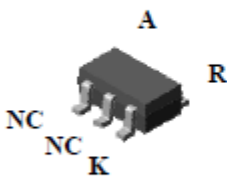

PKG : SOT-25

Apply Device : KN431xN

(Marking Side View)



PKG : TO-92

Apply Device : KN431x

(Marking Side View)



PKG : TO-92M

Apply Device : KN431xM

[ K : Cathode, A: Anode, R : Reference ]

## Symbol

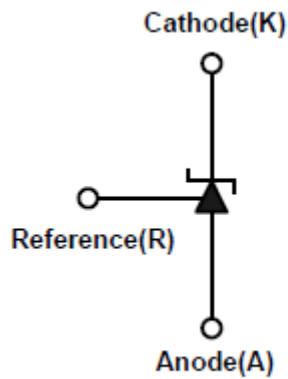

## Functional block diagram

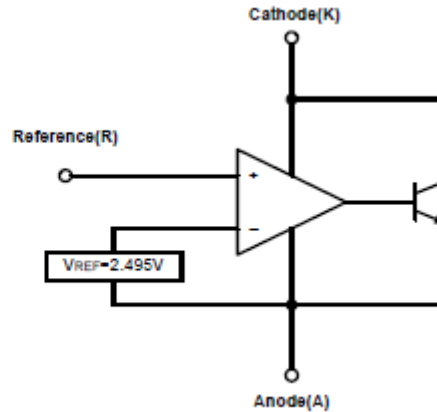

## Ordering Information

Vref Tolerance	PKG Type	Device Name	Marking
±1%	TO-92	KN431A	KN431 A•
	TO-92M	KN431AM	KN431 A•
	SOT-23	KN431AS <sup>1)</sup>	4GA□ <sub>3)</sub> △•
	SOT-23	KNF431AS <sup>2)</sup>	4KA□ <sub>3)</sub> △•
	SOT-25	KN431AN	N4A□ <sub>3)</sub> •
	SOT-89	KN431AF	KN431A•
±0.5%	TO-92	KN431B	KN431 B•
	TO-92M	KN431BM	KN431B•
	SOT-23	KN431BS <sup>1)</sup>	4GB□ <sub>3)</sub> △•
	SOT-23	KNF431BS <sup>2)</sup>	4KB□ <sub>3)</sub> △•
	SOT-25	KN431BN	N4B□ <sub>3)</sub> •
	SOT-89	KN431BF	KN431B•
±0.3%	SOT-23	KN431CS <sup>1)</sup>	4GC□ <sub>3)</sub> △•
	SOT-23	KNF431CS <sup>2)</sup>	4KC□ <sub>3)</sub> △•

1) KN431xS Pin Connection : (1) Cathode, (2) Reference, (3) Anode

2) KNF431xS Pin Connection : (1) Reference, (2) Cathode, (3) Anode

3) □ : Year & Week Code

4) △ : Machine Code [SOT-23 PKG.]

• Da Lian

## Absolute maximum ratings

[T<sub>A</sub>=25°C]

Characteristic	Symbol	Rating	Unit
Cathode to Anode voltage	V <sub>KA</sub>	37	V
Cathode current Range (Continuous)	I <sub>K</sub>	-100~150	mA
Reference input current Range	I <sub>ref</sub>	-0.05~10	mA
Power Dissipation	SOT-23	P <sub>D</sub> (Note1)	350
	SOT-25	P <sub>D</sub> (Note1)	400
	SOT-89	P <sub>D</sub> (Note1)	500
	TO-92	P <sub>D</sub> (Note2)	700
	TO-92M	P <sub>D</sub> (Note2)	400
Junction Temperature	T <sub>J</sub>	150	°C
Operating temperature range	T <sub>opr</sub>	-40 ~ +85	°C
Storage temperature range	T <sub>stg</sub>	-55 ~ +150	°C

Note 1 : Mounted on a glass epoxy PCB board (25.4 × 25.4mm). T<sub>A</sub>=25°C

Note 2 : T<sub>A</sub>=25°C

## Recommended operating conditions

Characteristic	Symbol	Rating		Unit
		Min.	Max.	
Cathode to Anode voltage	V <sub>KA</sub>	V <sub>ref</sub>	36	V
Cathode current	I <sub>K</sub>	1	100	mA

## Electrical Characteristics (T<sub>A</sub>=25°C, unless otherwise noted.)

Characteristic	Symbol	Condition	Min.	Typ.	Max.	Unit
Reference voltage (Fig.1)	V <sub>ref</sub>	V <sub>KA</sub> =V <sub>ref</sub> , I <sub>K</sub> =10mA	KN431C	2.487	2.495	2.503
			KN431B	2.482		2.508
			KN431A	2.482		2.520
Reference input voltage deviation over temperature (Fig.1, Note1,2)	ΔV <sub>ref</sub>	V <sub>KA</sub> =V <sub>ref</sub> , I <sub>K</sub> =10mA @ -40°C ≤ T <sub>A</sub> ≤ 85°C	-	7	30	mV
Ratio of delta reference input voltage to delta cathode voltage (Fig.2)	$\frac{\Delta V_{ref}}{\Delta V_{KA}}$	I <sub>K</sub> =10mA V <sub>ref</sub> ≤ V <sub>KA</sub> ≤ 36V	-	-1.0	-2.7	mV/V
Reference current (Fig.2)	I <sub>ref</sub>	I <sub>K</sub> =10mA, R <sub>1</sub> =10KΩ, R <sub>2</sub> =∞	-	1.8	4.0	μA
Reference input current deviation over temperature (Fig.2, Note 1,2)	ΔI <sub>ref</sub>	I <sub>K</sub> =10mA, R <sub>1</sub> =10KΩ, R <sub>2</sub> =∞ @ -40°C ≤ T <sub>A</sub> ≤ 85°C	-	0.4	2.5	μA
Minimum cathode current for regulation	I <sub>K(MIN)</sub>	V <sub>KA</sub> =V <sub>ref</sub>	-	0.35	1.0	mA
Off-state cathode current (Fig.3)	I <sub>K(off)</sub>	V <sub>KA</sub> =36V, V <sub>ref</sub> =0V	-	2.7	1000	nA
Dynamic impedance (Fig.1, Note3)	Z <sub>KA</sub>	V <sub>KA</sub> =V <sub>ref</sub> , f ≤ 1.0KHz 1.0mA ≤ I <sub>K</sub> ≤ 100mA	-	0.15	0.5	Ω

Fig. 1 Test circuit for  $V_{KA}=V_{ref}$

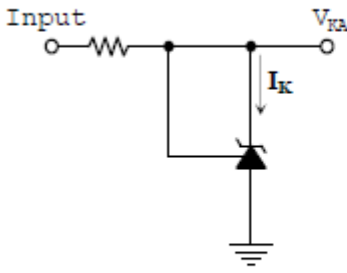

Fig. 2 Test circuit for  $V_{KA}>V_{ref}$

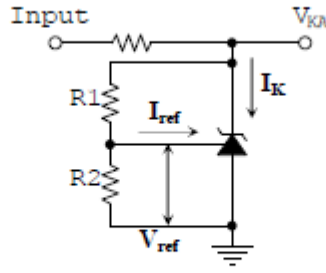
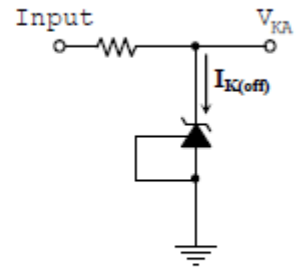

Fig. 3 Test circuit for  $I_{K(off)}$



$$V_{KA} = V_{ref} \times \left(1 + \frac{R_1}{R_2}\right) + I_{ref} \times R_1$$

Note.

1. Ambient temperature range:  $T_{Low} = -40\text{ }^\circ\text{C}$ ,  $T_{High} = 85\text{ }^\circ\text{C}$
2. The deviation parameters  $\Delta V_{ref}$  and  $\Delta I_{ref}$  are defined as the difference between the maximum value and minimum value obtained over the full operating ambient temperature range that applied.

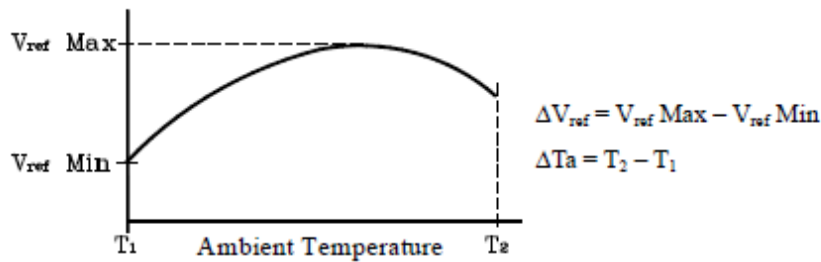

The average temperature coefficient of the reference input voltage,  $\alpha V_{ref}$  is defined as:

$$\alpha V_{ref} \left(\frac{\text{ppm}}{^\circ\text{C}}\right) = \frac{\left(\frac{\Delta V_{ref}}{V_{ref}(T_a = 25^\circ\text{C})} \times 10^6\right)}{\Delta T_a}$$

Example :  $\Delta V_{ref} = 30\text{mV}$  and the slope is positive,

$$\Delta V_{ref} @ 25^\circ\text{C} = 2.495\text{V}$$

$$\Delta T_a = 70^\circ\text{C}$$

$$\alpha V_{ref} \left(\frac{\text{ppm}}{^\circ\text{C}}\right) = \frac{\left(\frac{0.03}{2.495}\right) \times 10^6}{70} = 171\text{ppm}/^\circ\text{C}$$

3. The dynamic impedance  $Z_{KA}$  is defined as:

$$|Z_{KA}| = \frac{\Delta V_{KA}}{\Delta I_K}$$

When the device is operating with two external resistors, R1 and R2, (refer to Fig.2) the total dynamic impedance of the circuit is given by:

$$|Z_{KA}'| = |Z_{KA}| \times \left(1 + \frac{R_1}{R_2}\right)$$

Electrical Characteristic Curves

Fig.4  $V_{ref}$  vs  $T_A$

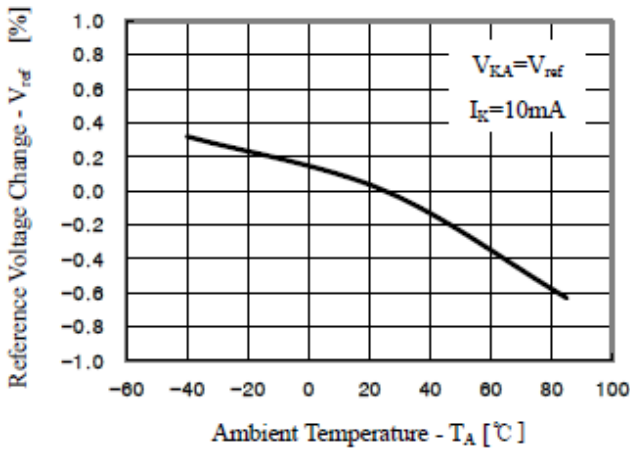

Fig.5  $I_{ref}$  vs  $T_A$

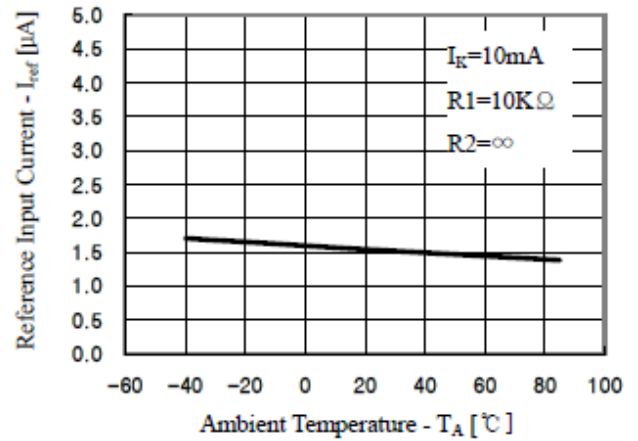

Fig.6  $I_{KA}$  vs  $V_{KA}$

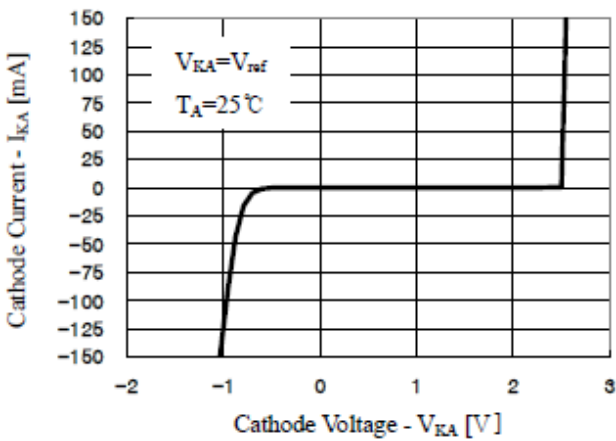

Fig.7  $I_{KA}$  vs  $V_{KA}$

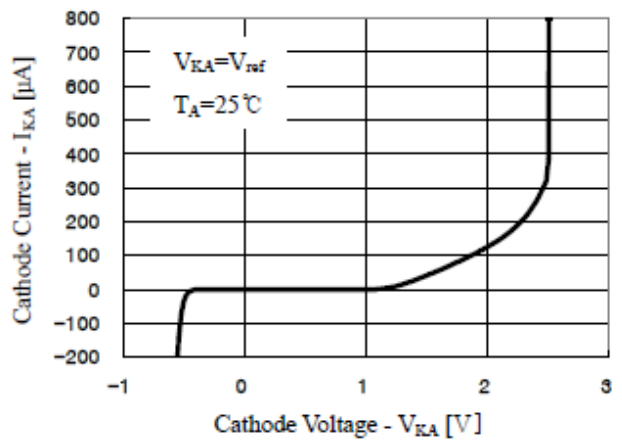

Fig.8  $I_{off}$  vs  $T_A$

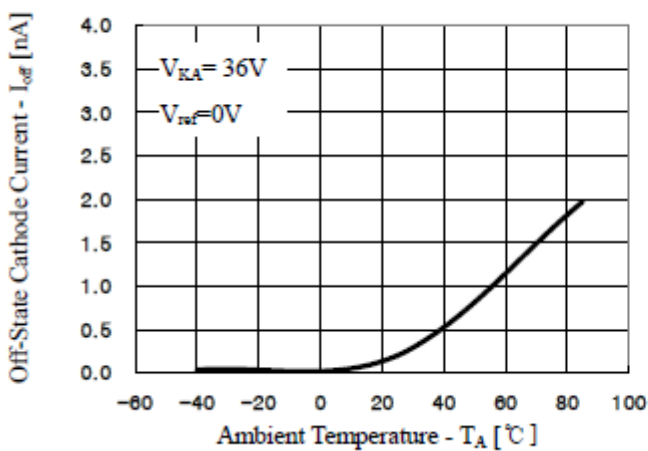
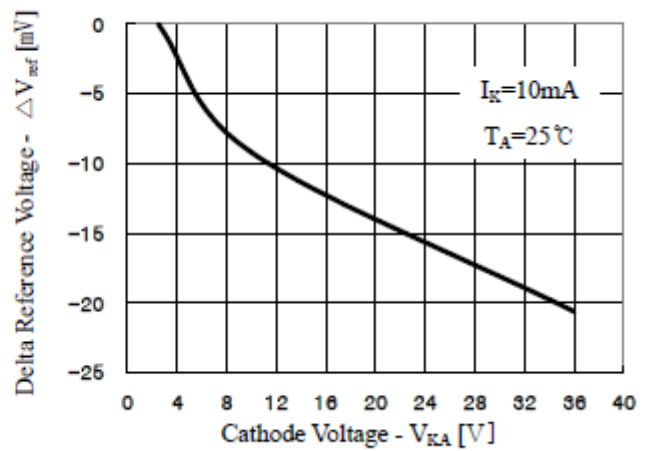
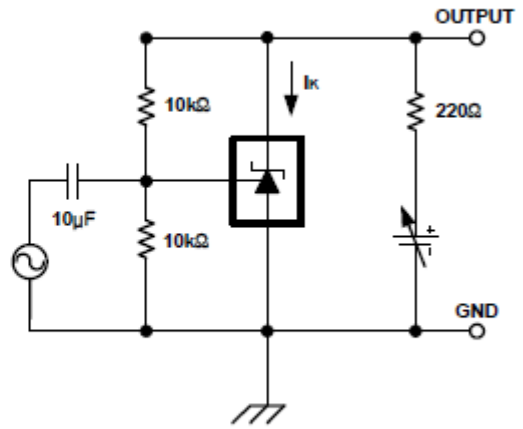
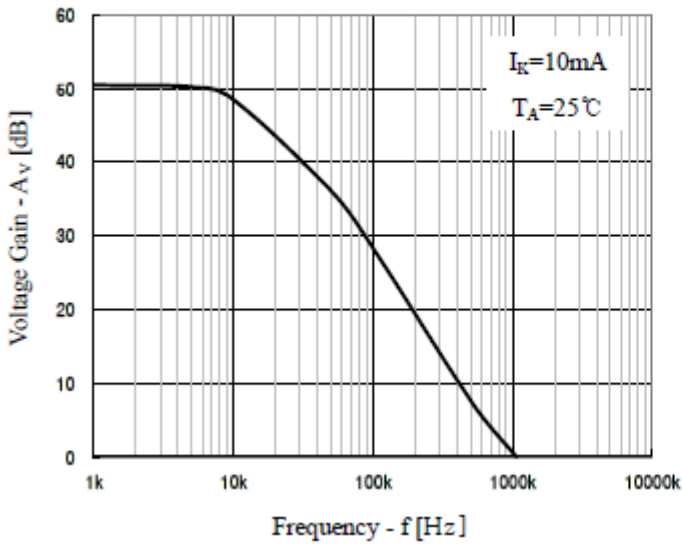

Fig.9  $\Delta V_{ref}$  vs  $V_{KA}$



Electrical Characteristic Curves

Fig.10  $A_V$  vs  $f$



Voltage Gain Test Circuit

Fig.11  $|Z_{KA}|$  vs  $f$

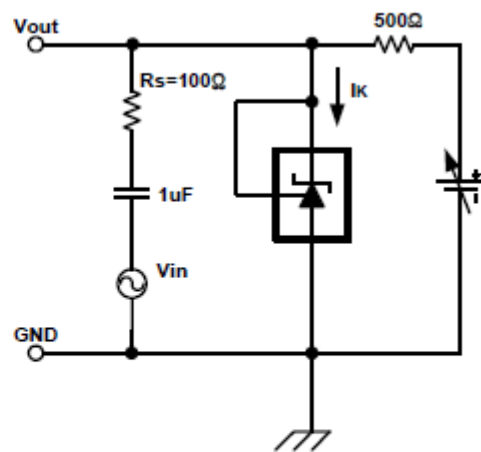
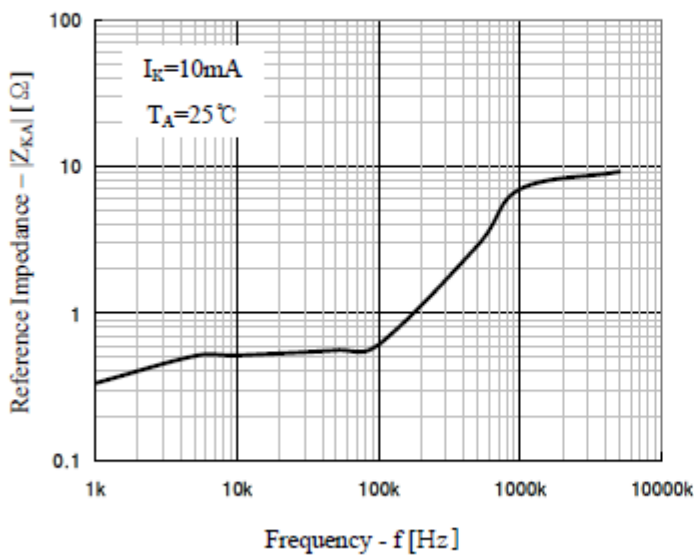

$$Z_{KA} = V_{out}/V_{in} \times R_s$$

Dynamic Impedance Test Circuit

Fig.12 Pulse Response

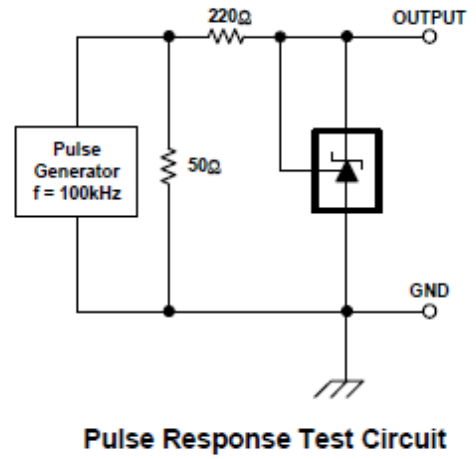
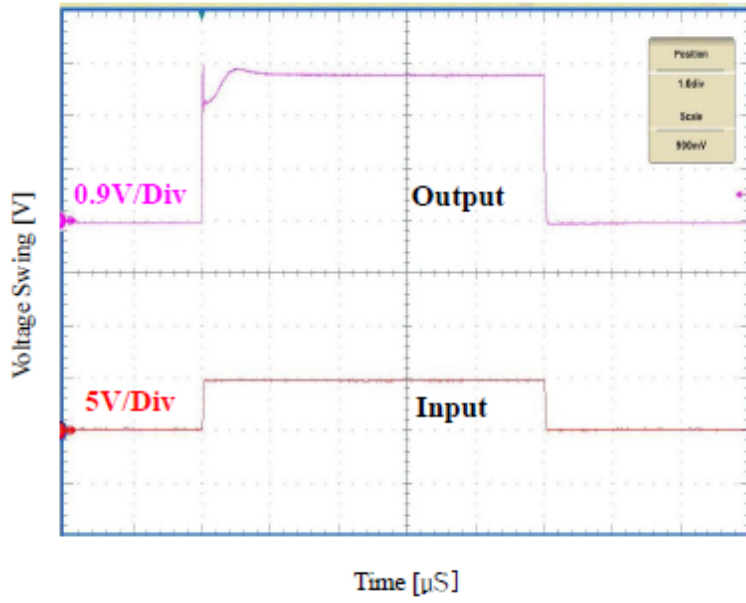

Typical Application

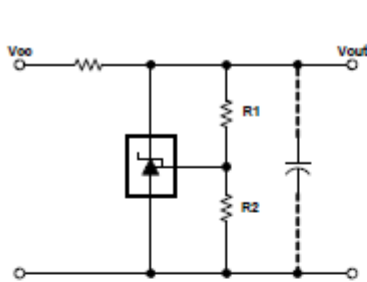

$$V_{out} = \left(1 + \frac{R1}{R2}\right) V_{ref}$$

Fig14. Shunt Regulator

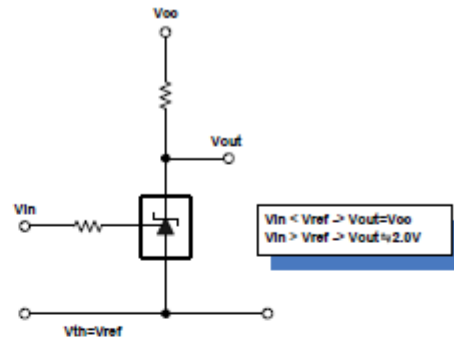
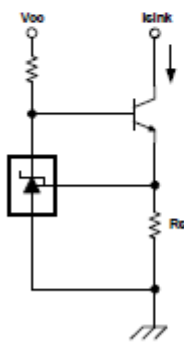
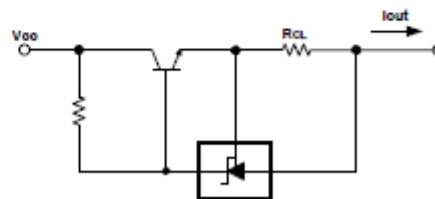

Fig15. Single-Supply Comparator with Temperature-Compensated Threshold



$$I_{sink} = V_{ref} / R_s$$

Fig16. Constant Current Sink



$$I_{out} = V_{ref} / R_{cL}$$

Fig17. Constant Current Source

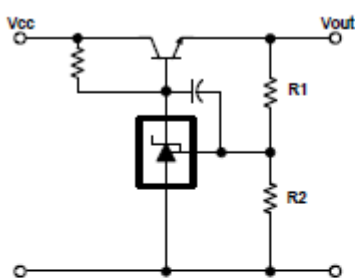

$$V_{out} = \left(1 + \frac{R1}{R2}\right) V_{ref}$$

$$V_{in(min)} = V_{out} + V_{be}$$

$$V_{out(min)} = V_{ref} + V_{be}$$

Fig18. Series Pass Regulator

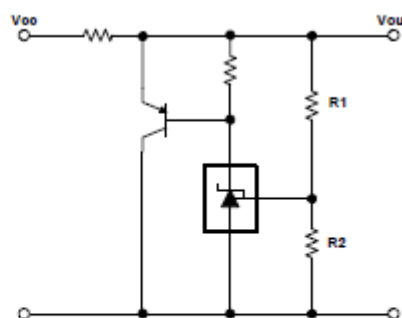

$$V_{out} = \left(1 + \frac{R1}{R2}\right) V_{ref}$$

Fig19. High Current Shunt Regulator



## SOT-89 Outline Dimension (Unit: mm)

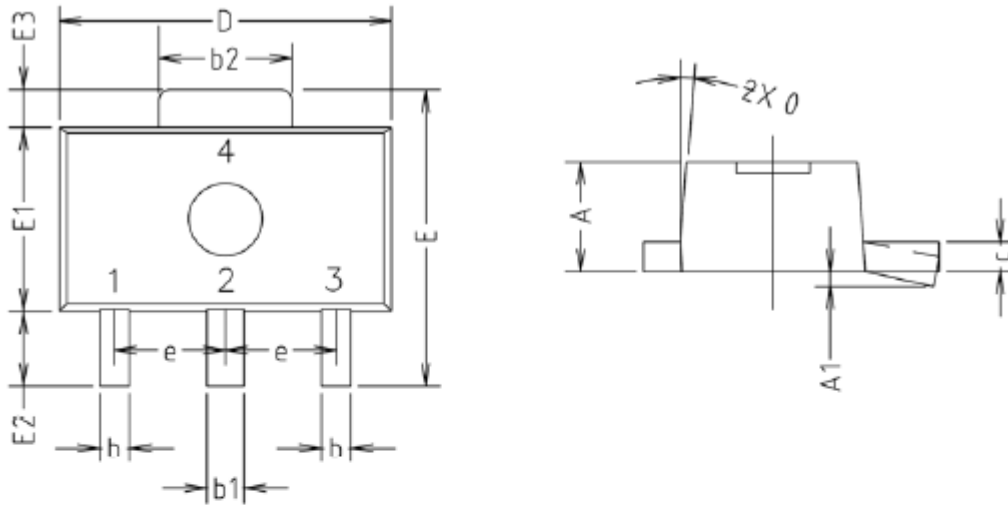

SYMBOL	MILLIMETERS			NOTE
	MINIMUM	NOMINAL	MAXIMUM	
A	1.40	1.50	1.60	
A1	0.00	-	0.10	
b	0.38	0.42	0.48	
b1	0.48	0.52	0.58	
b2	1.79	1.82	1.87	
c	0.40	0.42	0.46	
D	4.40	4.50	4.70	
E	3.70	4.00	4.30	
E1	2.40	2.50	2.70	
E2	0.80	1.00	1.20	
E3	0.40	0.50	0.60	
e	1.50 TYP.			
φ	4° TYP.			

### ※ Recommend PCB solder land (Unit: mm)

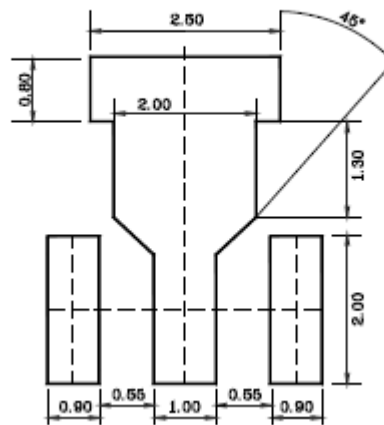

## SOT-23 Outline Dimension (Unit: mm)

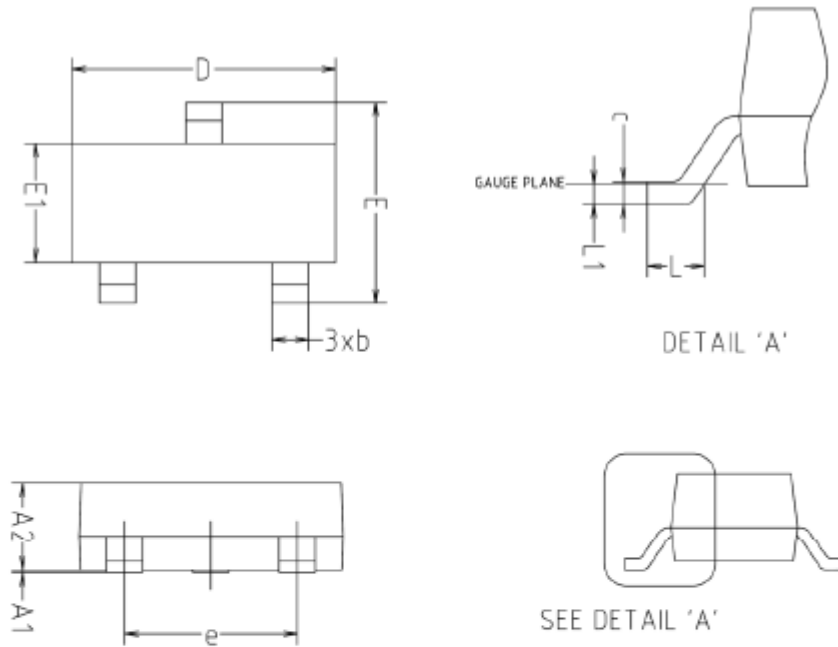

SYMBOL	MILLIMETERS			NOTE
	MINIMUM	NOMINAL	MAXIMUM	
A1	0.00	-	0.10	
A2	0.82	-	1.02	
b	0.39	0.42	0.45	
c	0.09	0.12	0.15	
D	2.80	2.90	3.00	
E	2.20	2.40	2.60	
E1	1.20	1.30	1.40	
e	1.90BSC			
L	0.20	-	-	
L1	0.12BSC			

## ※ Recommend PCB solder land (Unit: mm)

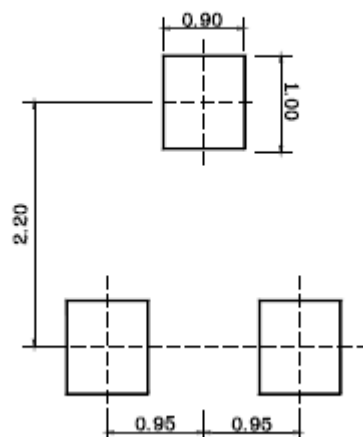

SOT-25 Outline Dimension (Unit: mm)

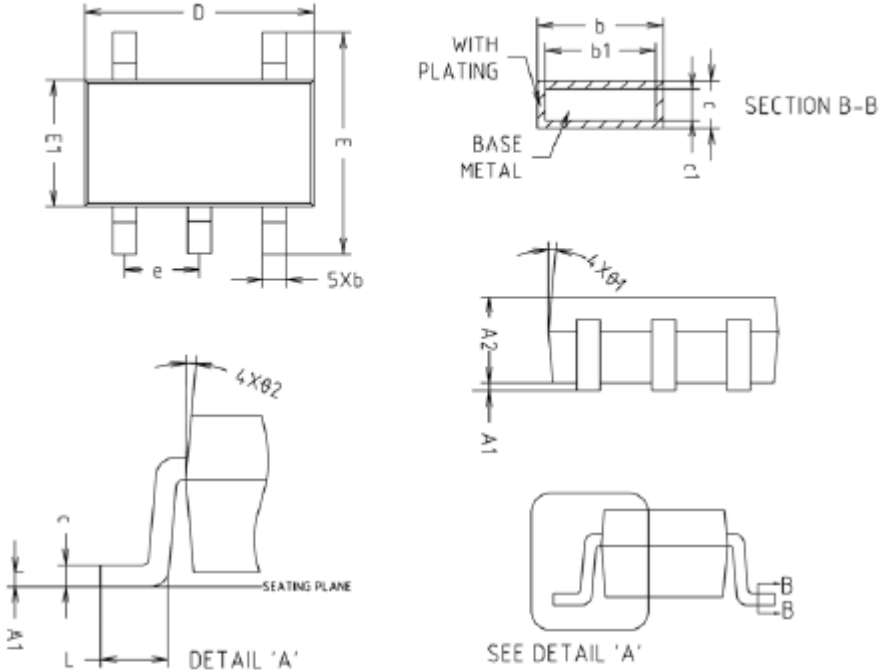

SYMBOL	MILLIMETERS			NOTE
	MINIMUM	NOMINAL	MAXIMUM	
A1	0.000	0.050	0.100	
A2	1.000	1.100	1.200	
b	-	0.400	0.450	
b1	-	0.375	0.425	
c	0.110	0.150	0.190	
c1	0.085	0.125	0.165	
D	2.800	2.900	3.000	
E	2.600	2.800	3.000	
E1	1.500	1.600	1.700	
e	0.930	0.950	0.970	
L	0.400	-	-	
Ø1	5° REF			
Ø2	5° REF			

※ Recommend PCB solder land (Unit: mm)

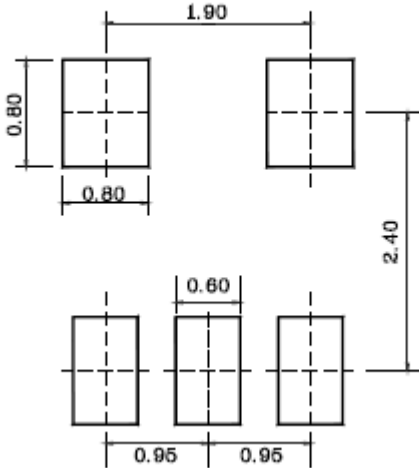

## TO-92 Outline Dimension (Unit: mm)

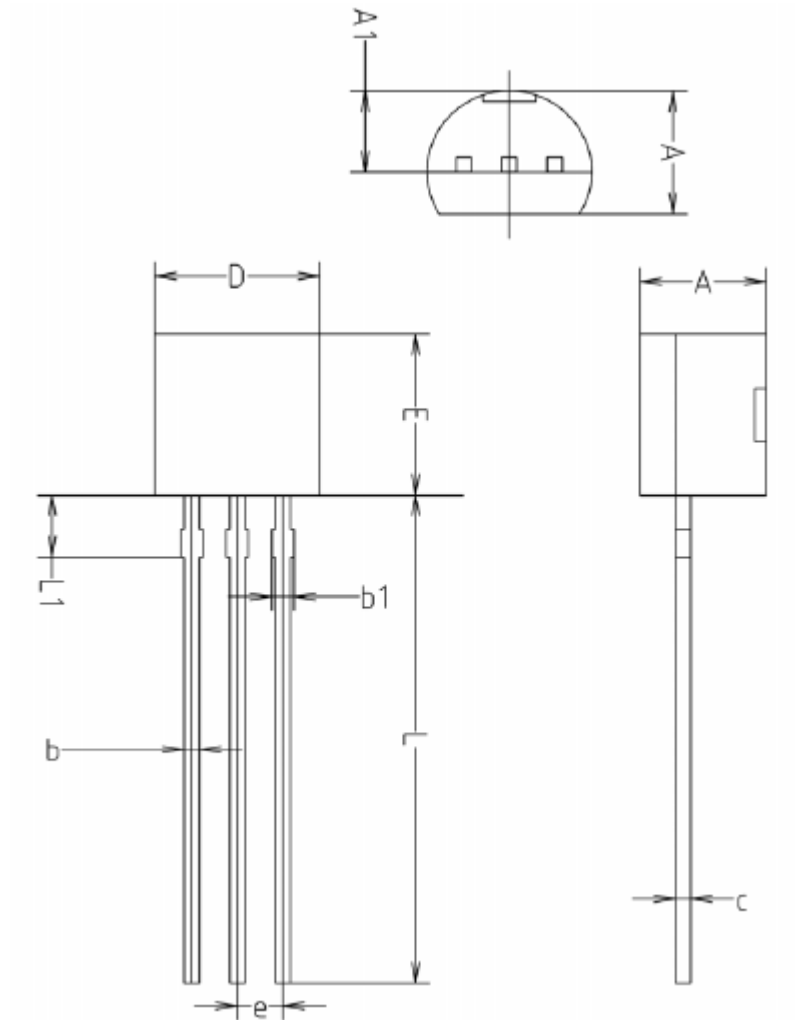

SYMBOL	MILLMETERS(mm)		
	MINIMUM	NOMINAL	MAXIMUM
A	3.40	3.50	3.66
A1	2.46	2.51	2.59
b	0.39	0.44	0.53
b1	0.39	-	0.63
c	0.35	0.42	0.47
D	4.48	4.60	4.70
E	4.48	4.60	4.70
e	1.17	1.27	1.37
L	13.70	14.00	14.77
L1	1.55	1.70	2.15

TO-92M Outline Dimension (Unit: mm)

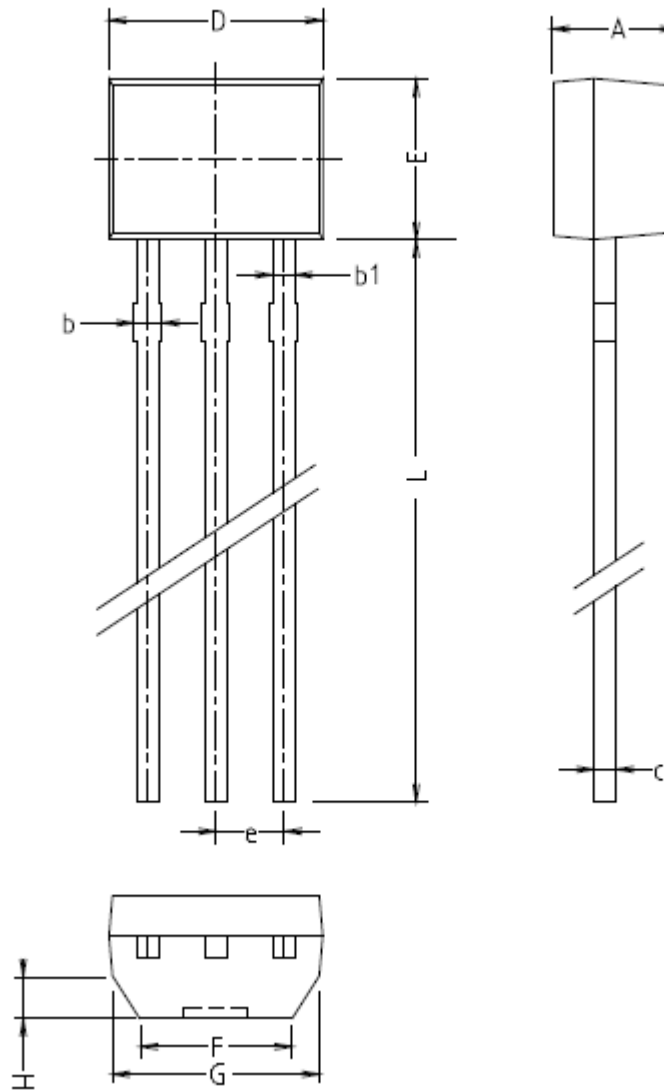

SYMBOL	MILLMETERS(mm)		
	MINIMUM	NOMINAL	MAXIMUM
A	2.20	2.30	2.40
b	—	0.50	—
b1	—	0.44	—
c	—	0.42	—
D	3.90	4.00	4.10
E	2.90	3.00	3.10
e	—	1.27	—
L	—	14.50	15.00
F	2.80	2.85	2.90
G	3.80	—	—
H	—	0.70	—

**The AUK Dalian Corp. products are intended for the use as components in general electronic equipment (Office and communication equipment, measuring equipment, home appliance, etc.).**

**Please make sure that you consult with us before you use these AUK Dalian Corp. products in equipments which require high quality and / or reliability, and in equipments which could have major impact to the welfare of human life(atomic energy control, airplane, spaceship, transportation, combustion control, all types of safety device, etc.). AUK Dalian Corp. cannot accept liability to any damage which may occur in case these AUK Dalian Corp. products were used in the mentioned equipments without prior consultation with AUK Dalian Corp..**

**Specifications mentioned in this publication are subject to change without notice.**

## X-ON Electronics

Largest Supplier of Electrical and Electronic Components

*Click to view similar products for [Voltage References](#) category:*

*Click to view products by [Kodenshi](#) manufacturer:*

Other Similar products are found below :

[622664A](#) [636116E](#) [748389C](#) [AS431ARTR-E1](#) [NCP431BCSNT1G](#) [NCP432BCSNT1G](#) [NCV431BSNT1G](#) [AP4313UKTR-G1](#)  
[TL1431AIYDT](#) [AZ431BR-ATRE1](#) [622668D](#) [NCP432BVSNT1G](#) [5962-8686103XC](#) [NCV431BVDMR2G](#) [AZ432BNTR-G1](#)  
[AP4306BUKTR-G1](#) [SC431BVSNT1G](#) [MAX6023EBT30+T](#) [NCV431ASNT1G](#) [LM4040CEM3-5.0/V+T](#) [LT1460KCS3-3#TRM](#)  
[LT1460KCS3-3.3#TRM](#) [LT1019AIS8-2.5](#) [LT6660KCDC-10#TRMPBF](#) [LTC6652BHLS8-5#PBF](#) [LTC6652AHLS8-4.096#PBF](#)  
[LTC6655BHLS8-4.096#PBF](#) [LT6660HCDC-5#TRMPBF](#) [LM336Z-2.5#PBF](#) [LT1021BMH-10](#) [SC431ILPRAG](#) [TLVH431MIL3T](#)  
[MAX6023EBT21+T](#) [AP432AQG-7](#) [ADR4540CRZ](#) [LM4040B25QFTA](#) [TS3325AQPR](#) [REF102AU/2K5](#) [TL4050B25QDBZR](#)  
[TL4051C12QDCKR](#) [TL431ACZ](#) [KA431SLMF2TF](#) [KA431SMF2TF](#) [KA431SMFTF](#) [LM385BXZ/NOPB](#) [LM4040QCEM3-3.0/NOPB](#)  
[LM4041C12ILPR](#) [LM4050AEM3X-5.0/NOPB](#) [LM4050AIM3X-5.0/NOPB](#) [LM4120AIM5-2.5/NOP](#)