

SPECIFICATION FOR APPROVAL

CUSTOMER:

CUSTOMER' S PART NO. :

DESCRIPTION:

QUANTITY:

PART NO.: AFBR091628-08

DATE: 2016.06.30

REMARK:

CUSTOMER SIGNATURE

APPROVED BY	DRAWN BY
Tywin Yin	Candice Yang/Hannah Zhou

*Samples meet RoHS and
Lead-free requirement*

KOHER

KOHER (Shanghai) Electronic Co.,Ltd



SPECIFICATION FOR APPROVAL

CUSTOMER		PART NO.	AFBR091628-08
Cus.'s PART NO.		PAGE NO	2 of 3
DESCRIPTION		DATE	2016.06.30

1. Features

- Ferrite core made of NiZn, a material which works in a broadband frequency range
- Many different types and grades of material (NiZn) for the best possible interference suppression
- Operating temperature: $-25\text{ }^{\circ}\text{C}$ up to $+125\text{ }^{\circ}\text{C}$

2. Applications

- Wires, Wire-wrapping cables
- Coaxial cables
- Multiconductor wires
- Cable e.g. of power supplies, data and gage signal lines

3. Dimensions(in mm)

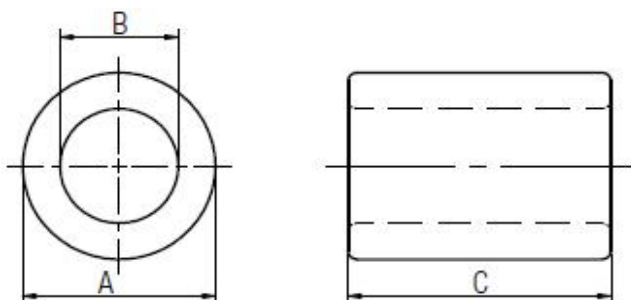



SPECIFICATION FOR APPROVAL

CUSTOMER		PART NO.	AFBR091628-08
Cus.'s PART NO.		PAGE NO.	3 of 3
DESCRIPTION		DATE	2016.06.30

4. Specification

Part Number	A (mm)	B (mm)	C (mm)	Z @ 25 MHz (Ω) 1 Turn	Z @ 100 MHz (Ω) 1 Turn	Z @ 25 MHz (Ω) 2 Turns	Z @ 100 MHz (Ω) 2 Turns	Cable Ø (mm)
AFBR091628-08	16.0	9.0	28.0	133	217	544	705	≤ 8.6

Note:

- Storage Temperature (before assembly): -20°C to +60°C
- Operating Temperature: -25°C to +125°C
- Test conditions of Electrical Properties: 20°C, 33% RH, if not specified differently

5. Typical Performance Curves

AFBR091628-08

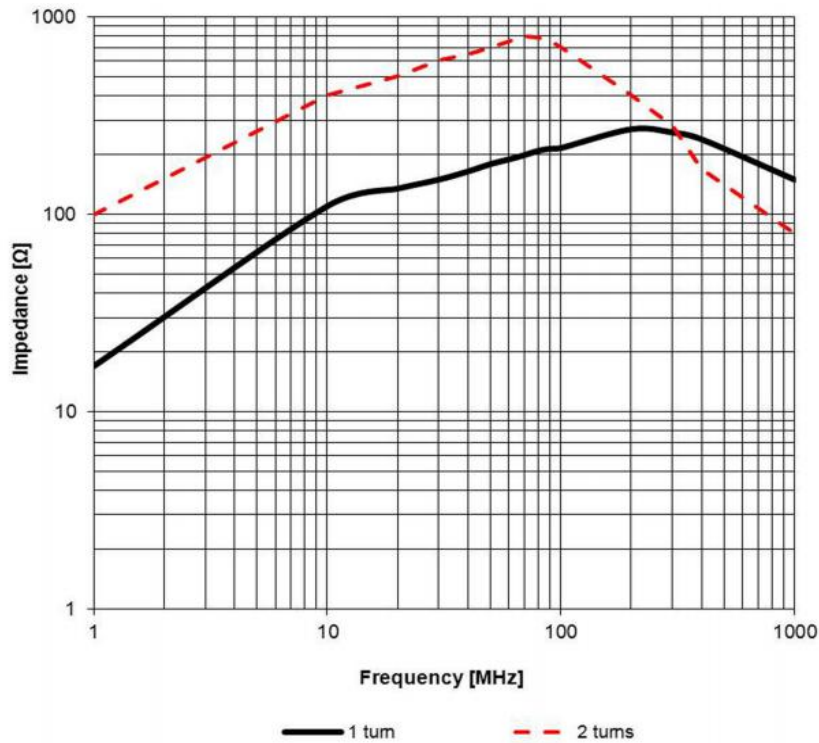

X-ON Electronics

Largest Supplier of Electrical and Electronic Components

Click to view similar products for [Ferrite Clamp On Cores](#) category:

Click to view products by [KOHER](#) manufacturer:

Other Similar products are found below :

[CS28B0984](#) [CS28B1501](#) [CV28B1642](#) [RA33B4340](#) [IL25B0642K](#) [SA28B0121](#) [SS33B2033](#) [HI28B2039](#) [RA33B2480](#) [TC28B0937](#)
[AS28B2031](#) [432703037561](#) [USB28B2034](#) [432202209491](#) [4327 018 21641](#) [CF28B0642](#) [CF28B1937](#) [SS20B2037](#) [SS33B2032](#) [SS25B2032](#)
[SS20B2034](#) [PM28B0686](#) [RA20B1729](#) [CS33B4000](#) [TC33B0805](#) [SS33B2040](#) [TC28B1501](#) [AS33B2036](#) [AS25B2032](#) [TC28B0550](#)
[AS25B2036](#) [AS28B2027](#) [F9 SCRC 35B](#) [SHKJ 1325 0330A](#) [SHKJ 3615-2830D](#) [SHKJ 2035-0930A](#) [SHKJ 1325 0530A](#) [SHKJ 2020-0830B](#)
[SHKJ 2132-1130](#) [SHKJ 2040-0730C](#) [SHKJ 1730-0730A](#) [TFBR162820-15](#) [AFBR081629-07](#) [AFBR091628-08](#) [SHKJ 2017-0830B](#) [SHKJ](#)
[1518-0730](#) [SHKJ 3035-1330](#) [SHKJ 1833-6530F](#) [SHKJ 2032-0930](#) [SHKJ 2916-1530B](#)