

COMe-mEL10 (E2)

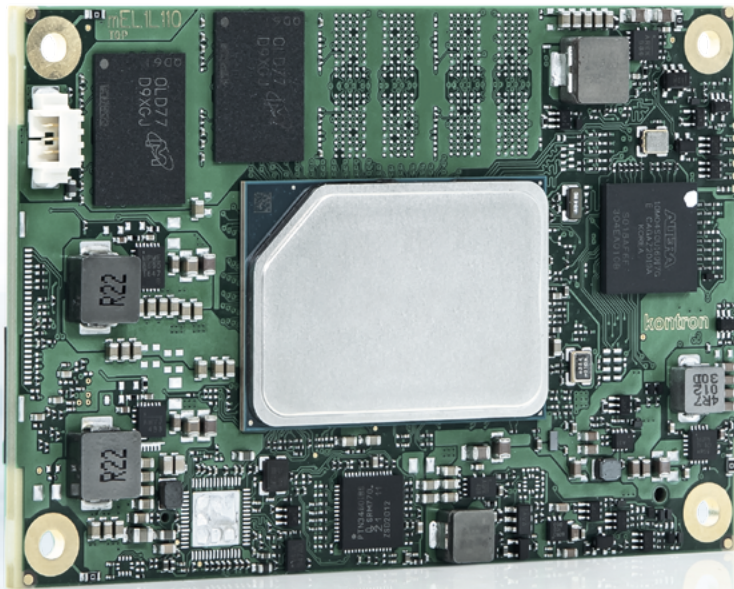

COM Express® mini Type 10 with Intel Atom® x6000E, Pentium® and Celeron® Series

- ▶ Low-Power – Performance/Watt optimized form factor solution
- ▶ Up to 16 GByte LPDDR4 memory down (In-Band ECC)
- ▶ 2x USB 3.1/2.0, 6x USB 2.0, USB client optional, 2x SATA, eMMC Flash
- ▶ 1 GbE (optional 2.5 GbE) with TSN support
- ▶ Industrial grade temperature

POSSIBILITIES START HERE

► TECHNICAL INFORMATION

COMPLIANCE	COM Express® mini, Pin-out Type 10
DIMENSIONS (H x W)	84 x 55 mm
CPU	Intel Atom® x6000E Series, Pentium® and Celeron® Processors For details see table (CPU variants) given below
CHIPSET	-
MAIN MEMORY	Up to 16 GByte LPDDR4-4267 memory down (In-Band ECC)
GRAPHICS CONTROLLER	SOC: Intel® HD Gfx Gen11: LVDS/eDP, 1x DP++, up to 4K
ETHERNET CONTROLLER	SOC + LAN PHY GPHY115 (GPHY215 on request) + 2x optional as SGMII instead of SATA
ETHERNET	1 GBit Ethernet (2.5 GBit on request with GPHY215) + 2x optional 2.5 GBit
STORAGE	2x SATA 6Gb/s, SDIO Interface (shared with GPIO)
FLASH ONBOARD	eMMC option – up to 128 GByte eMMC MLC
PCI EXPRESS®	PCIe Gen 3.0 - PCIe lane configurations: 4 x1, 2 x1 + 1 x2, 2 x2
DISPLAY	DDI: DP++, LVDS: Single Channel 18/24 bit or eDP 1.3
USB	2x USB 3.1 (incl. USB 2.0) + 6x USB 2.0, Port 7 is dual role (Client/Host)
SERIAL	2x serial interface (RX/TX only), optional CAN
AUDIO	Intel® High Definition Audio
OTHER FEATURES	SPI, LPC, SMB, Fast I ² C, Staged Watchdog, RTC
SPECIAL FEATURES	Industrial grade temperature
FEATURES ON REQUEST	eMMC Flash configuration (up to 64 GByte pSLC, up to 128 GByte MLC) eDP instead of LVDS General Purpose SPI instead of Boot SPI USB client, Trusted Platform Module TPM 2.0, de-populated LAN PHY
POWER MANAGEMENT	ACPI 6.0
POWER SUPPLY	4.75 V – 20 V Wide Range, Single Supply Power
BIOS	AMI Aptio V
OPERATING SYSTEM	Windows® 10, Linux, VxWorks
TEMPERATURE	COMe-mEL10- commercial temperature: 0 °C to +60 °C operating, -30 °C to +85 °C non-operating COMe-mEL10 E2 - industrial temperature: -40 °C to +85 °C operating, -40 °C to +85 °C non-operating
HUMIDITY	93 % relative Humidity at 40 °C, non-condensing (according to IEC 60068-2-78)

CPU VARIANTS

BRAND	PROCESSOR NUMBER	TDP	CORES	THREADS	CACHE	BASE FREQ	MAX TURBO FREQ	GRAPHICS GEN 11	ECC	PREMIUM IO	FUNCTIONAL SAFETY CERTIFIED	USE CONDITION
Intel® Celeron® Processor	J6413	10 W	4	4	1.5 MByte	1.8 GHz	3.0 GHz	16 EU	no	Intel® PSE	no	PC Client
Intel® Pentium® Processor	J6426	10 W	4	4	1.5 MByte	2.0 GHz	3.0 GHz	32 EU	no	Intel® PSE	no	PC Client
Intel® Celeron® Processor	N6211	6.5 W	2	2	1.5 MByte	1.2 GHz	3.0 GHz	16 EU	no	Intel® PSE	no	PC Client
Intel® Pentium® Processor	N6415	6.5 W	4	4	1.5 MByte	1.2 GHz	3.0 GHz	16 EU	no	Intel® PSE	no	PC Client
Intel Atom® processor	x6211E	6 W	2	2	1.5 MByte	1.3 GHz	3.0 GHz	16 EU	Yes– In Band	Intel® PSE	no	Embedded
Intel Atom® processor	x6413E	9 W	4	4	1.5 MByte	1.5 GHz	3.0 GHz	16 EU	Yes– In Band	Intel® PSE	no	Embedded
Intel Atom® processor	x6425E	12 W	4	4	1.5 MByte	2.0 GHz	3.0 GHz	32 EU	Yes– In Band	Intel® PSE	no	Embedded
Intel Atom® processor	x6212RE	6 W	2	2	1.5 MByte	1.2 GHz	n/a	16 EU	Yes– In Band	Intel® PSE, Intel® TCC	no	Industrial
Intel Atom® processor	x6414RE	9 W	4	4	1.5 MByte	1.5 GHz	n/a	16 EU	Yes– In Band	Intel® PSE, Intel® TCC	no	Industrial
Intel Atom® processor	x6425RE	12 W	4	4	1.5 MByte	1.9 GHz	n/a	32 EU	Yes– In Band	Intel® PSE, Intel® TCC	no	Industrial

BLOCK DIAGRAM

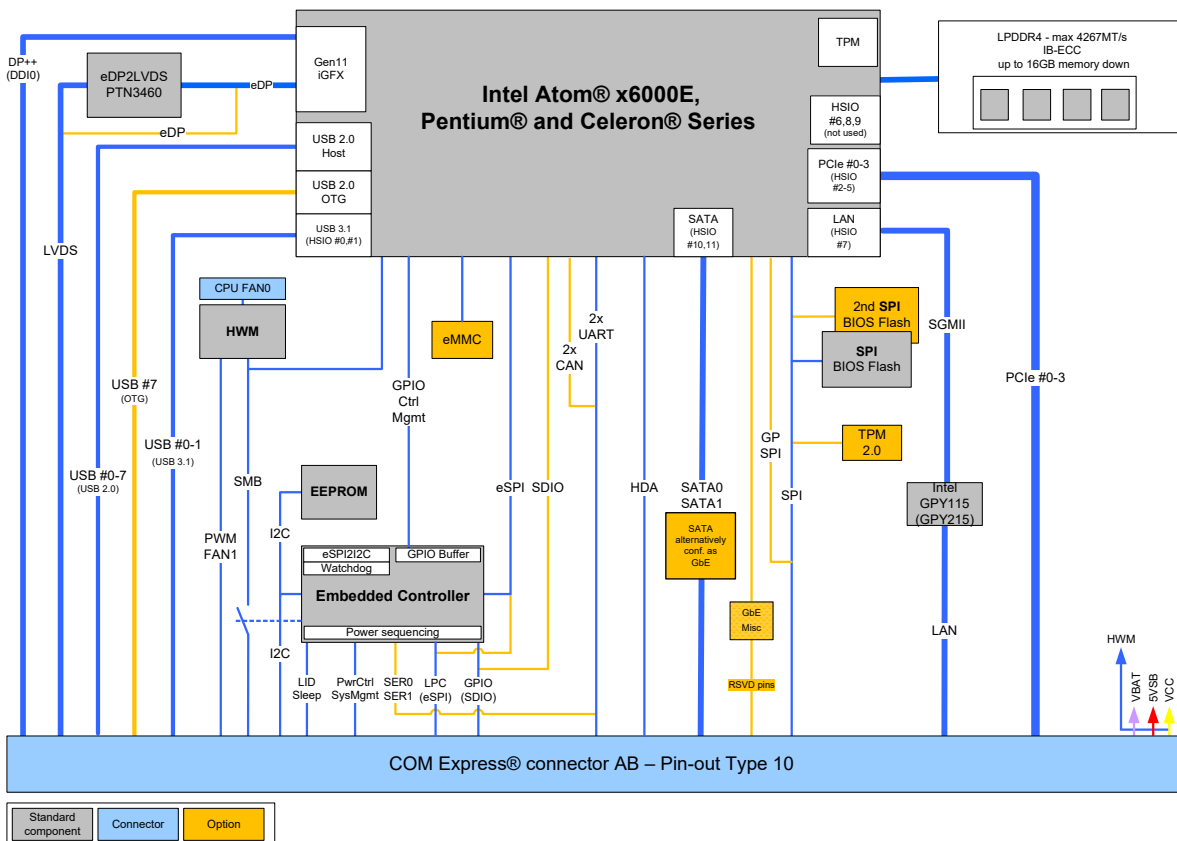

▶ VARIANTS

PART NO.	CPU	MEMORY	ETH PHY (1 GbE OR 2.5 GbE)	FLASH - eMMC	VARIOUS	OP. TEMPERATURE
34012-0416-N1-2	N6211	4 GByte, 3200 MT/s	1 GbE	16 GByte MLC	LPC, LVDS	0 °C - 60 °C
34012-0432-J2-4	J6426	4 GByte, 3733 MT/s	1 GbE	32 GByte MLC	LPC, LVDS	0 °C - 60 °C
34013-0416-R1-2	x6212RE	4 GByte, 3200 MT/s	1 GbE	16 GByte MLC	LPC, LVDS	-40 °C - 85 °C
34013-0432-R1-4	x6414RE	4 GByte, 3200 MT/s	1 GbE	32 GByte MLC	LPC, LVDS	-40 °C - 85 °C
34013-0832-R2-4	x6425RE	8 GByte, 4267 MT/s	1 GbE	32 GByte MLC	LPC, LVDS	-40 °C - 85 °C

Please contact your sales representative for other versions.

▶ CARRIER

ARTICLE	PART NO.	DESCRIPTION
COME EVAL CARRIER T10 GEN2	34101-0000-00-2	COM Express® Eval Carrier Type 10 Gen 2
COME REFCARRIER-I T10 TNIP	34105-0000-00-0	COM Express® Reference Carrier-i Type 10 Thin-nanoITX Professional

▶ COOLING

ARTICLE	PART NO.	DESCRIPTION
HSP COMe-mEL10 (E2) THREAD	34013-0000-99-0	Heatspreader for COMe-mEL10 commercial and E2, threaded mounting holes
HSP COMe-mEL10 (E2) THROUGH	34013-0000-99-1	Heatspreader for COMe-mEL10 commercial and E2, through holes
HSP COMe-mEL10 (E2) SLIM THREAD	34013-0000-99-2	Heatspreader for Slimline 6.5 mm for COMe-mEL10 commercial and E2, threaded mounting holes
HSP COMe-mEL10 (E2) SLIM THROUGH	34013-0000-99-3	Heatspreader for Slimline 6.5 mm for COMe-mEL10 commercial and E2, through holes

▶ GLOBAL HEADQUARTERS

Kontron Europe GmbH

Gutenbergstraße 2
85737 Ismaning, Germany
Tel.: +49 821 4086-0
Fax: +49 821 4086-111
info@kontron.com

www.kontron.com

X-ON Electronics

Largest Supplier of Electrical and Electronic Components

Click to view similar products for [Heat Sinks](#) category:

Click to view products by [Kontron](#) manufacturer:

Other Similar products are found below :

[657-20ABPNE](#) [73452PPBA](#) [A22-4026](#) [120-1873-007](#) [218-40CTE3](#) [231-69PAB-15V](#) [231-75PAB-13V](#) [231-75PAB-15V](#) [253-122ABE-22](#)
[PSC22CB](#) [295-2](#) [CLP212SG](#) [D10100-28](#) [BDN183CBA01](#) [3-21053-4](#) [TX0506-1B](#) [LAE66A3CB](#) [511-3U](#) [73381PPBA](#) [73403PPBA](#) [8191-](#)
[E40](#) [510-12M](#) [529802B00000](#) [D10650-40T5](#) [6225B-MT6G](#) [ATS-54310K-C2-R0](#) [648-51AB](#) [657-20ABPESC](#) [679-25AG](#) [FK 212 CB SA](#)
[FK225 SA L1](#) [241404B91203G](#) [6801G](#) [680-5K](#) [7106DG/TR](#) [SK145 37 5STSTO220](#) [7109DG/TR](#) [TS-11042-CY](#) [S14K35G3S5](#) [8924G](#)
[7717-133DAP](#) [7717-26DAP](#) [4509](#) [SW25-4G](#) [CLP-215](#) [CLP-207](#) [D20850-40-T2](#) [APF30-30-10CB/A01](#) [V8508E](#) [268-85CTE](#)