



Diodes type D64 are of modern design with internal spring loaded contacts, high alumina ceramic insulator and pressure welded encapsulation. Designed for use in power electronic circuits and equipment under normal operating conditions.

KEY PARAMETERS

U_{RRM}	up to 3200 V
$I_{F(AV)}$	250 A
I_{FSM}	5500 A

FEATURES

- all diffused design
- high current capabilities
- high surge current capabilities
- high rates voltages
- low thermal impedance
- tested according to IEC standards
- compact size and small weight

APPLICATION

- High Voltage Power Supplies
- Motor Control
- Battery Chargers
- Free Wheeling Diode
- Resistance Welding

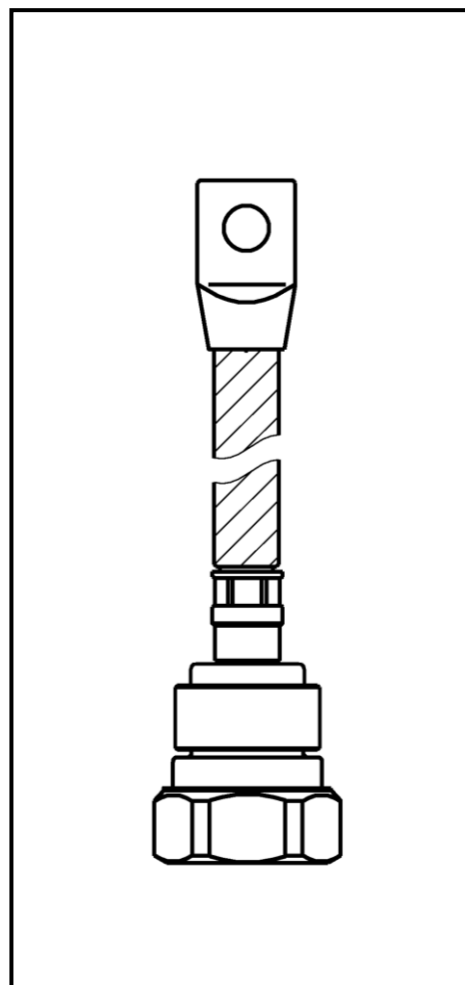

See package details for further information

Designed for use in high power industrial and commercial power electronic circuits and equipment where high currents are encountered and high reliability is essential.

D64-250

Diode



KKD64250, October 2006 version

ORDERING INFORMATION

When ordering please refer to device code builder presented below.
Please use the complete part number when ordering, quote or in any future correspondence relating to your order.

D61-250-□□-□0

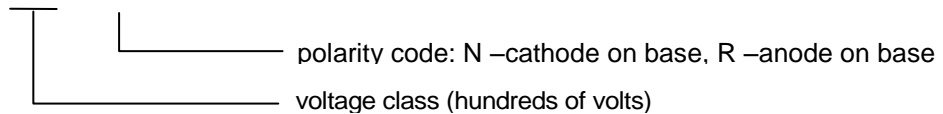

ELECTRICAL PARAMETERS

Voltage ratings

Voltage class	U_{RRM}	U_{RSM}	I_{RRM}
	V	V	mA
18	1800	1900	50
20	2000	2100	
22	2200	2300	
24	2400	2500	
26	2600	2700	
28	2800	2900	
30	3000	3100	
32	3200	3300	

Zakłady Elektronowe LAMINA S.A.
Puławska 34
PL-05-500 Piaseczno
POLAND

Tel.: +48-22-7572731
Tel.: +48-22-3989409
Fax.: +48-22-3989407
e-mail: sekretariat@lamina.com.pl
www.lamina.com.pl

D64-250

Diode

KKD64250, October 2006 version

Electrical properties

Parameter		Unit	Test conditions	Value
Average forward current @ case temperature	$I_{F(AV)}$	A		250
	T_c	°C		125
RMS forward current	$I_{F(RMS)}$	A		395
Surge current	I_{FSM}	A	$T_j=T_{jmax}$, $U_R=0,8U_{RRM}$, $t_p=10ms$	5500
I^2t – value	I^2t	kA^2s		150
Forward voltage drop max.	U_{FM}	V	$T_j=25^\circ C$, $I_{FM}=800A$	1,60
Threshold voltage	$U_{F(T0)}$	V		0,70
Slope resistance	r_F	$m\Omega$		1,22

Thermal properties

Parameter		Unit	Test conditions	Value
Thermal resistance, junction to case	R_{thJC}	°C/W	DC	0,12
Thermal resistance, case to heatsink	R_{thCS}	°C/W		0,10
Operating junction temperature	$T_{jmin} \dots T_{jmax}$	°C		-40...+175
Storage temperature	T_{stg}	°C		-40...+175

Mechanical properties

Parameter		Unit	Value
Mounting force	F	kN	3,5
Weight	m	g	180

D64-250

Diode

KKD64250, October 2006 version

Package details

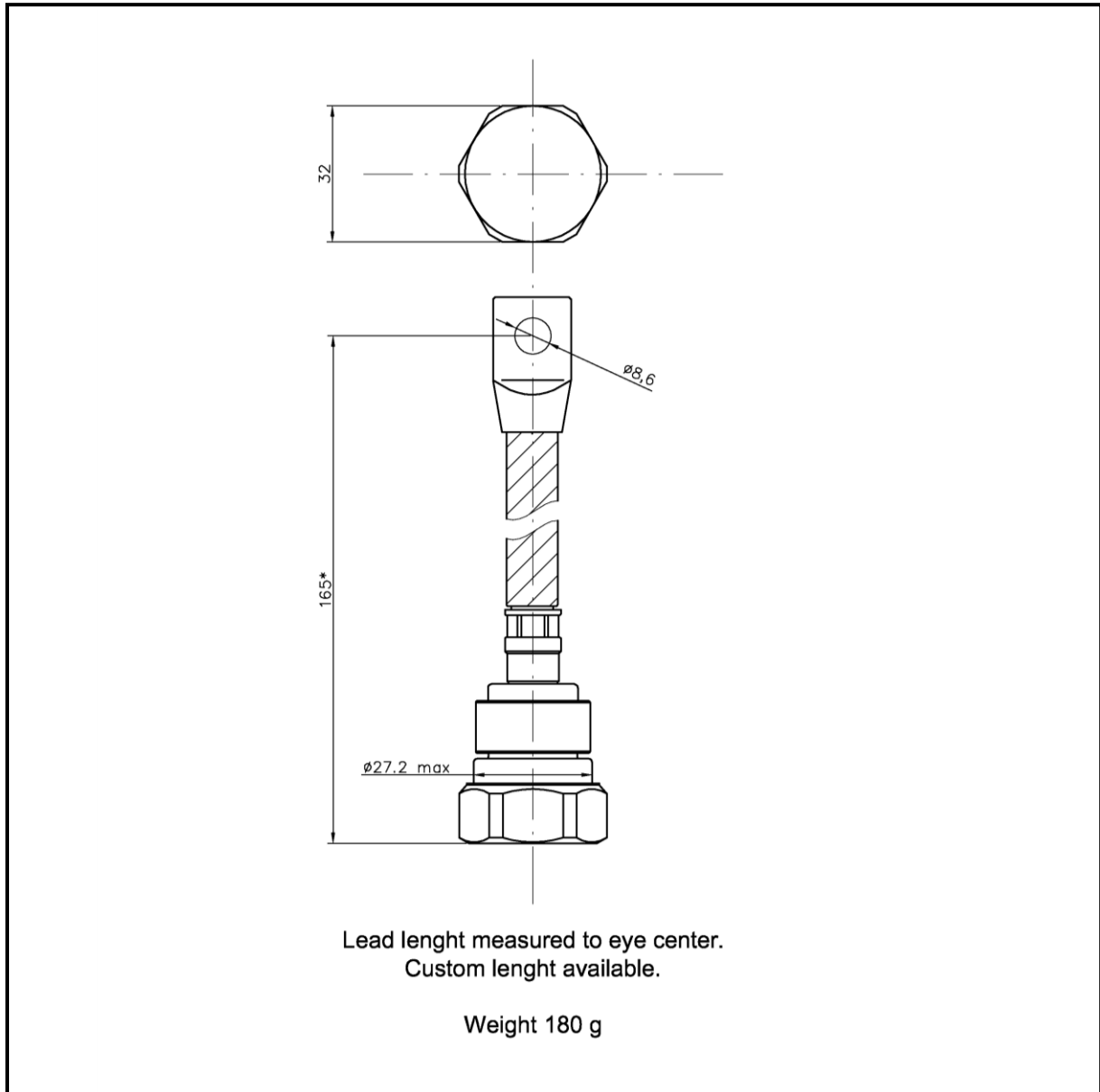

For further package information, please contact Sales & Marketing Department. All dimensions in mm, unless stated otherwise.
Do not scale.

Zakłady Elektronowe LAMINA S.A.
Puławska 34
PL-05-500 Piaseczno
POLAND

Tel.: +48-22-7572731
Tel.: +48-22-3989409
Fax.: +48-22-3989407
e-mail: sekretariat@lamina.com.pl
www.lamina.com.pl

D64-250

Diode



Zakłady Elektronowe
LAMINA S.A.

KKD64250, October 2006 version

CHARACTERISTICS

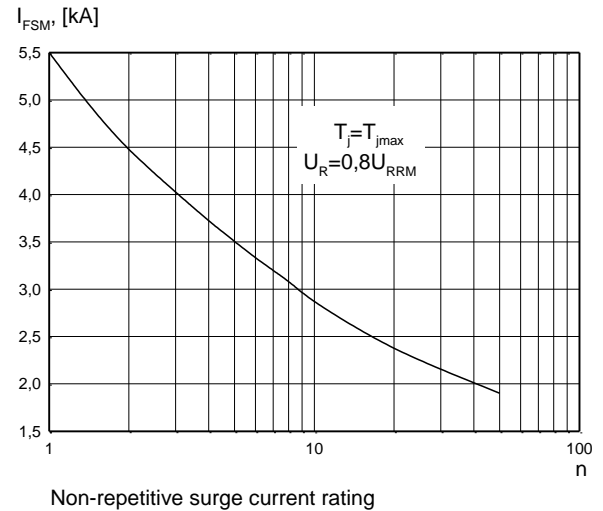
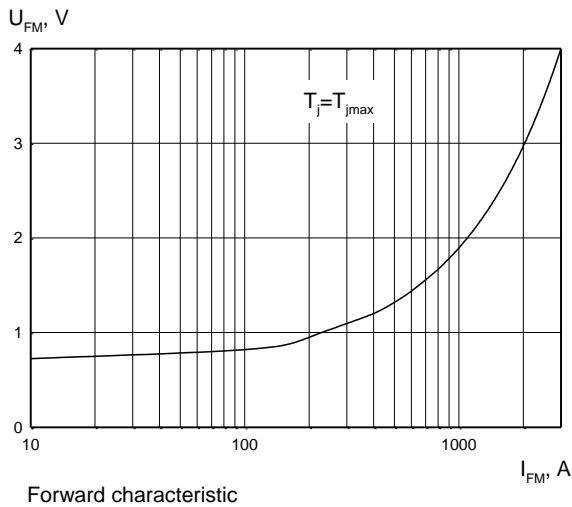
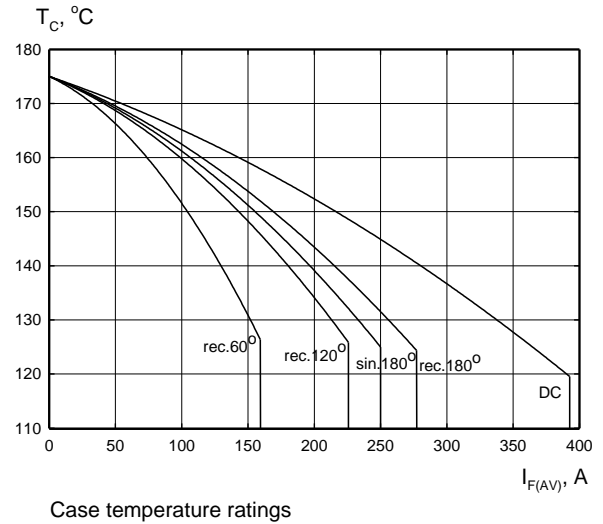
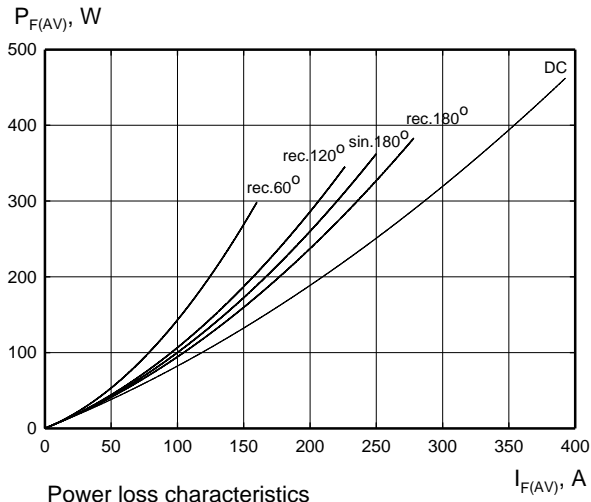

Zakłady Elektronowe LAMINA S.A.
Puławska 34
PL-05-500 Piaseczno
POLAND

Tel.: +48-22-7572731
Tel.: +48-22-3989409
Fax.: +48-22-3989407
e-mail: sekretariat@lamina.com.pl
www.lamina.com.pl

D64-250

Diode

KKD64250, October 2006 version

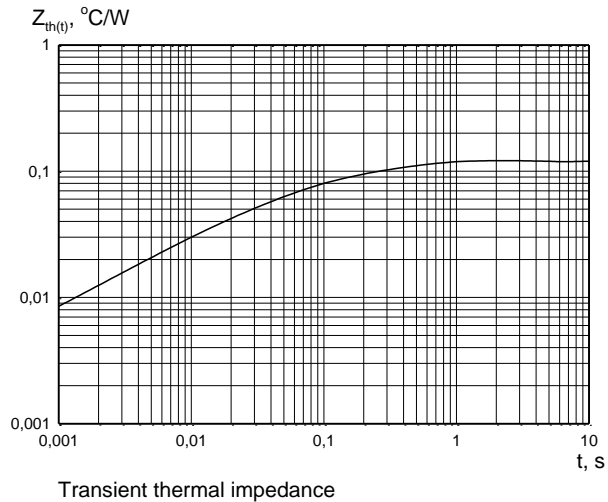

HEATSINKS

LAMINA S.I. has its own proprietary range of extruded aluminium heatsinks designed to optimise the performance of our semiconductors with natural and forced air flow.

POWER ASSEMBLY CAPABILITY

LAMINA S.I. provides a support for those customers requiring more than a basic semiconductor and offers precisely assembled Power Blocks according to factory or customer standards.

X-ON Electronics

Largest Supplier of Electrical and Electronic Components

Click to view similar products for [Rectifiers](#) category:

Click to view products by [KUBARA LAMINA](#) manufacturer:

Other Similar products are found below :

[70HFR40](#) [RL252-TP](#) [1N5397](#) [NTE5841](#) [NTE6038](#) [SCF5000](#) [1N4002G](#) [1N4005-TR](#) [JANS1N6640US](#) [481235F](#) [RRE02VS6SGTR](#) [067907F](#)
[MS306](#) [70HF40](#) [US2JFL-TP](#) [A1N5404G-G](#) [CRS04\(T5L,TEMQ\)](#) [ACGRA4007-HF](#) [ACGRB207-HF](#) [CLH03\(TE16L,Q\)](#) [ACGRC307-HF](#)
[ACEFC304-HF](#) [NTE6356](#) [NTE6359](#) [NTE6002](#) [NTE6023](#) [NTE6039](#) [NTE6077](#) [85HFR60](#) [40HFR60](#) [1N1186RA](#) [70HF120](#) [85HFR80](#)
[D126A45C](#) [SCF7500](#) [D251N08B](#) [SCHJ22.5K](#) [SM100](#) [SCPA2](#) [SDHD5K](#) [VS-12FL100S10](#) [ACGRA4001-HF](#) [D1821SH45T PR](#) [D1251S45T](#)
[NTE5990](#) [NTE6358](#) [NTE6162](#) [NTE5850](#) [SKN20/08](#) [SKN300/16](#)