

Diode type D83 are of modern design with pressure contacts, high alumina ceramic insulator and cold-welding encapsulation. Designed for use in power rectifying circuits and equipment under normal operating conditions.

## KEY PARAMETERS

$U_{RRM}$	<b>up to 4400 V</b>
$I_{F(AV)}$	<b>1000 A</b>
$I_{FSM}$	<b>11400 A</b>

## FEATURES

- all diffused design
- high current capabilities
- high surge current capabilities
- high rated voltages
- low thermal impedance
- tested according to IEC standards
- compact size and small weight

## APPLICATION

- High Voltage Power Supplies
- Motor Control
- Battery Chargers
- Free Wheeling Diode
- Resistance Welding

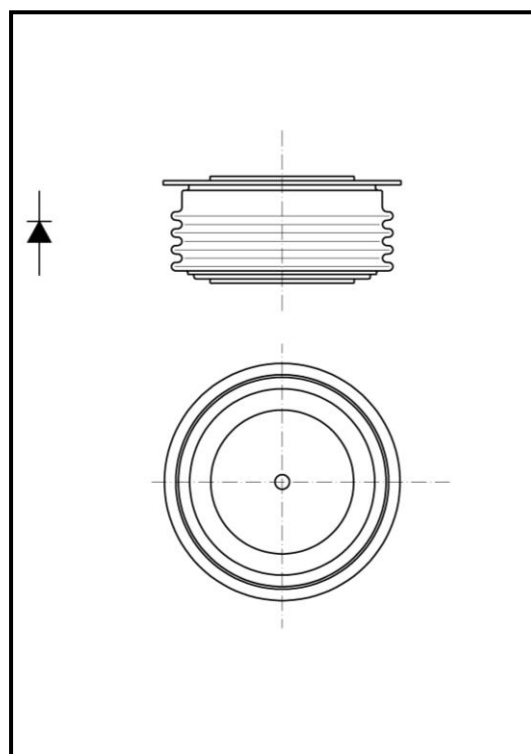

**Outline type code: JEDEC DO-200AB**  
 See Package Details for further information

Designed for use in high power industrial and commercial electronic circuits and equipment where high currents are encountered and high reliability is essential. Low forward voltages let minimize energy loss.

## ORDERING INFORMATION

When ordering please refer to device code builder presented below.  
Please use the complete part number when ordering, quote or in any future correspondence relating to your order.

**D83-1000-□□**

 voltage class (hundreds of volts)

# D83-1000

## Diode

KKD831000, July 2005 version

### ELECTRICAL PARAMETERS

#### Voltage ratings

Voltage class	$U_{RRM}$	$U_{RSM}$	$I_{RRM}$
	V	V	mA
34	3400	3500	50
36	3600	3700	
38	3800	3900	
40	4000	4100	
42	4200	4300	
44	4400	4500	

#### Electrical properties

Parameter	Unit	Test conditions	Value
Average forward current @ case temperature	$I_{F(AV)}$	A	1000
	$T_c$	°C	80
RMS forward current	$I_{F(RMS)}$	A	1570
Surge current	$I_{FSM}$	A	$T_j=175^\circ\text{C}$ , $U_R=0,8U_{RRM}$ , $t_p=10\text{ms}$
$I^2t$ – value	$I^2t$	$\text{kA}^2\text{s}$	650
Forward voltage drop max.	$U_{FM}$	V	$T_j=25^\circ\text{C}$ , $I_{FM}=1500\text{A}$
Threshold voltage	$U_{F(T0)}$	V	0,87
Slope resistance	$r_F$	$\text{m}\Omega$	0,73
Reverse recovery charge	$Q_r$	$\mu\text{C}$	$T_j=25^\circ\text{C}$ , $I_{FM}=1500\text{A}$ , $di_R/dt=25\text{A}/\mu\text{s}$

#### Thermal properties

Parameter	Unit	Test conditions	Value
Thermal resistance, junction to case	$R_{thJC}$	°C/W	two sided, DC
Thermal resistance, case to heatsink	$R_{thCS}$	°C/W	two sided
Operating junction temperature	$T_{jmin} \dots T_{jmax}$	°C	-40...+175
Storage temperature	$T_{stg}$	°C	-40...+175

**Zakłady Elektroniczne LAMINA S.A.**  
Puławska 34  
PL-05-500 Piaseczno  
POLAND

Tel.: +48-22-7572731  
Tel.: +48-22-3989409  
Fax.: +48-22-3989407  
e-mail: sekretariat@lamina.com.pl  
www.lamina.com.pl

# D83-1000

## Diode

KKD831000, July 2005 version

### Mechanical properties

Parameter		Unit	Value
Clamping force	$F_M$	kN	12,0 ... 14,0
Weight	m	g	260

### Package details

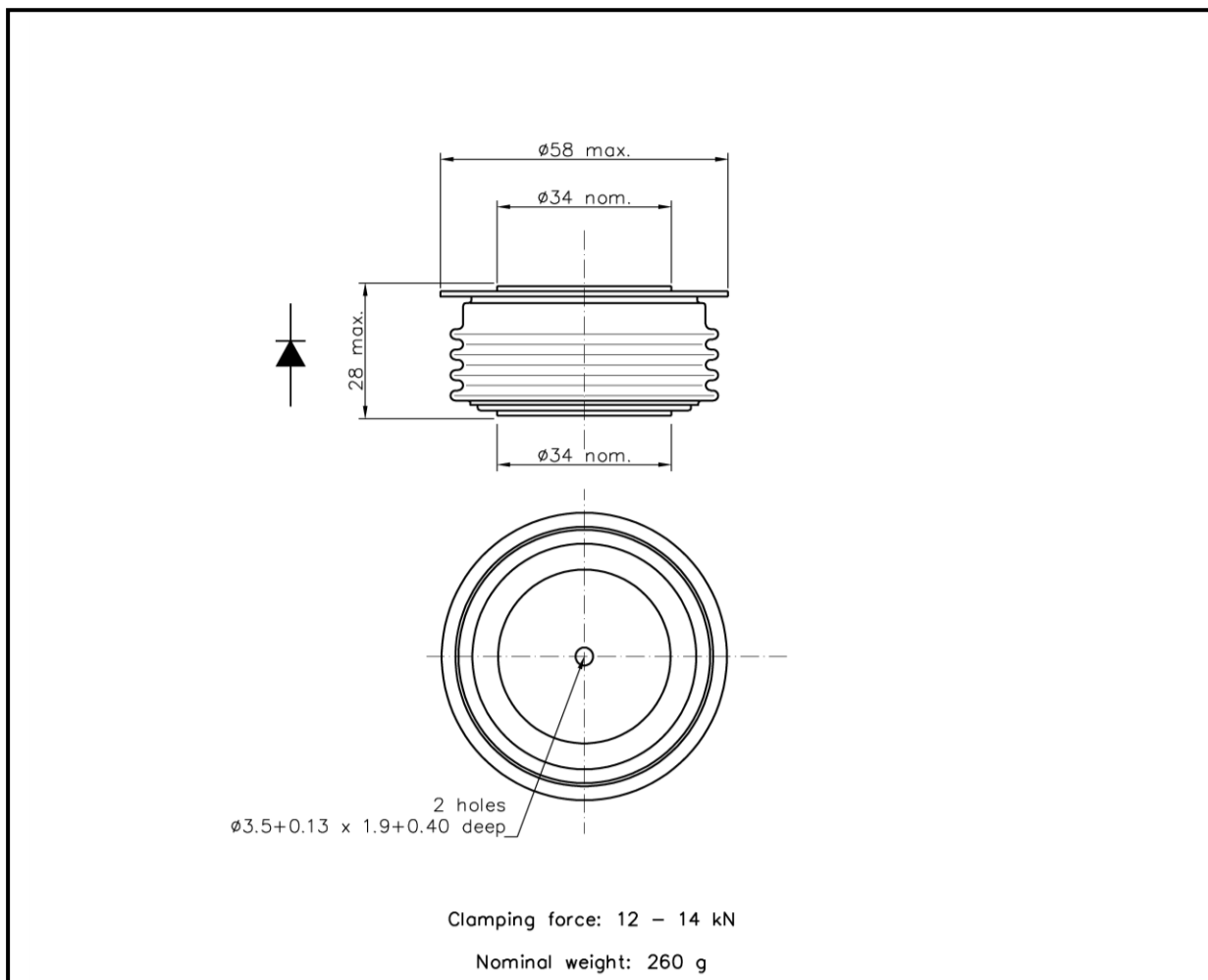

For further package information, please contact Sales & Marketing Department. All dimensions in mm, unless stated otherwise.  
Do not scale.

**Zakłady Elektronowe LAMINA S.A.**  
Puławska 34  
PL-05-500 Piaseczno  
POLAND

Tel.: +48-22-7572731  
Tel.: +48-22-3989409  
Fax.: +48-22-3989407  
e-mail: sekretariat@lamina.com.pl  
www.lamina.com.pl

# D83-1000

## Diode



Zakłady Elektronowe  
**LAMINA S.A.**

KKD831000, July 2005 version

### CHARACTERISTICS

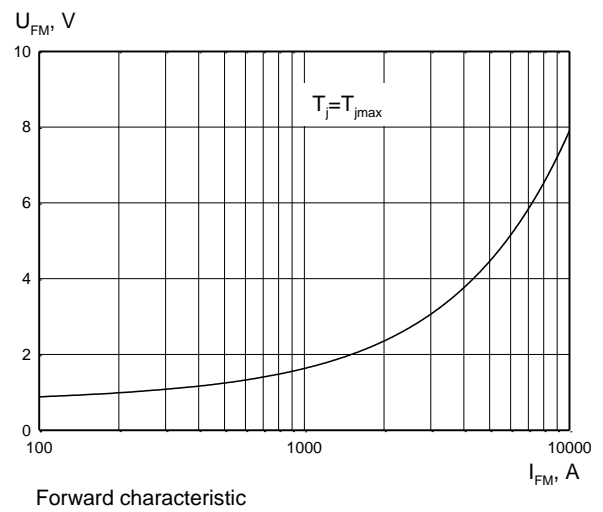
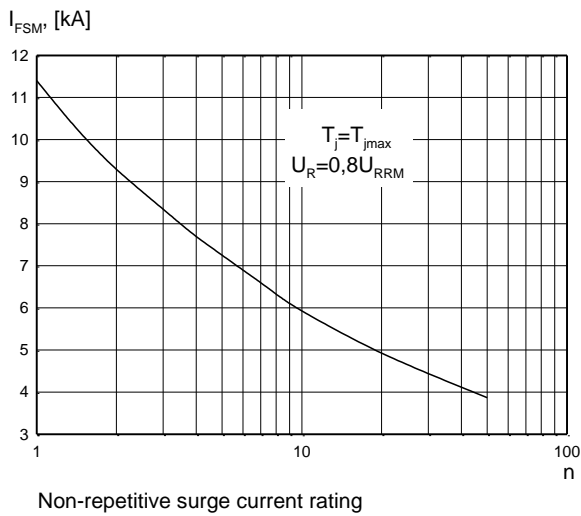
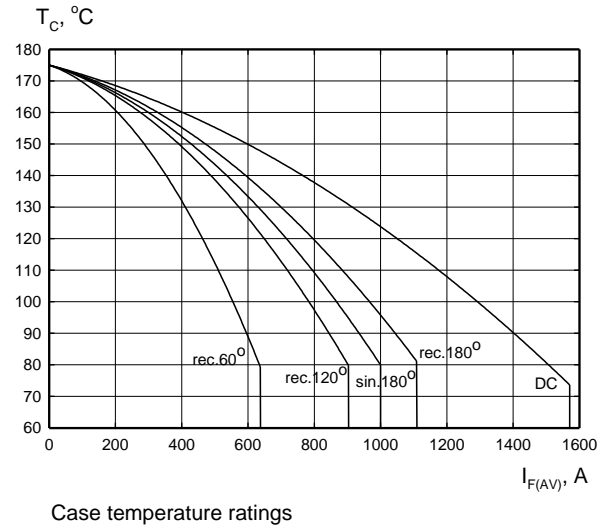
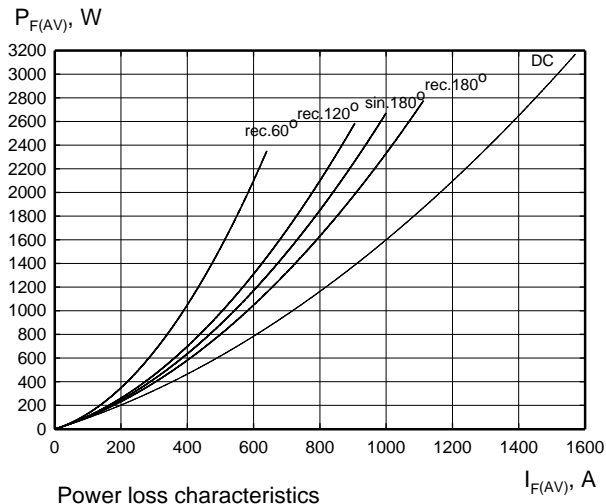

**Zakłady Elektronowe LAMINA S.A.**  
Puławska 34  
PL-05-500 Piaseczno  
POLAND

Tel.: +48-22-7572731  
Tel.: +48-22-3989409  
Fax.: +48-22-3989407  
e-mail: sekretariat@lamina.com.pl  
www.lamina.com.pl

# D83-1000

## Diode

KKD831000, July 2005 version

---

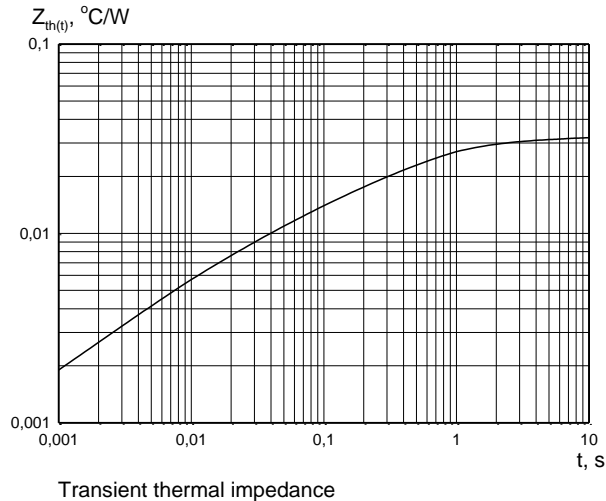

## HEATSINKS

LAMINA S.I. has its own proprietary range of extruded aluminium heatsinks designed to optimise the performance of our semiconductors with natural and forced air flow. High efficiency water cooled copper heatsinks are also available.

## DEVICE CLAMPS

Disc devices require the correct clamping force to ensure their best operation. LAMINA S.I. offers a wide selection of clamps to suit all of our manufactured devices.

## POWER ASSEMBLY CAPABILITY

LAMINA S.I. provides a support for those customers requiring more than a basic semiconductor and offers precisely assembled Power Blocks according to factory or customer standards.

## X-ON Electronics

Largest Supplier of Electrical and Electronic Components

*Click to view similar products for [Rectifiers](#) category:*

*Click to view products by [KUBARA LAMINA](#) manufacturer:*

Other Similar products are found below :

[70HFR40](#) [RL252-TP](#) [1N5397](#) [NTE5841](#) [NTE6038](#) [SCF5000](#) [1N4002G](#) [1N4005-TR](#) [JANS1N6640US](#) [481235F](#) [RRE02VS6SGTR](#) [067907F](#)  
[MS306](#) [70HF40](#) [US2JFL-TP](#) [A1N5404G-G](#) [CRS04\(T5L,TEMQ\)](#) [ACGRA4007-HF](#) [ACGRB207-HF](#) [CLH03\(TE16L,Q\)](#) [ACGRC307-HF](#)  
[ACEFC304-HF](#) [NTE6356](#) [NTE6359](#) [NTE6002](#) [NTE6023](#) [NTE6039](#) [NTE6077](#) [85HFR60](#) [40HFR60](#) [1N1186RA](#) [70HF120](#) [85HFR80](#)  
[D126A45C](#) [SCF7500](#) [D251N08B](#) [SCHJ22.5K](#) [SM100](#) [SCPA2](#) [SDHD5K](#) [VS-12FL100S10](#) [ACGRA4001-HF](#) [D1821SH45T PR](#) [D1251S45T](#)  
[NTE5990](#) [NTE6358](#) [NTE6162](#) [NTE5850](#) [SKN20/08](#) [SKN300/16](#)