

9159-800 DUAL ENTRY CARD EDGE CONNECTOR

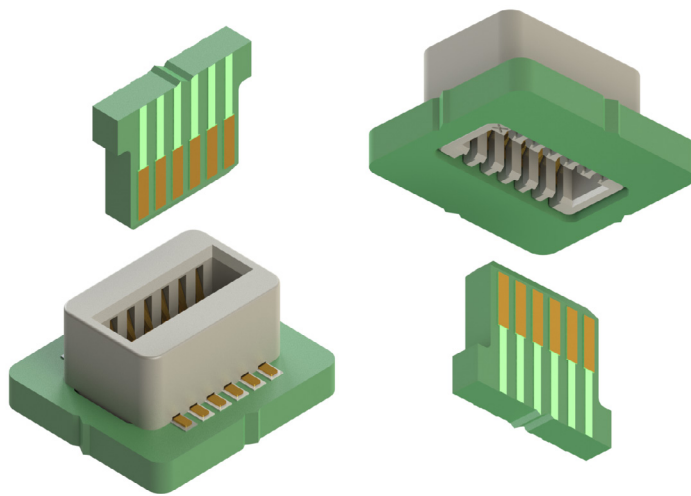

General Information



KYOCERA AVX Interconnect continues to expand its card edge product offering with the 9159-800 series of Dual Entry Card Edge Connectors, utilizing our company's field proven spring contact technology.

KYOCERA AVX's 9159-800 series of card edge connectors is a dual entry mating solution featuring a reduced pitch of 1mm with gold plated beryllium copper compression contacts. This results in a highly reliable, small form factor, vertical card edge connector. This unique design allows connection of the mating board from either side of the board (top or bottom entry).

The 9159-800 series is available from 4 to 20 positions, rated up to 2.0A per contact, and is designed for mating PCB boards with 1.6mm thickness and gold-plated pads.

APPLICATIONS

- Automotive body electronics & infotainment
- Transportation
- Industrial & factory automation (sensor, light curtain, etc.)
- Home automation
- White goods
- Product Specification: Refer to 201-01-247
- Application Notes: Refer to 201-01-248

FEATURES AND BENEFITS

- Unique vertical card edge solution capable of mating from both sides
- Excellent electrical and mechanical performance provides high integrity connections in harsh environments
- Small form factor, vertical card edge
- Recessed thru board PCB mounting for lower profile
- Easy installation with low mating forces

ELECTRICAL

- Current Rating: See table below
- Voltage Rating: 150VAC (RMS) or DC Equivalent

Positions	Current (Amps)
4-8	2.0
10-14	1.7
16-20	1.4

ENVIRONMENTAL

- Storage Temperature: -40°C to +60°C
- Operating Temperature: -40°C to +125°C

MECHANICAL

- Insulator Material: PA4T, UL94 V0, Halogen Free
- Contact Material: Beryllium Copper Alloy
- Plating: Gold / Tin over Nickel
- Durability: 50 Cycles

HOW TO ORDER

00 Prefix
9159 Series
0XX Number of Ways
801 Wire Gauge Size
9 Insulator Color
06 Plating Option

801 = Dual Entry Card Edge
9 = UL White
06 = Gold/tin over Nickel

Code	Position
004	2 X 2
006	2 X 3
008	2 X 4
010	2 X 5
012	2 X 6
014	2 X 7
016	2 X 8
018	2 X 9
020	2 X 10



Safety Standards: UL 1977-File #E90723



The Important Information/Disclaimer is incorporated in the catalog where these specifications came from or available online at www.kyocera-avx.com/disclaimer/ by reference and should be reviewed in full before placing any order.

9159-800 DUAL ENTRY CARD EDGE CONNECTOR



NOTES:

1. HOUSING MATERIAL: GLASS-FILLED, HIGH TEMPERATURE NYLON; FLAME RETARDANT PER UL94V-0; HALOGEN FREE; COLOR: WHITE.
2. CONTACT MATERIAL: HIGH STRENGTH COPPER ALLOY.
3. CONTACT PLATING: GOLD OVER DUCTILE NICKEL.
4. STOP SHOULDERS TO ENSURE PROPER PAD POSITION IN CONNECTOR. 0.75 DIMENSIONS APPLY ONLY WHEN MATING FROM BELOW PCB.
5. PART NOT SUITABLE FOR METAL CORE PRINTED CIRCUIT BOARDS.

Part Number	Position	DIM. A	DIM. B	DIM. C	DIM. D	DIM. E	TAPE WIDTH
00-9159-004-801-906	2 X 2	4.00	2.50	1.00	2.30	4.25	16
00-9159-006-801-906	2 X 3	5.00	3.50	2.00	3.30	5.25	16
00-9159-008-801-906	2 X 4	6.00	4.50	3.00	4.30	6.25	16
00-9159-010-801-906	2 X 5	7.00	5.50	4.00	5.30	7.25	24
00-9159-012-801-906	2 X 6	8.00	6.50	5.00	6.30	8.25	24
00-9159-014-801-906	2 X 7	9.00	7.50	6.00	7.30	9.25	24
00-9159-016-801-906	2 X 8	10.00	8.50	7.00	8.30	10.25	24
00-9159-018-801-906	2 X 9	11.00	9.50	8.00	9.30	11.25	24
00-9159-020-801-906	2 X 10	12.00	10.50	9.00	10.30	12.25	24

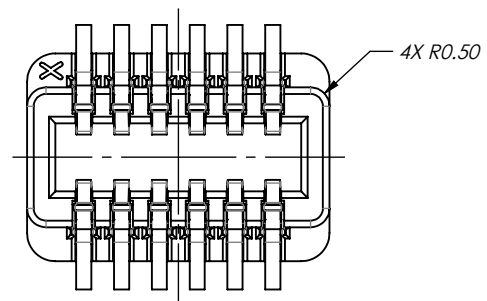
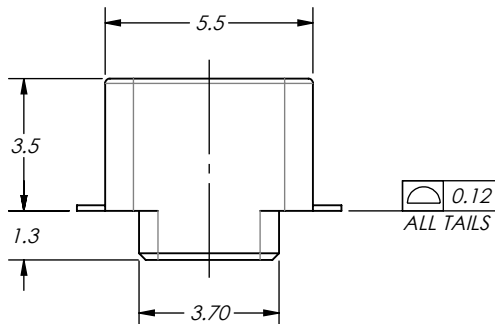
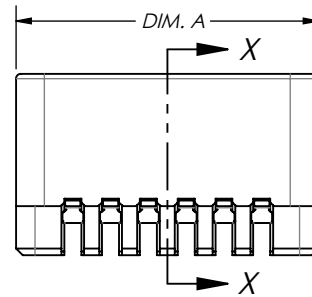
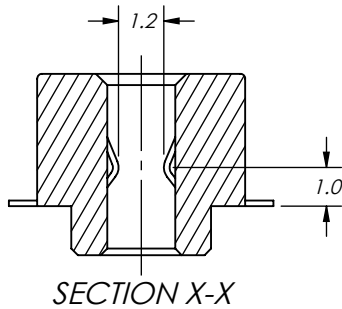
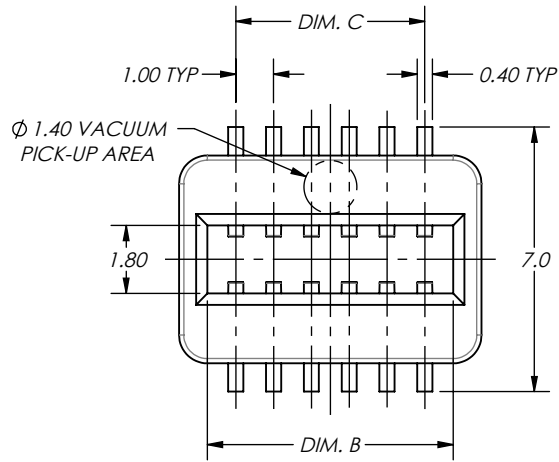
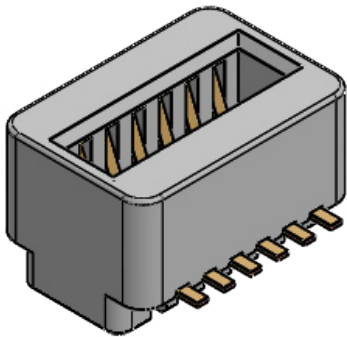

9159-800 DUAL ENTRY CARD EDGE CONNECTOR

Part Number	Position	DIM. A	DIM. B	DIM. C	DIM. D	DIM. E	TAPE WIDTH
00-9159-004-801-906	2 X 2	4.00	2.50	1.00	2.30	4.25	16
00-9159-006-801-906	2 X 3	5.00	3.50	2.00	3.30	5.25	16
00-9159-008-801-906	2 X 4	6.00	4.50	3.00	4.30	6.25	16
00-9159-010-801-906	2 X 5	7.00	5.50	4.00	5.30	7.25	24
00-9159-012-801-906	2 X 6	8.00	6.50	5.00	6.30	8.25	24
00-9159-014-801-906	2 X 7	9.00	7.50	6.00	7.30	9.25	24
00-9159-016-801-906	2 X 8	10.00	8.50	7.00	8.30	10.25	24
00-9159-018-801-906	2 X 9	11.00	9.50	8.00	9.30	11.25	24
00-9159-020-801-906	2 X 10	12.00	10.50	9.00	10.30	12.25	24

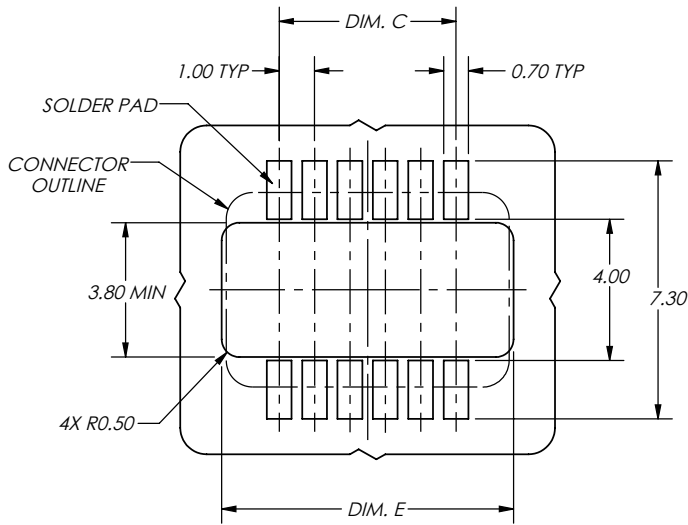

MOUNTING PCB CONFIGURATION

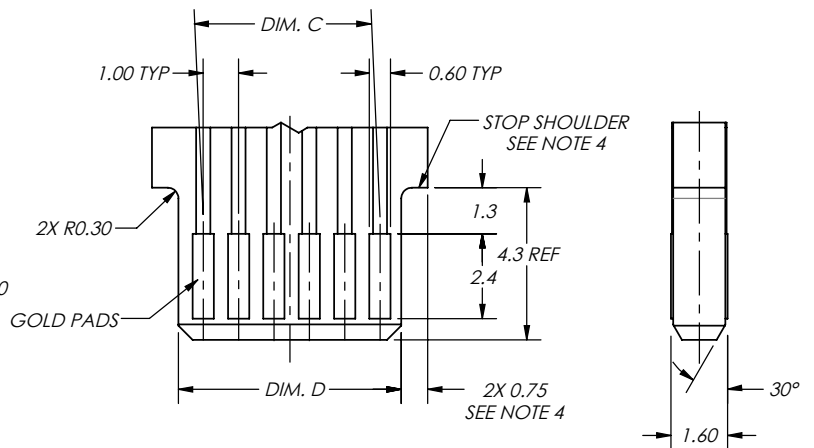

MATING PCB CONFIGURATION (BOTH SIDES)

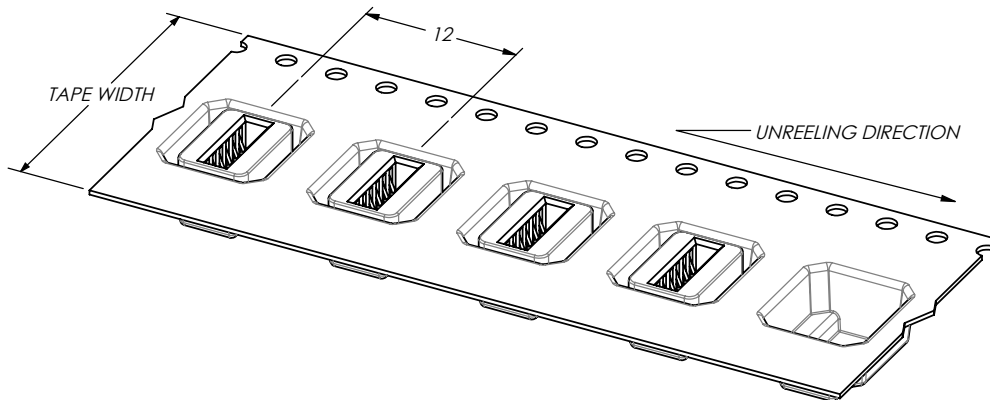

PACKAGING PER EIA-482
1,000 PARTS PER 330 mm REEL

X-ON Electronics

Largest Supplier of Electrical and Electronic Components

Click to view similar products for [Standard Card Edge Connectors](#) category:

Click to view products by [Kyocera AVX](#) manufacturer:

Other Similar products are found below :

[CR7E-30DB-3.96E\(72\)](#) [6565204-6](#) [1437274-4](#) [1-582587-1](#) [284-0102-12100](#) [286-0052-12101A](#) [306022901000000](#) [A6D22DS29C2](#) [287-0032-12101](#) [306-028-525-102](#) [307-072-526-202](#) [330-030-500-278](#) [345-060-559-303](#) [534671-1](#) [341-240-317](#) [345-044-500-300](#) [346-240-318](#) [C7D10DS29C1M133](#) [395-100-524-300](#) [09-07-2032](#) [10035388-802LF](#) [10115859-011LF](#) [10122859-009LF](#) [101269333204245CLF](#) [66925-516LF](#) [5145409-2](#) [73726-0005](#) [66308-1](#) [5036A30](#) [KSLX-62-BR](#) [CE100F28-3-D](#) [CE100F28-4-D](#) [CE156F22-9-C](#) [CT100F24-3-D](#) [MLSS100-12-C](#) [SCC100F-11-C](#) [SCC100F-20-C](#) [SCC100F-24-C](#) [SCC100F-25-C](#) [3-530656](#) [2512250177](#) [285-0112-12300](#) [346-068-556-300](#) [284-0492-11000](#) [287-0032-12301](#) [10139371-1824ALF](#) [1-1534798-3](#) [CR7C-28DA-4DS](#) [101269330808201ALF](#) [CR7E-44DA-3.96E](#)