

Male Style 1/2 M

Series 8483

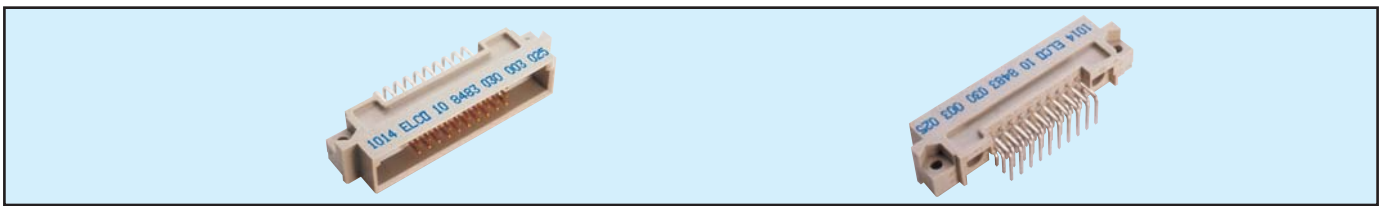

Contact Design and Termination Length	No. of Cavities For Signal Contacts	No. of Cavities for Special Contacts	Loading Description	Part Number Performance classes according to DIN 41612	
				II	I
3.0 mm (Y) Straight	12 (3 x 4)	4	a + b + c fully loaded	10 8483 012 001 025	10 8483 012 001 049
				10 8483 030 001 025	10 8483 030 001 049
11.4 mm (Y) Straight	12 (3 x 4)	4	a + b + c fully loaded	10 8483 012 002 025	10 8483 012 002 049
				10 8483 030 002 025	10 8483 030 002 049
3.0 mm (Y) Right Angled	12 (3 x 4)	4	a + b + c fully loaded	10 8483 012 003 025	10 8483 012 003 049
				10 8483 030 003 025	10 8483 030 003 049
11.3mm (Y) Right Angled	12 (3 x 4)	4	a + b + c fully loaded	10 8483 012 004 025	10 8483 012 004 049
				10 8483 030 004 025	10 8483 030 004 049
Solder hole rows a + c 6.1 mm row b 8.8 mm	12 (3 x 4)	4	a + b + c fully loaded	10 8483 012 006 025	10 8483 012 006 049
				10 8483 030 006 025	10 8483 030 006 049

NB: Additional Plating & Loading Variations: Please contact your local AVX sales office or distributor.

LOADING DESCRIPTION

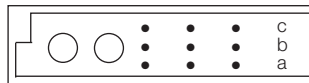

4 contacts, rows a + b + c fully loaded

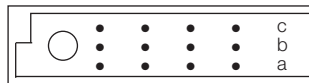

2 contacts, rows a + b + c fully loaded

DIMENSIONS

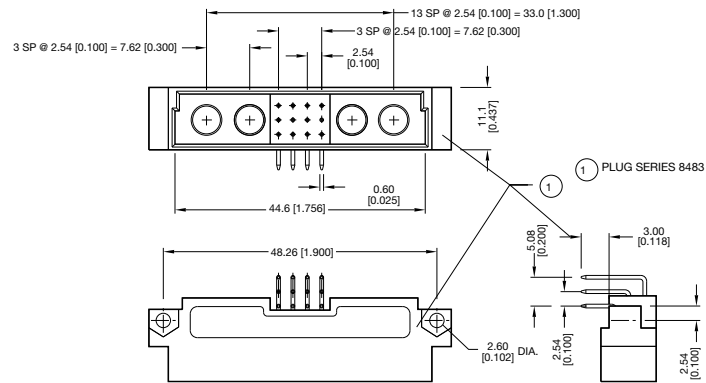

CONTACT ARRANGEMENT

	Variations Receptacle (Mating Side)					Max. Pin Counts
	15	12	9	8	5	
a						30+ Max. 2 Signal Contacts
b						
c						
a						12+ Max. 4 Signal Contacts
b						
c						

Male Style M

Series 8483 – Fully loaded

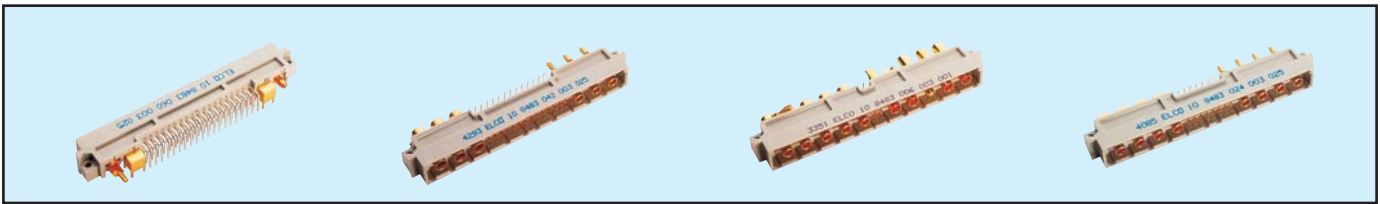

Contact Design and Termination Length	No. of Cavities For Signal Contacts	No. of Cavities for Special Contacts	Loading Description	Part Number Performance classes according to DIN 41612	
				II	I
3.0 mm (Y) Straight	6 (3 x 2)	10	a + b + c fully loaded	10 8483 006 001 025	10 8483 006 001 049
	24 (3 x 8)	8	a + b + c fully loaded	10 8483 024 001 025	10 8483 024 001 049
	42 (3 x 14)	6	a + b + c fully loaded	10 8483 042 001 025	10 8483 042 001 049
	60 (3 x 20)	4	a + b + c fully loaded	10 8483 060 001 025	10 8483 060 001 049
	78 (3 x 26)	2	a + b + c fully loaded	10 8483 078 001 025	10 8483 078 001 049
11.4 mm (Y) Straight	6 (3 x 2)	10	a + b + c fully loaded	10 8483 006 002 025	10 8483 006 002 049
	24 (3 x 8)	8	a + b + c fully loaded	10 8483 024 002 025	10 8483 024 002 049
	42 (3 x 14)	6	a + b + c fully loaded	10 8483 042 002 025	10 8483 042 002 049
	60 (3 x 20)	4	a + b + c fully loaded	10 8483 060 002 025	10 8483 060 002 049
	78 (3 x 26)	2	a + b + c fully loaded	10 8483 078 002 025	10 8483 078 002 049
3.0 mm (Y) Right Angled	6 (3 x 2)	10	a + b + c fully loaded	10 8483 006 003 025	10 8483 006 003 049
	24 (3 x 8)	8	a + b + c fully loaded	10 8483 024 003 025	10 8483 024 003 049
	42 (3 x 14)	6	a + b + c fully loaded	10 8483 042 003 025	10 8483 042 003 049
	60 (3 x 20)	4	a + b + c fully loaded	10 8483 060 003 025	10 8483 060 003 049
	78 (3 x 26)	2	a + b + c fully loaded	10 8483 078 003 025	10 8483 078 003 049
11.3mm (Y) Right Angled	6 (3 x 2)	10	a + b + c fully loaded	10 8483 006 004 025	10 8483 006 004 049
	24 (3 x 8)	8	a + b + c fully loaded	10 8483 024 004 025	10 8483 024 004 049
	42 (3 x 14)	6	a + b + c fully loaded	10 8483 042 004 025	10 8483 042 004 049
	60 (3 x 20)	4	a + b + c fully loaded	10 8483 060 004 025	10 8483 060 004 049
	78 (3 x 26)	2	a + b + c fully loaded	10 8483 078 004 025	10 8483 078 004 049
Solder hole rows a + c 6.1 mm row b 8.8 mm	6 (3 x 2)	10	a + b + c fully loaded	10 8483 006 006 025	10 8483 006 006 049
	24 (3 x 8)	8	a + b + c fully loaded	10 8483 024 006 025	10 8483 024 006 049
	42 (3 x 14)	6	a + b + c fully loaded	10 8483 042 006 025	10 8483 042 006 049
	60 (3 x 20)	4	a + b + c fully loaded	10 8483 060 006 025	10 8483 060 006 049
	78 (3 x 26)	2	a + b + c fully loaded	10 8483 078 006 025	10 8483 078 006 049

NB: Additional Plating & Loading Variations: Please contact your local AVX sales office or distributor.

LOADING DESCRIPTION

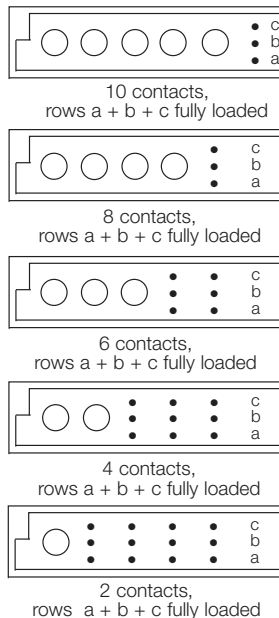

DIMENSIONS

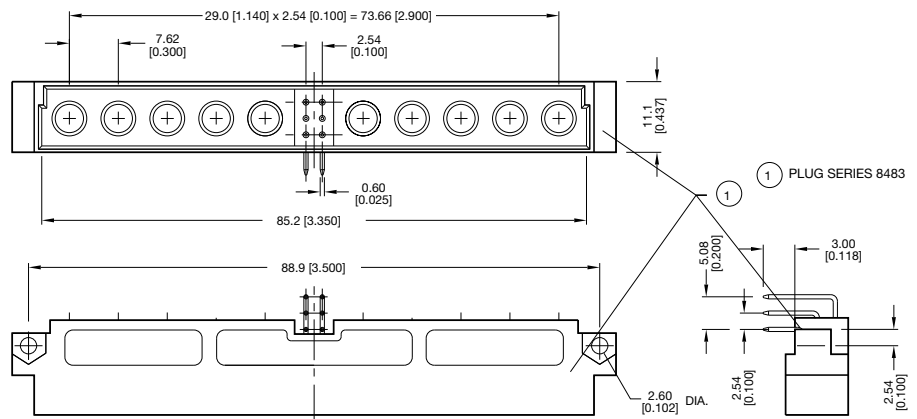



See Page 45 for board layout

Female Style M

Series 8483 – Fully loaded



Contact Design and Termination Length	No. of Cavities For Signal Contacts	No. of Cavities for Special Contacts	Loading Description	Part Number Performance classes according to DIN 41612	
				II	I
4.5 mm (Y) Straight 	6 (3 x 2)	10	a + b + c fully loaded	20 8483 006 001 025	20 8483 006 001 049
	24 (3 x 8)	8	a + b + c fully loaded	20 8483 024 001 025	20 8483 024 001 049
	42 (3 x 14)	6	a + b + c fully loaded	20 8483 042 001 025	20 8483 042 001 049
	60 (3 x 20)	4	a + b + c fully loaded	20 8483 060 001 025	20 8483 060 001 049
	78 (3 x 26)	2	a + b + c fully loaded	20 8483 078 001 025	20 8483 078 001 049
2.9 mm (Y) Straight 	6 (3 x 2)	10	a + b + c fully loaded	20 8483 006 002 025	20 8483 006 002 049
	24 (3 x 8)	8	a + b + c fully loaded	20 8483 024 002 025	20 8483 024 002 049
	42 (3 x 14)	6	a + b + c fully loaded	20 8483 042 002 025	20 8483 042 002 049
	60 (3 x 20)	4	a + b + c fully loaded	20 8483 060 002 025	20 8483 060 002 049
	78 (3 x 26)	2	a + b + c fully loaded	20 8483 078 002 025	20 8483 078 002 049
13.0 mm (Y) Straight 	6 (3 x 2)	10	a + b + c fully loaded	20 8483 006 003 025	20 8483 006 003 049
	24 (3 x 8)	8	a + b + c fully loaded	20 8483 024 003 025	20 8483 024 003 049
	42 (3 x 14)	6	a + b + c fully loaded	20 8483 042 003 025	20 8483 042 003 049
	60 (3 x 20)	4	a + b + c fully loaded	20 8483 060 003 025	20 8483 060 003 049
	78 (3 x 26)	2	a + b + c fully loaded	20 8483 078 003 025	20 8483 078 003 049

NB: Additional Plating & Loading Variations: Please contact your local AVX sales office or distributor.

LOADING DESCRIPTION



10 contacts,
rows a + b + c fully loaded



8 contacts,
rows a + b + c fully loaded



6 contacts,
rows a + b + c fully loaded



4 contacts,
rows a + b + c fully loaded

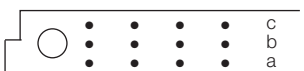

2 contacts,
rows a + b + c fully loaded

DIMENSIONS

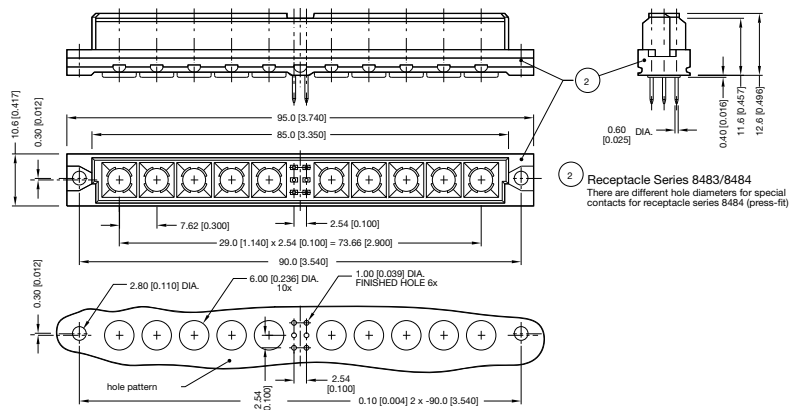

CONTACT ARRANGEMENT		max pin counts
variations receptacle (mating side) 31 28 25 22 19 17 16 14 11 8 5 2		
a		78+ max 2 special contacts
b		60+ max 4 special contacts
c		42+ max 6 special contacts
a		24+ max 8 special contacts
b		6+ max 10 special contacts

See Page 45 for board layout

Male Style M



Series 8483 – a + c loaded

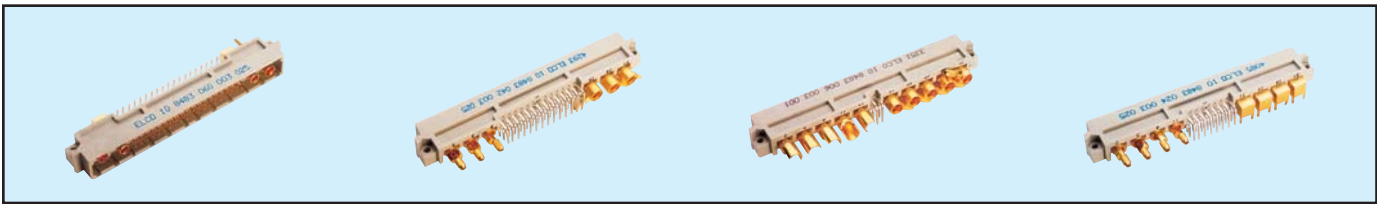

Contact Design and Termination Length	No. of Cavities For Signal Contacts	No. of Cavities for Special Contacts	Loading Description	Part Number Performance classes according to DIN 41612	
				II	I
3.0 mm (Y) Straight	6 (3 x 2)	10	a + c fully loaded	10 8483 006 001 026	10 8483 006 001 050
	24 (3 x 8)	8	a + c fully loaded	10 8483 024 001 026	10 8483 024 001 050
	42 (3 x 14)	6	a + c fully loaded	10 8483 042 001 026	10 8483 042 001 050
	60 (3 x 20)	4	a + c fully loaded	10 8483 060 001 026	10 8483 060 001 050
	78 (3 x 26)	2	a + c fully loaded	10 8483 078 001 026	10 8483 078 001 050
11.4 mm (Y) Straight	6 (3 x 2)	10	a + c fully loaded	10 8483 006 002 026	10 8483 006 002 050
	24 (3 x 8)	8	a + c fully loaded	10 8483 024 002 026	10 8483 024 002 050
	42 (3 x 14)	6	a + c fully loaded	10 8483 042 002 026	10 8483 042 002 050
	60 (3 x 20)	4	a + c fully loaded	10 8483 060 002 026	10 8483 060 002 050
	78 (3 x 26)	2	a + c fully loaded	10 8483 078 002 026	10 8483 078 002 050
3.0 mm (Y) Right Angled	6 (3 x 2)	10	a + c fully loaded	10 8483 006 003 026	10 8483 006 003 050
	24 (3 x 8)	8	a + c fully loaded	10 8483 024 003 026	10 8483 024 003 050
	42 (3 x 14)	6	a + c fully loaded	10 8483 042 003 026	10 8483 042 003 050
	60 (3 x 20)	4	a + c fully loaded	10 8483 060 003 026	10 8483 060 003 050
	78 (3 x 26)	2	a + c fully loaded	10 8483 078 003 026	10 8483 078 003 050
11.3mm (Y) Right Angled	6 (3 x 2)	10	a + c fully loaded	10 8483 006 004 026	10 8483 006 004 050
	24 (3 x 8)	8	a + c fully loaded	10 8483 024 004 026	10 8483 024 004 050
	42 (3 x 14)	6	a + c fully loaded	10 8483 042 004 026	10 8483 042 004 050
	60 (3 x 20)	4	a + c fully loaded	10 8483 060 004 026	10 8483 060 004 050
	78 (3 x 26)	2	a + c fully loaded	10 8483 078 004 026	10 8483 078 004 050
Solder eyelet rows a + c 4.8 mm row b 7.5 mm	6 (3 x 2)	10	a + c fully loaded	10 8483 006 005 026	10 8483 006 005 050
	24 (3 x 8)	8	a + c fully loaded	10 8483 024 005 026	10 8483 024 005 050
	42 (3 x 14)	6	a + c fully loaded	10 8483 042 005 026	10 8483 042 005 050
	60 (3 x 20)	4	a + c fully loaded	10 8483 060 005 026	10 8483 060 005 050
	78 (3 x 26)	2	a + c fully loaded	10 8483 078 005 026	10 8483 078 005 050

NB: Additional Plating & Loading Variations: Please contact your local AVX sales office or distributor.

LOADING DESCRIPTION

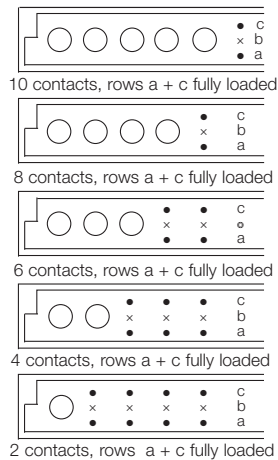

DIMENSIONS

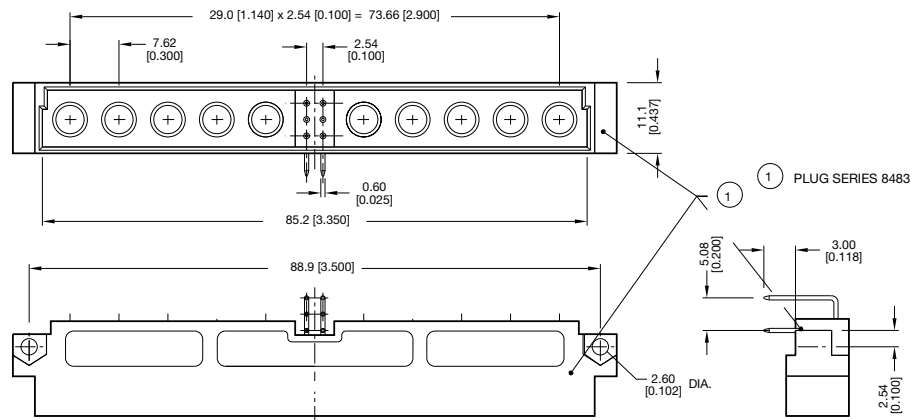

See Page 45 for board layout

Female Style M

Series 8483 – a + c loaded



Contact Design and Termination Length	No. of Cavities For Signal Contacts	No. of Cavities for Special Contacts	Loading Description	Part Number Performance classes according to DIN 41612	
				II	I
4.5 mm (Y) Straight	6 (3 x 2)	10	a + c fully loaded	20 8483 006 001 026	20 8483 006 001 050
	24 (3 x 8)	8	a + c fully loaded	20 8483 024 001 026	20 8483 024 001 050
	42 (3 x 14)	6	a + c fully loaded	20 8483 042 001 026	20 8483 042 001 050
	60 (3 x 20)	4	a + c fully loaded	20 8483 060 001 026	20 8483 060 001 050
	78 (3 x 26)	2	a + c fully loaded	20 8483 078 001 026	20 8483 078 001 050
2.9 mm (Y) Straight	6 (3 x 2)	10	a + c fully loaded	20 8483 006 002 026	20 8483 006 002 050
	24 (3 x 8)	8	a + c fully loaded	20 8483 024 002 026	20 8483 024 002 050
	42 (3 x 14)	6	a + c fully loaded	20 8483 042 002 026	20 8483 042 002 050
	60 (3 x 20)	4	a + c fully loaded	20 8483 060 002 026	20 8483 060 002 050
	78 (3 x 26)	2	a + c fully loaded	20 8483 078 002 026	20 8483 078 002 050
13.0 mm (Y) Straight	6 (3 x 2)	10	a + c fully loaded	20 8483 006 003 026	20 8483 006 003 050
	24 (3 x 8)	8	a + c fully loaded	20 8483 024 003 026	20 8483 024 003 050
	42 (3 x 14)	6	a + c fully loaded	20 8483 042 003 026	20 8483 042 003 050
	60 (3 x 20)	4	a + c fully loaded	20 8483 060 003 026	20 8483 060 003 050
	78 (3 x 26)	2	a + c fully loaded	20 8483 078 003 026	20 8483 078 003 050

NB: Additional Plating & Loading Variations: Please contact your local AVX sales office or distributor.

LOADING DESCRIPTION



10 contacts,
rows a + c fully loaded



8 contacts,
rows a + c fully loaded

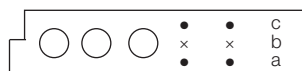

6 contacts,
rows a + c fully loaded

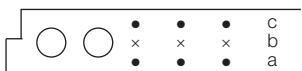

4 contacts,
rows a + c fully loaded

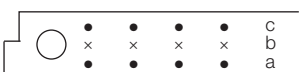

2 contacts,
rows a + c fully loaded

DIMENSIONS

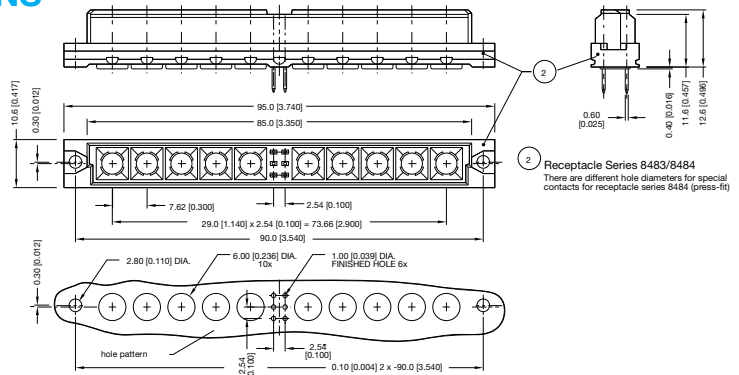

Receptacle Series 8483/8484
There are different hole diameters for special contacts for receptacle series 8484 (press-fit)

CONTACT ARRANGEMENT		max pin counts
variations receptacle (mating side)		
a	31 28 25 22 19 17 16 14 11 8 5 2	78+ max 2 special contacts
b		60+ max 4 special contacts
c		42+ max 6 special contacts
a		24+ max 8 special contacts
b		6+ max 10 special contacts
c		

See Page 45 for board layout

X-ON Electronics

Largest Supplier of Electrical and Electronic Components

Click to view similar products for [DIN 41612 Connectors](#) category:

Click to view products by [Kyocera AVX](#) manufacturer:

Other Similar products are found below :

[004.767](#) [608489050008049](#) [691327-1](#) [74670-0732](#) [74680-0340](#) [75880-0015](#) [76453-0014](#) [86093159ALF](#) [9732967801](#) [QLC260R](#)
[120X10019X](#) [120X10089X](#) [122A10249X](#) [122A11089X](#) [122A13089X](#) [122A10089X](#) [122A10129X](#) [122A10349X](#) [122A13359X](#) [1377391-4](#)
[DIN-048CPC-SR1-MH](#) [1393583-2](#) [1393726-7](#) [140X10129X](#) [143-1913-000](#) [143-1908-000](#) [1484472-1](#) [2110070-1](#) [2110070-2](#) [CBC20T00-](#)
[008FDS5-0-1-002VR](#) [172699-5036](#) [2-1393557-4](#) [2-1437084-2](#) [394506](#) [419-2080-402](#) [V42254B2202C968](#) [419-2086-201](#) [419-2087-002](#)
[448657-1](#) [448847-3](#) [5-1393755-9](#) [02990000004](#) [054302](#) [043556](#) [09062483201750](#) [0850033067](#) [09031646555](#) [09061486901840](#)
[09185107324800](#) [102A10019X](#)