

POKE HOME: VERTICAL CONTACT THRU-BOARD WIRE INSERTION 12-18 AWG: 9296-11X

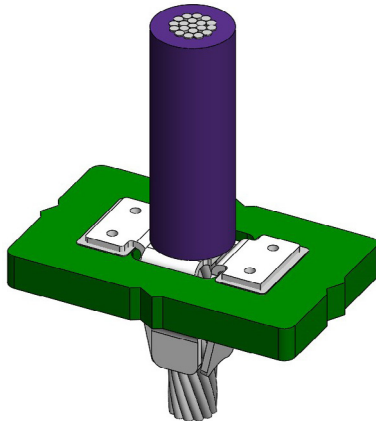

General Information



GENERAL DESCRIPTION

KYOCERA AVX continues to develop unique connectors to fill the gap in the market. The newest addition to AVX's broadening line of wire to board poke-home is the 12-18AWG box contact 9296-11X, which is extension of popular vertical poke-home contact 70-9296. This new box contact will allow all 12-18 AWG solid wires and stranded wires. All wire types can be used in both plated and un-plated condition.

This small contact is packed with several key features that provide significant functionality in a broad range of applications. The contact is designed for PCB surface mount and termination is accomplished with 12-18AWG wires pushed directly into the contact.

APPLICATIONS

Provides a one piece wire to board contact solution in applications :

- Machine Controls: motors, drives, solenoids, sensors, battery packs, fans and pumps
- Commercial Buildings: controls, security, fire and sensors
- SSL/LED: Fixtures, signage and street lights
- Home appliance: Vacuums and floor cares, washing machines, dryers

FEATURES AND BENEFITS

- Maximum 20 Amps current rating meets robust application requirements
- Accepts 12-18 AWG solid and stranded wires
- Box contact with side walls provides maximum mechanical stability and wire retention
- Tape and reel packaged for automated SMT placement
- UL approved

ELECTRICAL

- Current Rating: Maximum 20 Amps
- Voltage Rating: 300 VAC (RMS) or DC equivalent

ENVIRONMENTAL

- Operating Temperature: -40°C to +130°C
- Storage Temperature: -40°C to +70°C

MECHANICAL

- Contact Material : Phosphor Bronze
- Plating: Pure tin plating

HOW TO ORDER

70

Prefix

9296

Series

001

Number of Ways

11X

Wire Gauge Size
114 = 16/18 AWG
115 = 14 AWG
116 = 12 AWG

006

Plating Options
006 = Pure Tin



CURRENT RATING

		70-9176-001-114-006		70-9176-001-115-006	70-9176-001-116-006
Wire		18 AWG	16 AWG	14AWG	12AWG
UL	Solid	12 Amps	14 Amps	17 Amps	20 Amps
	Stranded	12 Amps	14 Amps	17 Amps	20 Amps
cUL	Solid	11 Amps	14 Amps	15 Amps	20 Amps
	Stranded	11 Amps	14 Amps	15 Amps	20 Amps

Safety Standards: UL 1977-File #E90723

POKE HOME: VERTICAL CONTACT THRU-BOARD WIRE INSERTION 12-18 AWG: 9296-11X



9296 Vertical Contact Thru-Board Wire Insertion

70-9296-001-116-006: 12 AWG

VERTICAL CONTACT THRU-BOARD WIRE INSERTION

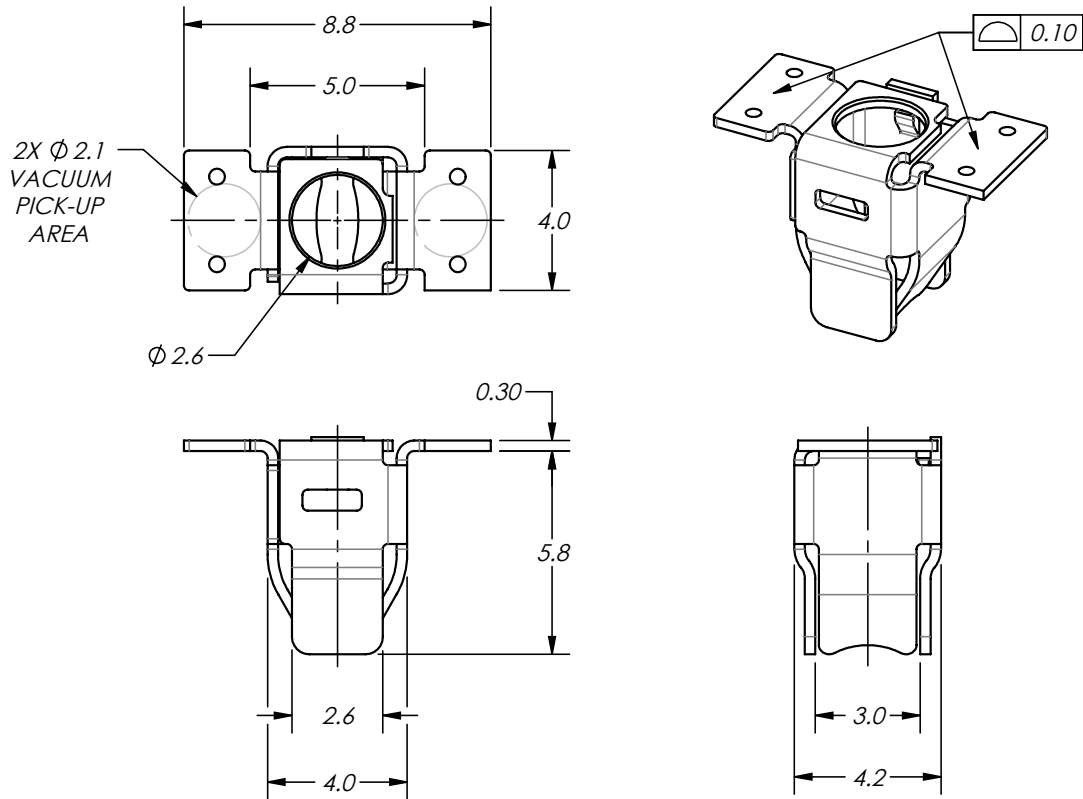

Notes

1. PART IS DESIGNED FOR USE WITH 12 AWG SOLID OR STRANDED WIRE.
2. MATERIAL: TIN-PLATED PHOSPHOR-BRONZE.
3. STRIPPED, STRANDED WIRE MUST BE PROPERLY TWISTED OR TINNED TO FUNCTION CORRECTLY.
4. CONTACT IS NOT DESIGNED FOR WIRE TO BE REMOVED AND RE-INSERTED.
5. FOR FURTHER INFORMATION, SEE KAVX PRODUCT SPEC 201-001-161 AND APPLICATION NOTES 201-01-167.
6. UL REFERENCE E90723 (US AND CANADA).

POKE HOME: VERTICAL CONTACT THRU-BOARD WIRE INSERTION 12-18 AWG: 9296-11X



Wire Detail/PCB Layout/Packing Details

70-9296-001-116-006: 12 AWG

VERTICAL CONTACT THRU-BOARD WIRE INSERTION

WIRE DETAIL

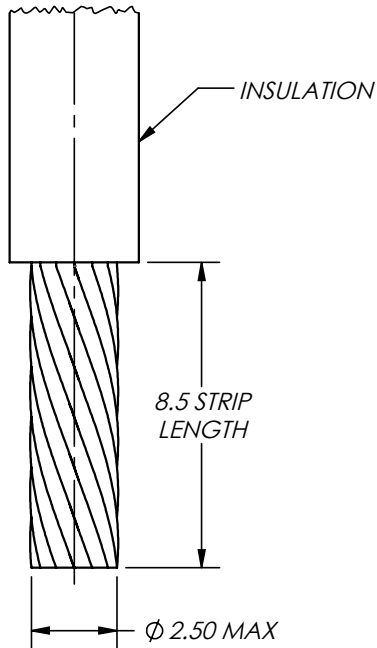

SUGGESTED PCB LAYOUT

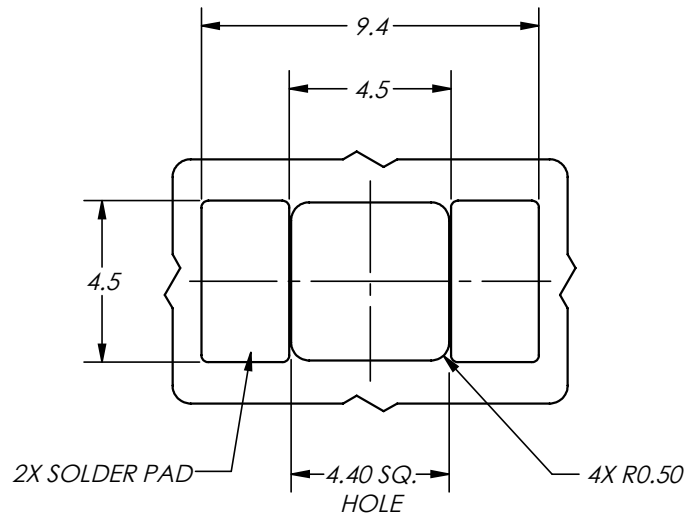

PACKING DETAILS

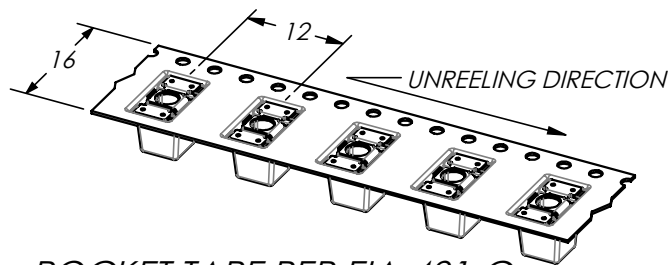

POCKET TAPE PER EIA-481-C
800 PARTS PER 330 mm REEL

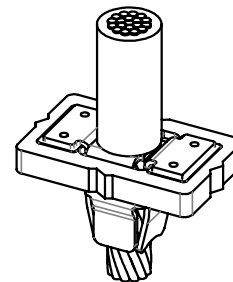

POKE HOME: VERTICAL CONTACT THRU-BOARD WIRE INSERTION 12-18 AWG: 9296-11X



9296 Vertical Contact Thru-Board Wire Insertion

70-9296-001-115-006: 14 AWG

VERTICAL CONTACT THRU-BOARD WIRE INSERTION

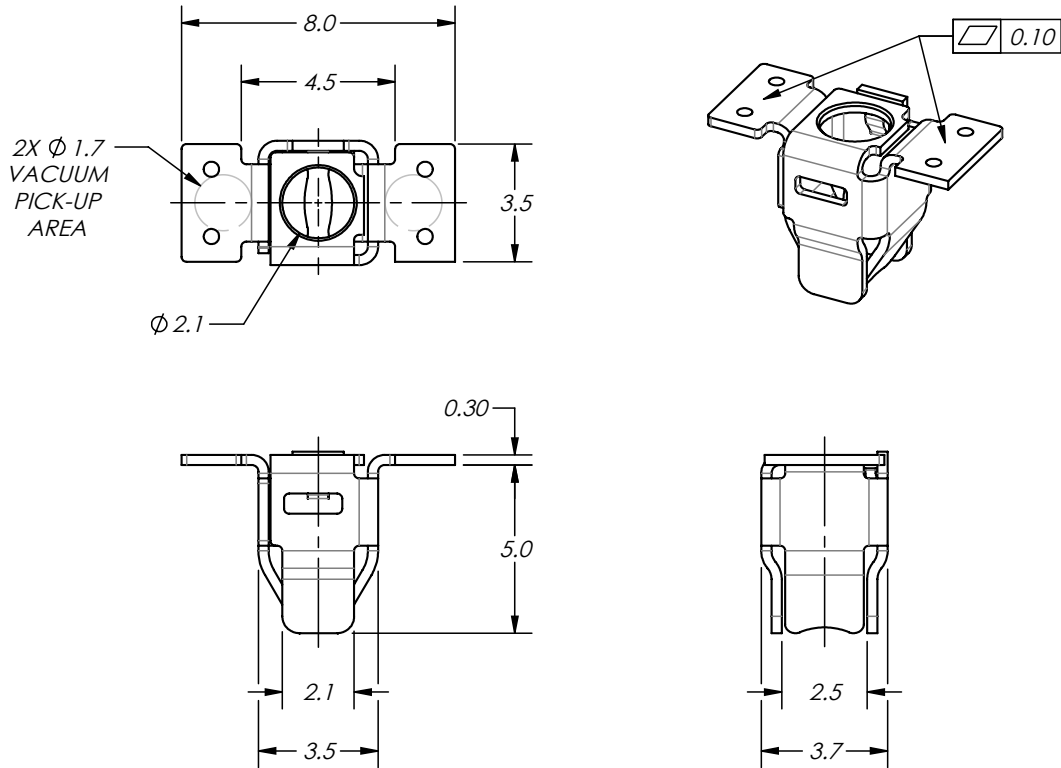

Notes

1. PART IS DESIGNED FOR USE WITH 14 AWG SOLID OR STRANDED WIRE.
2. MATERIAL: TIN-PLATED PHOSPHOR-BRONZE.
3. STRIPPED, STRANDED WIRE MUST BE PROPERLY TWISTED OR TINNED TO FUNCTION CORRECTLY.
4. CONTACT IS NOT DESIGNED FOR WIRE TO BE REMOVED AND RE-INSERTED.
5. FOR FURTHER INFORMATION, SEE KAVX PRODUCT SPEC 201-001-161 AND APPLICATION NOTES 201-01-167.
6. UL REFERENCE E90723 (US AND CANADA).

POKE HOME: VERTICAL CONTACT THRU-BOARD WIRE INSERTION 12-18 AWG: 9296-11X



Wire Detail/PCB Layout/Packing Details

70-9296-001-115-006: 14 AWG

VERTICAL CONTACT THRU-BOARD WIRE INSERTION

WIRE DETAIL

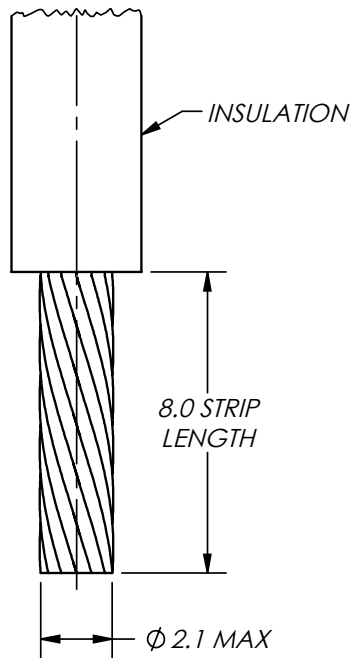

SUGGESTED PCB LAYOUT

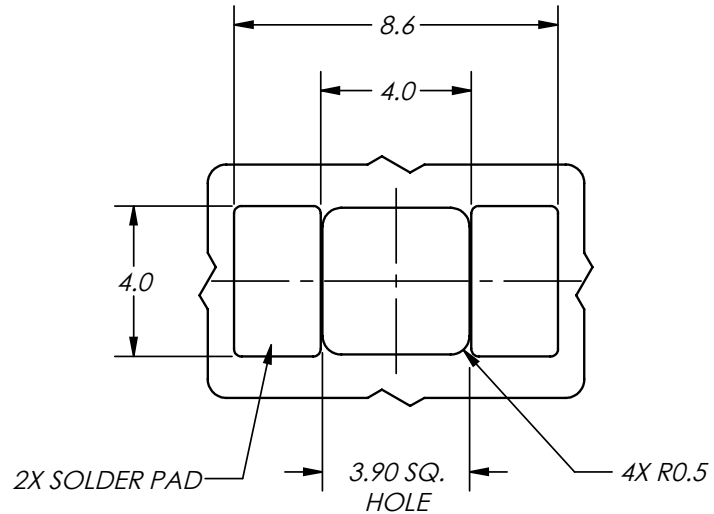

PACKING DETAILS

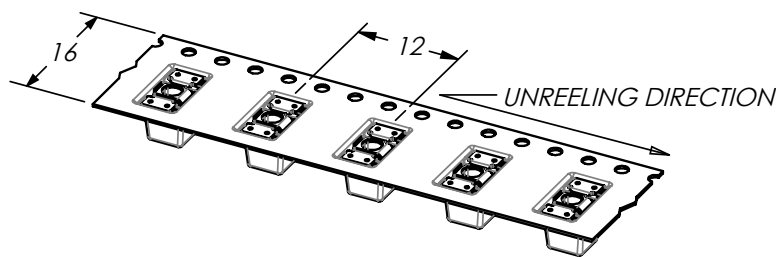

POCKET TAPE PER EIA-481-C

900 PARTS PER 330 mm REEL

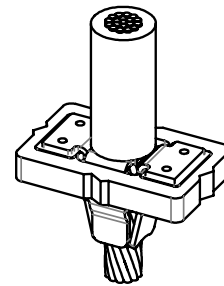

POKE HOME: VERTICAL CONTACT THRU-BOARD WIRE INSERTION 12-18 AWG: 9296-11X



9296 Vertical Contact Thru-Board Wire Insertion

70-9296-001-114-006: 16-18 AWG VERTICAL CONTACT THRU-BOARD WIRE INSERTION

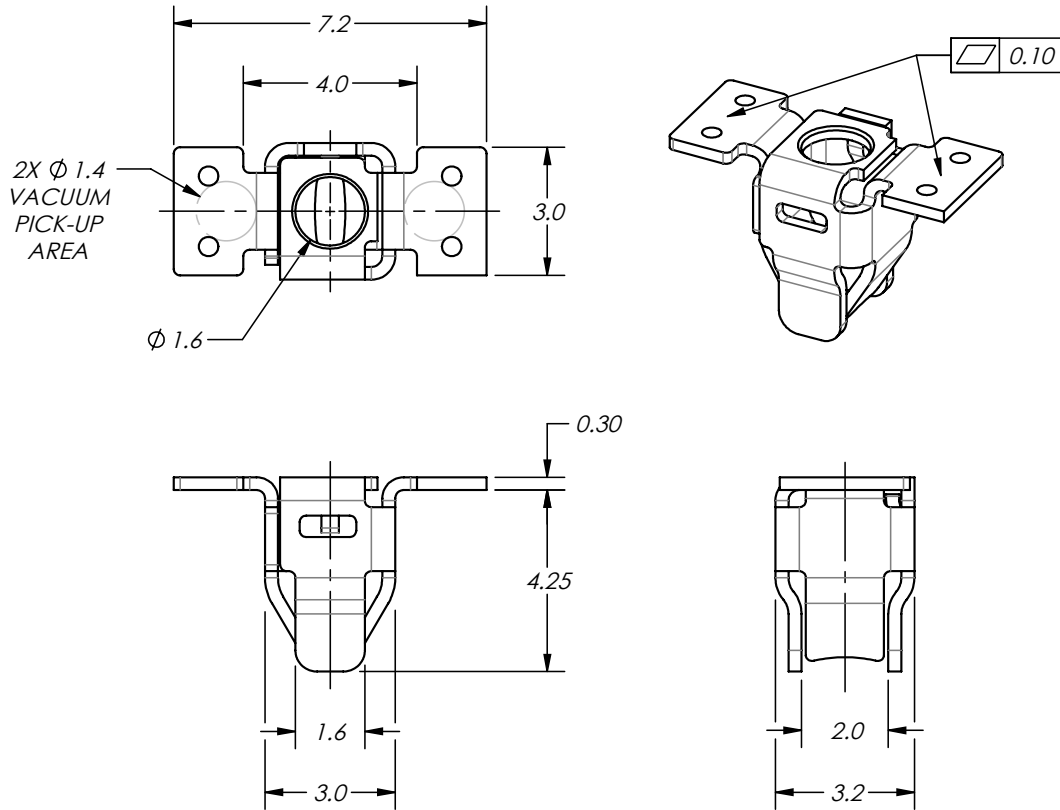

Notes

1. PART IS DESIGNED FOR USE WITH 16-18 AWG SOLID OR STRANDED WIRE.
2. MATERIAL: TIN-PLATED PHOSPHOR-BRONZE.
3. STRIPPED, STRANDED WIRE MUST BE PROPERLY TWISTED OR TINNED TO FUNCTION CORRECTLY.
4. CONTACT IS NOT DESIGNED FOR WIRE TO BE REMOVED AND RE-INSERTED.
5. UL REFERENCE E90723 (US AND CANADA).

POKE HOME: VERTICAL CONTACT THRU-BOARD WIRE INSERTION 12-18 AWG: 9296-11X



Wire Detail/PCB Layout/Packing Details

70-9296-001-114-006: 16-18 AWG

VERTICAL CONTACT THRU-BOARD WIRE INSERTION

WIRE DETAIL

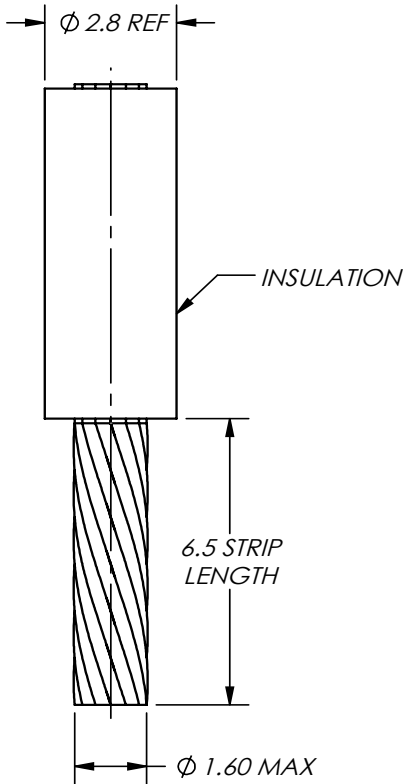

SUGGESTED PCB LAYOUT

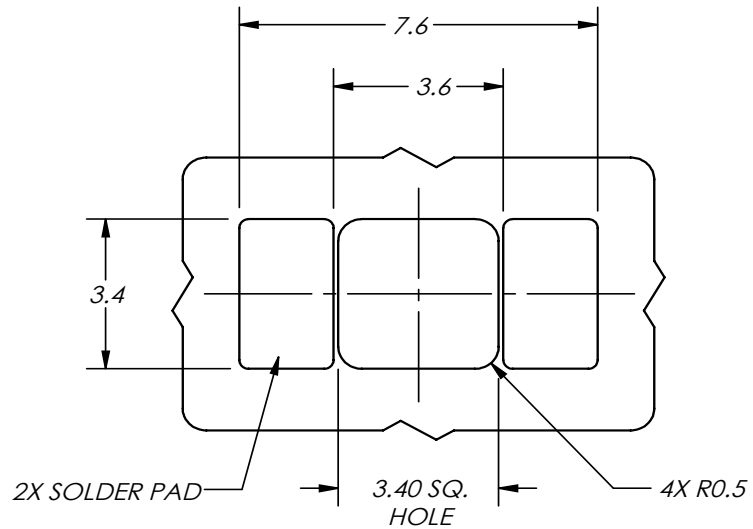

PACKING DETAILS

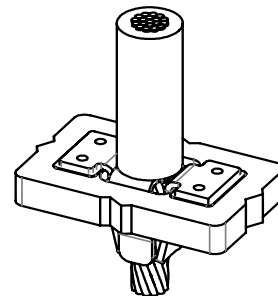
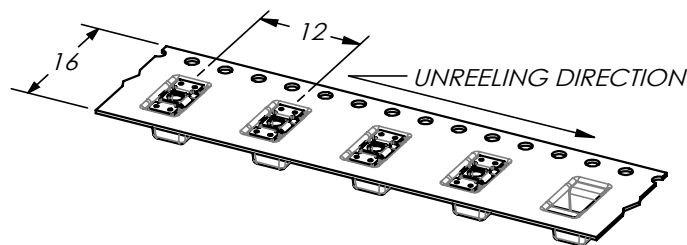

POCKET TAPE PER EIA-481-C
1,000 PARTS PER 330 mm REEL

X-ON Electronics

Largest Supplier of Electrical and Electronic Components

Click to view similar products for [Terminals category](#):

Click to view products by [Kyocera AVX manufacturer](#):

Other Similar products are found below :

[00-054007-01074-6](#) [00-054007-70206-1](#) [00-054007-70210-8](#) [00-054007-70217-7](#) [00-054007-70228-3](#) [00-054007-70256-6](#) [00-054007-70316-7](#) [00-054007-49560-4](#) [00-054007-70209-2](#) [00-054007-70231-3](#) [00-054007-70241-2](#) [00-054007-70242-9](#) [00-054007-70246-7](#) [00-054007-70263-4](#) [00-054007-70288-7](#) [00-054007-70290-0](#) [00-054007-70300-6](#) [00-054007-70304-4](#) [01-2900-1-04412](#) [00581P0075](#) [600TS-10](#) [605601-1](#) [60598-1-CUT-TAPE](#) [60617-1-C](#) [61314-6-C](#) [61810-3](#) [62149-1](#) [626-0194](#) [63-S](#) [M55155/059I03](#) [M55155/079C01](#) [M55155/099B03](#) [M55155/099H02](#) [M55155/109H01](#) [M55155/12XH05](#) [M55155/29-5S](#) [M55155/29XJ08](#) [M55155/30-6S](#) [M55155/30-9S](#) [M55155/30XI09](#) [M6-14RSX](#) [696683-1](#) [696861-1](#) [696999-1](#) [M86700006](#) [D18-110B-C](#) [D18-110B-M](#) [701-1936](#) [701-1955](#) [701-2003](#)