

# Specifications

Drawing No.	USY1M-H1-16426-00 1 / 11
Issued Date.	Apr,20,2016

## Messrs: KED USA

**Note: Part Number will be revised in case of specification change.**

Product Type	Quartz Crystal
Series	CX2016DB
Frequency	Refer to Doc No.USY1M-H1-16426-00 Page 3/11
Customer Part Number	-
Customer Specification Number	-
KYOCERA Part Number	Refer to Doc No.USY1M-H1-16426-00 Page 3/11
Remarks	Pb-Free, RoHS Compliant, MSL 1

### Customer Approval

Approval Signature	Approved Date	
	Department	
	Person in charge	

### Seller

**KYOCERA Crystal Device Corporation**  
(Sales Division)  
6 Takeda Tobadono-cho, Fushimi-ku, Kyoto  
612-8501 Japan  
TEL. No. 075-604-3500  
FAX. No. 075-604-3501

### Manufacturer

**KYOCERA Crystal Device Corporation**  
Crystal Units Division  
5850, Higashine-Koh, Higashine-Shi, Yamagata  
999-3701 Japan  
TEL. No. 0237-43-5611  
FAX. No. 0237-43-5615

Design Department	Quality Assurance	Approved by	Checked by	Issued by
KYOCERA Crystal Device Corporation Crystal Unit Application Engineering Section Crystal Units Division	S.Itoh	T.Soda	A.Muraoka	Y.Nozaki

### Revision History

Rev.No.	Description of revise	Date	Approved by	Checked by	Issued by
00	First Edition	Apr,20,2016	T.Soda	A.Muraoka	Y.Nozaki

[Parts Number list]

Nominal Frequency (MHz)	KYOCERA Part Number	ESR ( $\Omega$ )	Nominal Frequency Code
16.000	CX2016DB16000H0FLJC1	200	16000
19.200	CX2016DB19200H0FLJC2	150	19200
20.000	CX2016DB20000H0FLJC1	150	20000
24.000	CX2016DB24000H0FLJC4	150	24000
24.576	CX2016DB24576H0FLJC1	150	24576
25.000	CX2016DB25000H0FLJC1	150	25000
26.000	CX2016DB26000H0FLJC2	60	26000
27.000	CX2016DB27000H0FLJC1	60	27000
30.000	CX2016DB30000H0FLJC1	60	30000
32.000	CX2016DB32000H0FLJC1	60	32000
38.400	CX2016DB38400H0FLJC1	40	38400
40.000	CX2016DB40000H0FLJC1	40	40000
48.000	CX2016DB48000H0FLJC1	40	48000

## 1. APPLICATION

The purpose of this document is applied to CX2016DB quartz crystal.

## 2. KYOCERA PART NUMBER

Refer to Doc No.USY1M-H1-16426-00 Page 3/11

## 3. RATINGS

Items	SYMB.	Rating	Unit	Remarks
Operating Temperature range	Topr	-30~+85	deg. C	
Storage Temperature range	Tstg	-40~+85	deg. C	

## 4. CHARACTERISTICS

### 4-1 ELECTRICAL CHARACTERISTICS

Items	Electrical Specification					Test Condition	Remarks
	SYMB.	Min	Typ.	Max	Unit		
Mode of Vibration		Fundamental					
Nominal Frequency	F0		(*1)		MHz		
Nominal Temperature	T <sub>NOM</sub>		+25		°C		
Load Capacitance	CL		12.0		pF		
Frequency Tolerance	df/F	-10.0		+10.0	PPM	+25±3°C	
Frequency Temperature characteristics	df/F	-15.0		+15.0		-30°C ~+85°C	
Frequency Ageing Rate		-1.0		+1.0		1 <sup>ST</sup> year	+25±3°C
Equivalent Series Resistance	ESR		(*2)		Ω		
Drive Level	Pd	0.01		100	μW		
Insulation Resistance	IR	500			MΩ	100V(DC)	

### Measurement Condition

Frequency measurement

Measuring instrument : IEC PI-Network Test Fixture  
IEC 60444-8 STD (Pi circuit 41901A)

Equivalent series resistance (ESR) measurement

Measuring instrument : IEC PI-Network Test Fixture  
Load Capacitance : Series

\*1 \*2 Refer to Doc No.USY1M-H1-16426-00 Page 3/11

**5. APPEARANCES, PHYSICAL DIMENSION**  
**OUTLINE DIMENSION (not to scale)**

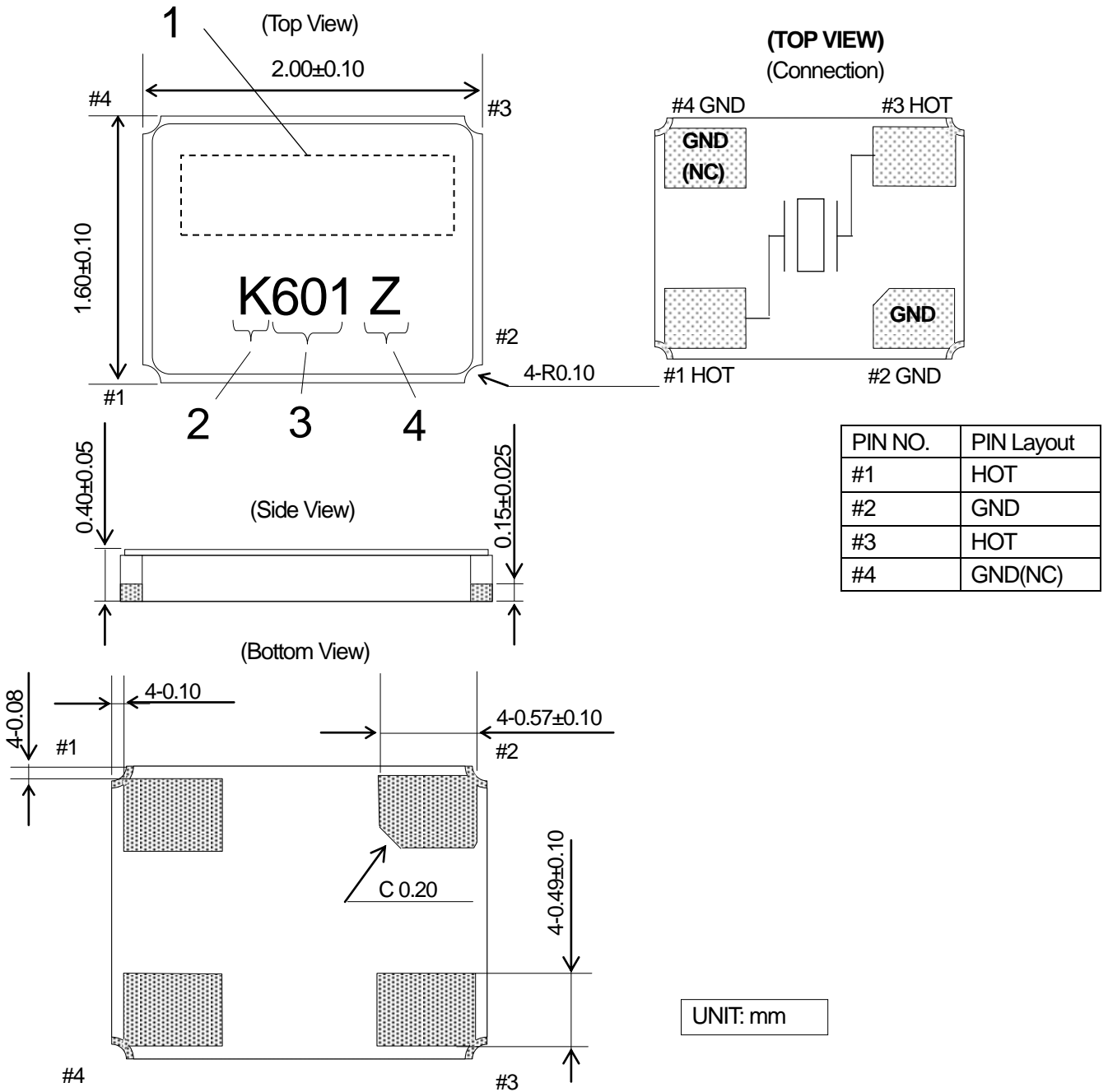

**MARKING**

- |   |                        |   |
|---|------------------------|---|
| 1 | Nominal Frequency      | First 5digit of the frequency is indicated. *3                |
| 2 | Identification         | [K] is to indicate 1Pin direction.                            |
| 3 | Date Code              | Last 1 Digit of YEAR and WEEK (Ex) 2016,Jan,01 → 601          |
| 4 | Manufacturing Location | Y→Japan (Yamagata)<br>Z→Japan (Shiga Yohkaichi)<br>T→Thailand |

\*The font of marking is for reference only.

\*3 Refer to Doc No.USY1M-H1-16426-00 Page 3/11

**6. RECOMMENDED LAND PATTERN (not to scale)**

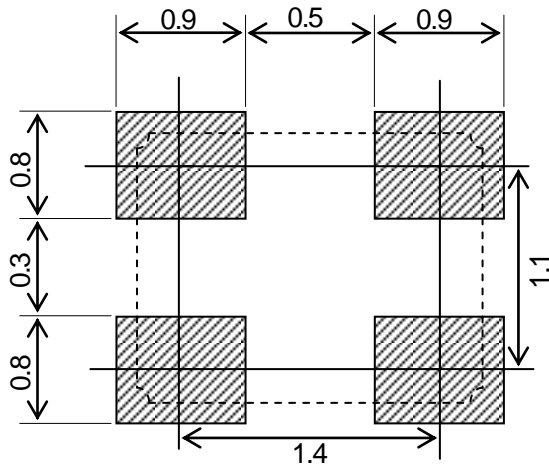

UNIT: mm

### 7. TAPING & REEL

#### 7-1. Dimensions

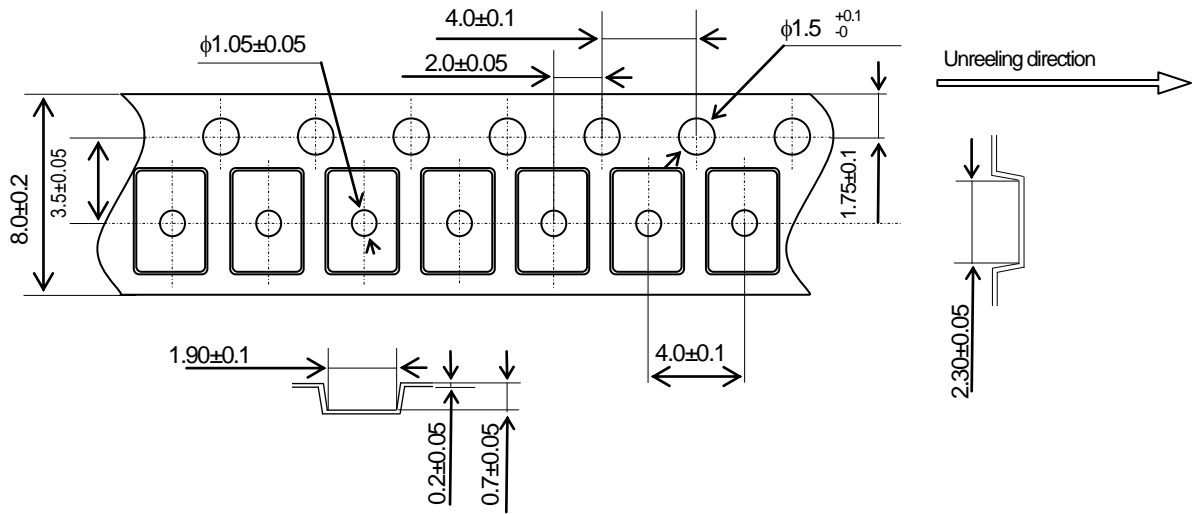

#### 7-2. Leader and Carrier tape

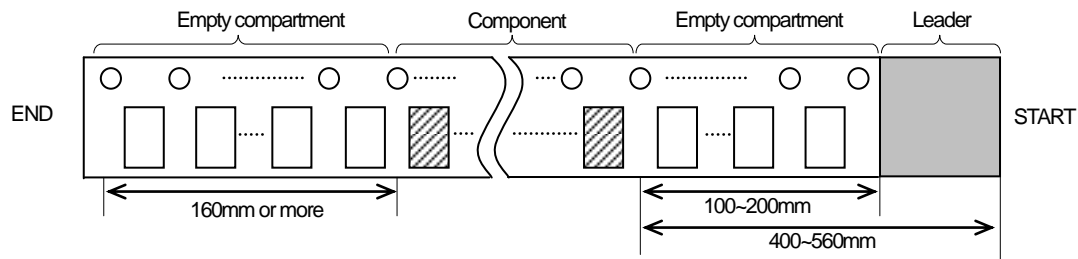

#### 7-3. Direction (Orientation shall be checked from the top cover tape side)



#### 7-4. Specification

1. Material of the carrier tape is either polystyrene or A-PET (ESD).
2. Material of the cover tape is polyester (ESD).
3. The seal tape shall not cover the sprocket holes and not protrude from the carrier tape.
4. Tensile strength of carrier tape: 10N or more.
5. The R of the corner of each cavity is 0.2RMAX.
6. The alignment between centers of the cavity and sprocket hole shall be 0.05mm or less.
7. The orientation shall be checked from the top cover tape side as shown in 7-3.
8. Peeling force of cover tape: 0.1 to 1.0N.
9. The component will fall out naturally when cover tape is removed and set upside down.

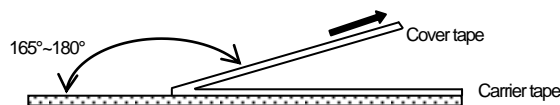

7-5.Reel Specification

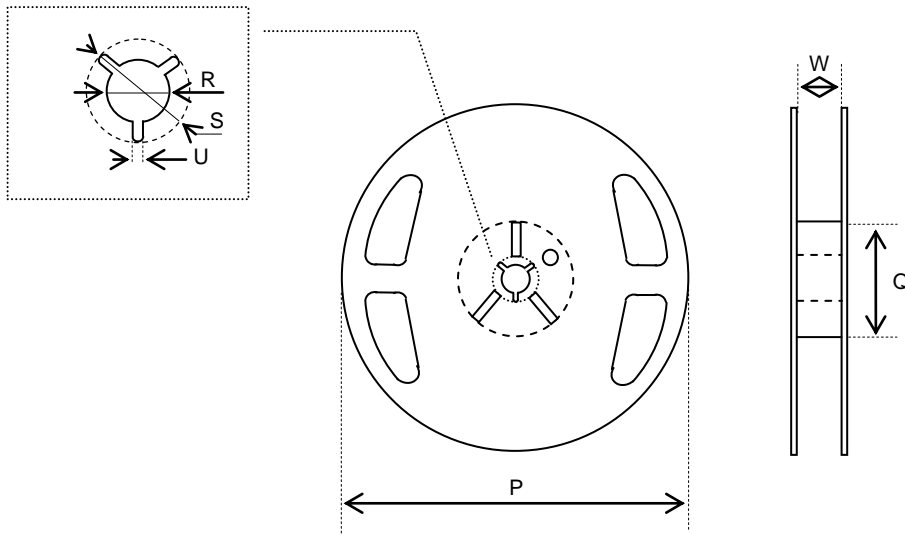

φ330 Reel (15,000 pcs Max.)

Symbol	P	Q	R
Dimension	φ330±2.0	φ100±1.0	φ13±0.2
Symbol	S	U	W
Dimension	φ21±0.8	2.0±0.5	9.4±1.0

(Unit: mm)



## 8. Environmental requirements

After conducting the following tests, component needs to meet below conditions.

Frequency: Fluctuation within  $\pm 10 \times 10^{-6}$

CI: Fluctuation within  $\pm 20\%$  or  $5\Omega$  whichever is larger

- 8.1 Resistance to Shock      Drop Test - test conditions  
Part is mounted to 200g fixture and dropped from a height of 150cm to a cement floor. The drop must be conducted on all 6 mutually perpendicular axes.
- Mechanical Shock Rating  
Peak Value 100g 6ms Half-Sine
- 8.2 Resistance to Vibration      Test condition
- |            |                               |
|------------|-------------------------------|
| frequency  | : 10 - 55 - 10 Hz             |
| Amplitude  | : 1.5mm                       |
| Cycle time | : 15 minutes                  |
| Direction  | : X,Y,Z (3direction),2h each. |
- 8.3 Resistance to Heat      Test condition  
The quartz crystal unit shall be stored at a temperature of  $+85\pm 2^\circ\text{C}$  for 500h and subjected to room temperature for 1h before measurement.
- 8.4 Resistance to Cold      Test condition  
The quartz crystal unit shall be stored at a temperature of  $-40\pm 2^\circ\text{C}$  for 500h and subjected to room temperature for 1h before measurement.
- 8.5 Thermal Shock      Test condition  
The quartz crystal unit shall be subjected to 500 temperature cycles shown in table below, Then it shall be subjected to room temperature for 1h before measurement.
- |       |  |
|-------|--|
| Cycle | : $-40\pm 2^\circ\text{C}$ (30min.) $\rightarrow$ $+25\pm 2^\circ\text{C}$ (5min.)             |
|       | $\rightarrow$ $+85\pm 2^\circ\text{C}$ (30min.) $\rightarrow$ $+25\pm 2^\circ\text{C}$ (5min.) |

8.6 Resistance to Moisture

Test condition

The quartz crystal unit shall be stored at a temperature of  $+60\pm 2^{\circ}\text{C}$  with relative humidity of 90% to 95% for 240 h. Then it shall be subjected to room temperature for 1h before measurement.

8.7 Soldering condition

1.) Type of solder

Material → lead free solder paste

Melting point →  $+220\pm 5^{\circ}\text{C}$

2.) Reflow temp.profile

	Temp [°C]	Time[sec]
Preheating	+150 to +180	150 (typ.)
Peak	$+260\pm 5$	10 (max.)
Total	-	300 (max.)

Frequency shift :  $\pm 2\text{ppm}$

3.) Hand Soldering  $+350^{\circ}\text{C}$  3 sec max

4.) Reflow Times 2 times in below Reflow temp. profile

Reflow temp.profile

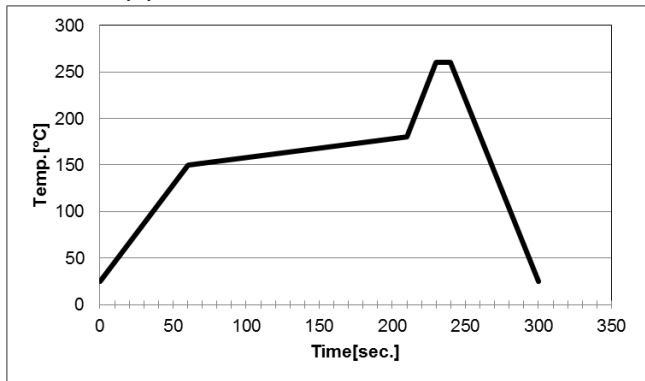

8.8 Bending Strength

Solder this product in center of the circuit board (40mm X 100mm), and add deflection of 3mm.

Test board :  $t=1.6\text{mm}$

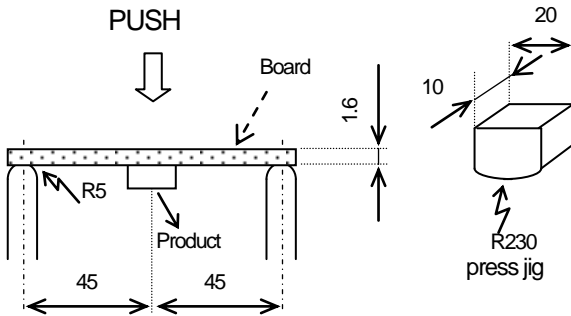

UNIT: mm

## 9. Cautions for use

### (1) Soldering upon mounting

There is a possibility to influence product characteristics when Solder paste or conductive glue comes in contact with product lid or surface.

### (2) When using mounting machine

Please minimize the shock when using mounting machine to avoid any excess stress to the product.

### (3) Conformity of a circuit

We strongly recommend to make sure that Negative resistance (Gain) of IC is designed to be 3 times the ESR (Equivalent Series Resistance) of crystal unit.

## 10. Storage conditions

Please store product in below conditions, and use within 6 months.

Temperature +18 to +30°C, and Humidity of 20 to 70 % in the packaging condition.

## 11. Manufacturing location

Kyocera Crystal Device Corporation Yamagata Plant

Kyocera Crystal Device Corporation Shiga Yohkaichi Plant

Kyocera Crystal Device (Thailand) Co., Ltd

## 12. Quality Assurance

To be guaranteed by Kyocera Crystal Device Quality Assurance Division

## 13. Quality guarantee

In case when Kyocera Crystal Device Corporation rooted failure occurred within 1year after its delivery, substitute product will be arranged based on discussion. Quality guarantee of product after 1year of its delivery is waived.

## 14. Others

In case of any questions or opinions regarding the Specification, please have it in written manner within 45 days after issued date.

## X-ON Electronics

Largest Supplier of Electrical and Electronic Components

*Click to view similar products for [Crystals](#) category:*

*Click to view products by [Kyocera AVX](#) manufacturer:*

Other Similar products are found below :

[MC405 32.0000K-R3:PURE SN](#) [7B-27.000MBBK-T](#) [MP1-8.0 99-BU](#) [9B-15.360MBBK-B](#) [PTX-A2JM-10.000M](#) [9C-7.680MBBK-T](#) [H10S-12.000-18-EXT-TR](#) [R38-32.768-12.5-5PPM-NPB](#) [BTD1062E05A-513](#) [21U15A-21.4MHZ](#) [RTX-781DF1-S-20.950](#) [LFXTAL066198Cutt](#) [9C-14.31818MBBK-T](#) [A-11.000MHZ-27](#) [SPT2A-.032768B](#) [SPT2A.032768G](#) [SSPT7F-9PF20-R](#) [FX325BS-38.88EEM1201](#) [MP-1-25.000MHZ-3L](#) [MP-1-6.000MHZ](#) [LFXTAL065253Cutt](#) [LFXTAL066431Cutt](#) [XT9S20ANA14M7456](#) [XT9SNLANA16M](#) [646G-24-2](#) [7A-24.576MBBK-T](#) [7B-30.000MBBK-T](#) [7A-14.31818MBBK-T](#) [6526-202-1501](#) [BTJ120E02C](#) [SG636PCE-20.000MC](#) [3404](#) [CM315D32768EZFT](#) [C1E-24.000-7-2020-R](#) [C1E-19.200-12-1530-X-R](#) [C1E-16.000-12-1530-X-R](#) [ABM11-16.000MHZ-9-B1U-T](#) [FL5000014](#) [EUCA18-3.1872M](#) [425F35E027M0000](#) [17196](#) [ABM3-13.52313MHZ-10-B4Y-T](#) [MS3V-T1R-32.768kHz-7pF-20PPM-TA-QC-Au](#) [VXM7-1C1-16M000](#) [MS1V-T1K-32.768kHz-10pF-20PPM-TA-QC-Au](#) [MS3V-T1R-32.768kHz-9pF-20PPM-TA-QC-Au](#) [ECS-80-18-30-JGN-TR](#) [17000](#) [17301](#)