

Specifications

Drawing No.	UKY1C-H1-16357-00[43] 1/12
Issued Date.	Apr,13,2016

TO: KED USA

Note: In case of specification change, KYOCERA Part Number also will be changed.

Product Name	Quartz Crystal
Product Model	CX3225SB
Frequency	Refer to UKY1C-H1-16357-00[43] 3/12 Nominal Frequency
Customer Part Number	-
Customer Specification Number	-
KYOCERA Part Number	Refer to UKY1C-H1-16357-00[43] 3/12 Nominal Frequency
Remarks	Pb-Free, RoHS Compliant, MSL 1

Customer Acceptance

Accept Signature	Approved Date	
	Department	
	Person in charge	

Seller

KYOCERA Crystal Device Corporation

(Sales Division)

6 Takeda Tobadono-cho, Fushimi-ku, Kyoto

612-8501 Japan

TEL. No. 075-604-3500

FAX. No. 075-604-3501

Manufacturer

Crystal Units Division

5850, Higashine-Koh, Higashine-Shi, Yamagata

999-3701 Japan

TEL. No. 0237-43-5611

FAX. No. 0237-43-5615

Design Department	Quality Assurance	Approved by	Checked by	Issued by
KYOCERA Crystal Device Corporation Crystal Units Engineering Section Crystal Units Division	T. Noritake	H. Shoji	T. Nitoube	Y. Kikuchi

Revision History

Rev.No.	Description of revise	Date	Approved by	Checked by	Issued by
1	First Edition	Apr,13,2016	H. Shoji	T. Nitoube	Y. Kikuchi

[PART NUMBER LIST]

Nominal Frequency (MHz)	KYOCERA Part Number	ESR (Ω)	Nominal Frequency Code
12.000	CX3225SB12000H0FLJCC	150	12000
12.288	CX3225SB12288H0FLJCC	150	12288
13.560	CX3225SB13560H0FLJCC	80	13560
16.000	CX3225SB16000H0FLJCC	80	16000
19.200	CX3225SB19200H0FLJCC	80	19200
20.000	CX3225SB20000H0FLJCC	50	20000
24.000	CX3225SB24000H0FLJCC	50	24000
24.576	CX3225SB24576H0FLJCC	50	24576
25.000	CX3225SB25000H0FLJCC	50	25000
26.000	CX3225SB26000H0FLJCC	50	26000
27.000	CX3225SB27000H0FLJCC	50	27000
30.000	CX3225SB30000H0FLJCC	50	30000
32.000	CX3225SB32000H0FLJCC	50	32000
38.400	CX3225SB38400H0FLJCC	50	38400
40.000	CX3225SB40000H0FLJCC	50	40000
48.000	CX3225SB48000H0FLJCC	50	48000
49.152	CX3225SB49152H0FLJCC	50	49152
54.000	CX3225SB54000H0FLJCC	50	54000

1. APPLICATION

This specification sheet is applied to quartz crystal "CX3225SB"

2. KYOCERA PART NUMBER

Refer to UKY1C-H1-16357-00[43] 3/12 KYOCERA Part Number

3. RATINGS

Items	SYMB.	Rating	Unit	Remarks
Operating Temperature	Topr	-30 to +85	°C	
Storage Temperature range	Tstg	-40 to +85	°C	

4. CHARACTERISTICS

ELECTRICAL CHARACTERISTICS

Items	Electrical Specification					Test Condition	Remarks
	SYMB.	Min	Typ.	Max	Unit		
Mode of Vibration		Fundamental					
Nominal Frequency	F0		※1		MHz		
Nominal Temperature	T _{NOM}		+25		°C		
Load Capacitance	CL	12.0			pF		
Frequency Tolerance	df/F	-10.0		+10.0	PPM	+25±3°C	
Frequency Temperature characteristics	df/F	-15.0		+15.0		-30 to +85°C	
Frequency Aging Rate		-1.0		+1.0		1 st year	+25±3°C
Equivalent Series Resistance	ESR			※2	Ω		
Drive Level	Pd	0.01		100	μW		
Insulation Resistance	IR	500			MΩ	100V(DC)	

※1 Refer to UKY1C-H1-16356-00[43] 3/12 Nominal Frequency

※2 Refer to UKY1C-H1-16356-00[43] 3/12 ESR

5. Measurement Condition

5.1 Frequency measurement

Measuring instrument : IEC PI-Network Test Fixture

Load Capacitance : 12.0pF

Drive Level : 10 μ W

5.2 Equivalent series resistance (ESR) measurement

Measuring instrument : IEC PI-Network Test Fixture

Load Capacitance : Series

Drive Level : 10 μ W

6. APPEARANCES, PHYSICAL DIMENSION
OUTLINE DIMENSION (not to scale)

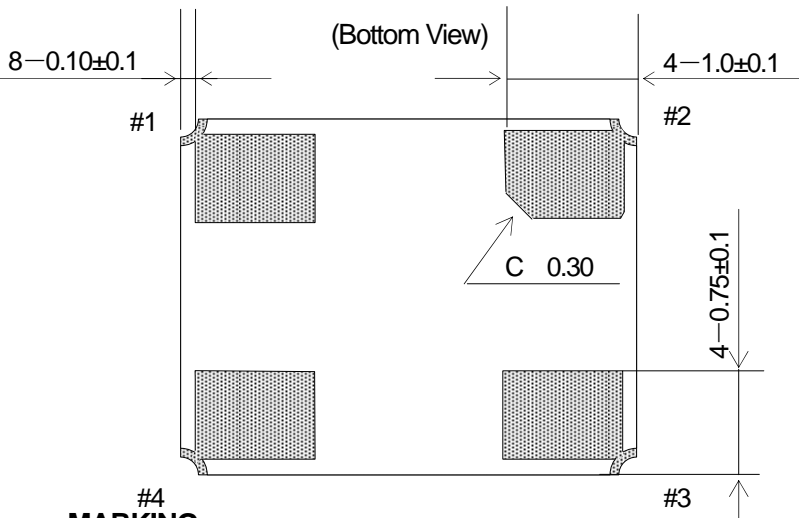
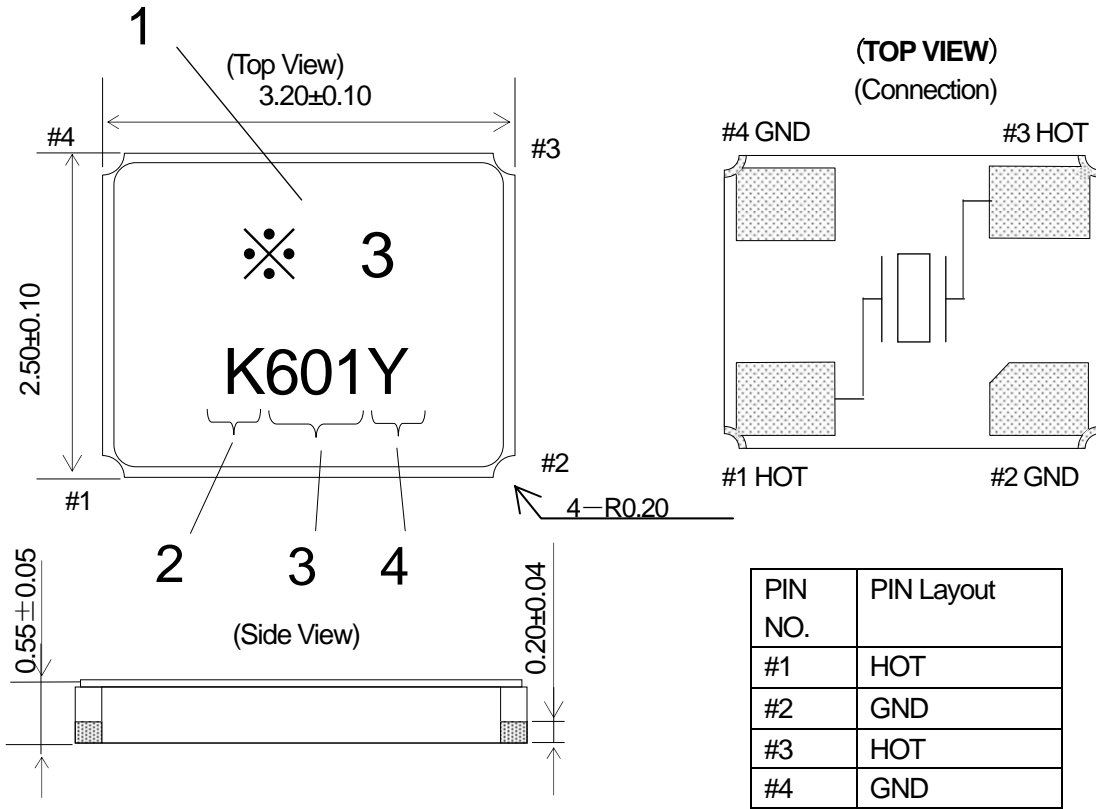

UNIT : mm

MARKING

- 1 Nominal Frequency Move the number of maximum indication beams of the frequency to five digits, and omit less than kHz.
- 2 Identification [K] mark is surely 1Pin direction.
- 3 Date Code Year··LAST 1 DIGIT of YEAR AND WEEK
(Ex)Jan, 01, 2016 → 601
- 4 Manufacturing Location
 Y··Japan(Yamagata)
 Z··Japan(Shiga Yohkaichi)
 T··Thailand

※3 Refer to UKY1C-H1-16357-00[43] 3/12 Nominal Frequency Code

※The font of marking is reference.

7. RECOMMENDED LAND PATTERN (not to scale)

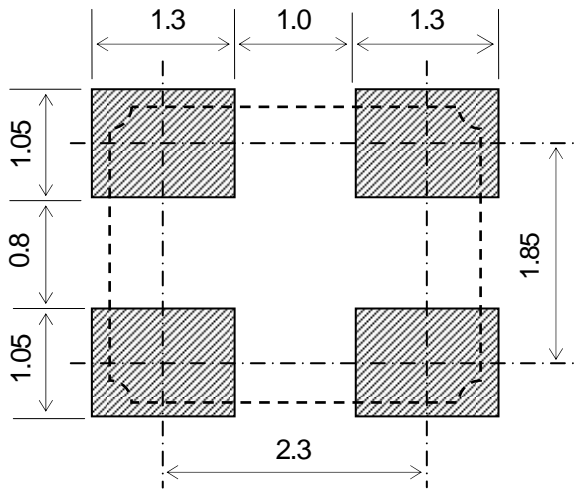

UNIT : mm

8.TAPING & REEL

8-1.Dimensions

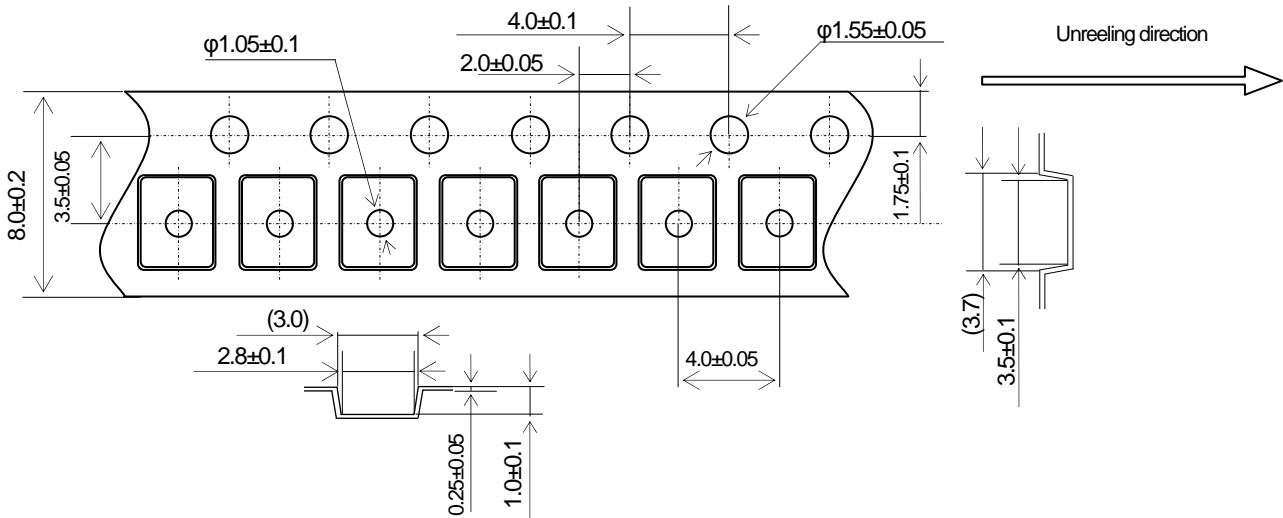

8-2.Leader and trailer tape

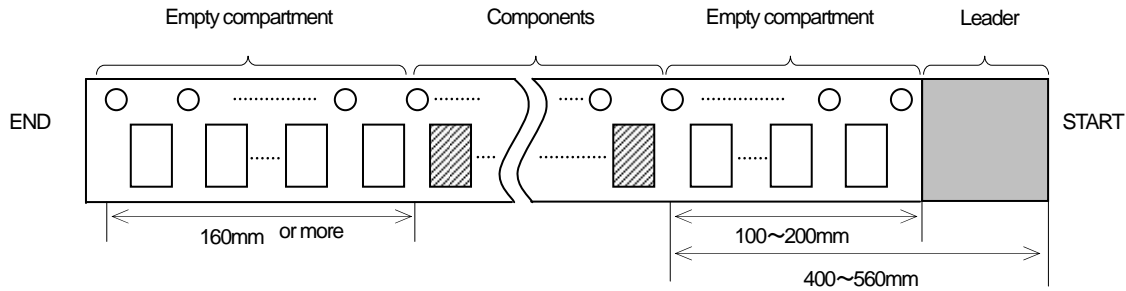

8-3.Direction (The direction shall be seen from the top cover tape side)

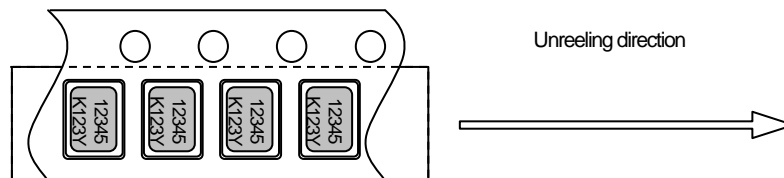

8-4.Specification

1. Material of the carrier tape is either polystyrene or A-PET (ESD).
2. Material of the cover tape is polyester (ESD).
3. The seal tape shall not cover the sprocket holes and not protrude from the carrier tape.
4. Tensile strength of carrier tape: 10N or more.
5. The R of the corner of each cavity is 0.2RMAX.
6. The alignment between centers of the cavity and sprocket hole shall be 0.05mm or less.
7. The orientation shall be checked from the top cover tape side as shown in 8-3.
8. Peeling force of cover tape: 0.1 to 1.0N.
9. The component will fall out naturally when cover tape is removed and set upside down.

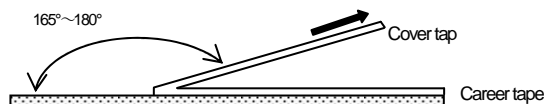

8-5.Reel Specification

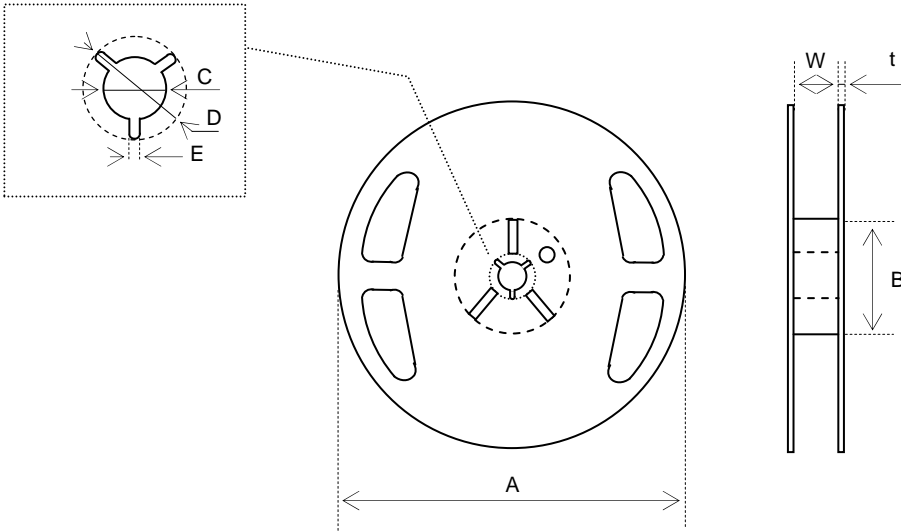

l

m)

In the case of $\Phi 180$ Reel (3,000 pcs max, every 1,000 pcs)

Symbol	A	B	C	D
Dimension	$\phi 180 +0/-3$	$\phi 60 +1/-0$	$\phi 13 \pm 0.2$	$\phi 21 \pm 0.8$
Symbol	E	W	t	
Dimension	2.0 ± 0.5	9 ± 1	2.0 ± 0.5	

(Unit : mm)

In the case of $\Phi 330$ Reel (10,000 pcs max, every 1,000 pcs)

Symbol	A	B	C	D
Dimension	$\phi 330 \pm 2.0$	$\phi 100 \pm 1.0$	$\phi 13 \pm 0.2$	$\phi 21 \pm 0.8$
Symbol	E	W	t	
Dimension	2.0 ± 0.5	9.5 ± 0.5	2.2 ± 0.1	

(Unit : m)

9.6 Resistance to Moisture

Test condition

The quartz crystal unit shall be stored at a temperature of $+60 \pm 2^\circ\text{C}$ with relative humidity of 90% to 95% for 240 h. Then it shall be subjected to standard atmospheric conditions for 1h, after which measurements shall be made

9.7 Soldering condition

1.) Material of solder

Kind ... lead free solder paste

Melting point ... $+220 \pm 5^\circ\text{C}$

2.) Reflow temp.profile

	Temp [$^\circ\text{C}$]	Time[sec]
Preheating	+150 to +180	150 (typ.)
Peak	$+260 \pm 5$	10 (max.)
Total	—	300 (max.)

Frequency shift : $\pm 2\text{ppm}$

3.) Hand Soldering + 350°C 3 sec MAX

4.) Reflow Times 2 times

Reflow temp.profile

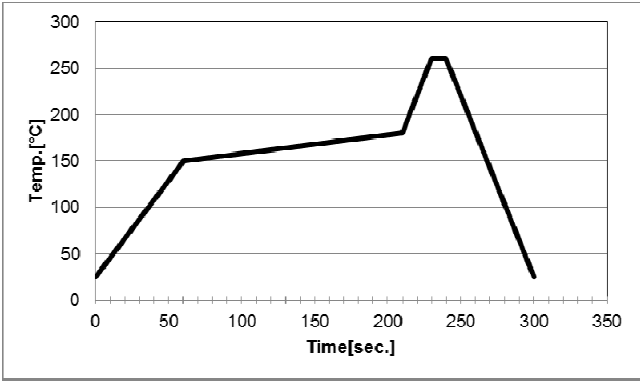

9.8 Intensity for bending in circuit board

Solder this product in center of the circuit board of $40\text{mm} \times 100\text{mm}$, and add the deflection of 3mm as the bottom figure.

Test board : $t = 1.6\text{mm}$

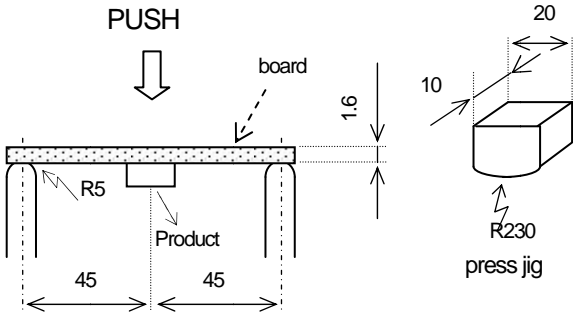

UNIT : mm

10. Cautions for use

(1) Soldering upon mounting

There is a possibility to influence product characteristics when Solder paste or conductive glue comes in contact with product lid or surface.

(2) When using mounting machine

Please minimize the shock when using mounting machine to avoid any excess stress to the product.

(3) Conformity of a circuit

We strongly recommend to make sure that Negative resistance (Gain) of IC is designed to be 5 times the ESR (Equivalent Series Resistance) of crystal unit.

11. Storage conditions

Please store product in below conditions, and use within 6 months.

Temperature +18 to +30°C, and Humidity of 20 to 70 % in the packaging condition.

12. Manufacturing location

Kyocera Crystal Device Corporation / Japan(Yamagata)

Kyocera Crystal Device Corporation Shiga Yohkaichi Plant / Japan(Shiga)

Kyocera Crystal Device (Thailand) Co., Ltd / Thailand(Lamphun)

13. Quality Assurance

To be guaranteed by Kyocera Crystal Device Quality Assurance Division

14. Quality guarantee

In case when Kyocera Crystal Device Corporation rooted failure occurred within 1year after its delivery, substitute product will be arranged based on discussion. Quality guarantee of product after 1year of its delivery is waived.

15. Others

In case of any questions or opinions regarding the Specification, please have it in written manner within 45 days after issued date.

X-ON Electronics

Largest Supplier of Electrical and Electronic Components

Click to view similar products for [Crystals](#) category:

Click to view products by [Kyocera AVX](#) manufacturer:

Other Similar products are found below :

[MC405 32.0000K-R3:PURE SN](#) [7A-40.000MAAE-T](#) [MP1-8.0](#) [99-BU](#) [9B-15.360MBBK-B](#) [PTX-A2JM-10.000M](#) [9C-7.680MBBK-T](#) [H10S-12.000-18-EXT-TR](#) [AB-11.0592MHZ](#) [R38-32.768-12.5-5PPM-NPB](#) [BTD1062E05A-513](#) [C711980XFAS30XX](#) [21U15A-21.4MHZ](#) [RTX-781DF1-S-20.950](#) [LFXTAL066198Cutt](#) [9C-14.31818MBBK-T](#) [A-11.000MHZ-27](#) [SPT2A-.032768B](#) [SPT2A.032768G](#) [SSPT7F-9PF20-R](#) [FX325BS-38.88EEM1201](#) [MP-1-25.000MHZ-3L](#) [MP-1-6.000MHZ](#) [LFXTAL065253Cutt](#) [LFXTAL066431Cutt](#) [XT9S20ANA14M7456](#) [XT9SNLANA16M](#) [646G-24-2](#) [7A-24.576MBBK-T](#) [7B-30.000MBBK-T](#) [7A-14.31818MBBK-T](#) [6526-202-1501](#) [BTJ120E02C](#) [SG636PCE-20.000MC](#) [ABM3B-10.000MHZ-K-T](#) [3404](#) [CM315D32768EZFT](#) [C1E-24.000-7-2020-R](#) [C1E-19.200-12-1530-X-R](#) [C1E-16.000-12-1530-X-R](#) [ABM11-16.000MHZ-9-B1U-T](#) [FL5000014](#) [EUCA18-3.1872M](#) [425F35E027M0000](#) [17196](#) [MS3V-T1R-32.768kHz-7pF-20PPM-TA-QC-Au](#) [VXM7-1C1-16M000](#) [MS1V-T1K-32.768kHz-10pF-20PPM-TA-QC-Au](#) [MS3V-T1R-32.768kHz-9pF-20PPM-TA-QC-Au](#) [ECS-80-18-30-JGN-TR](#)