



RoHS Compliant

Features

- 0402 Size. Rated current up to 2A MAX.
- Effective for filtering noise on power (Vcc) lines.

Applications

- PCs, Laser Printers, Cellular Phone, Power/ Signal Lines for LCD Display, Office Equipments
- AV Power Supply/ Signal Line, TV, VCR, etc.
- High Current Signal Lines

How to Order

KNH 10 C104 DA 20T S
① ② ③ ④ ⑤ ⑥

① Series

② Size Code

10	1005 (EIA:0402)
-----------	-----------------

③ Capacitance

C474	470,000pF	C104	100,000pF
C224	220,000pF		

④ Application

DA	Digital Circuit in General
-----------	----------------------------

⑤ Packaging

20T	T&R: 20,000 pcs. (Std.)
------------	-------------------------

⑥ Termination

S	Std.
----------	------

Dimensions

(Unit: mm)

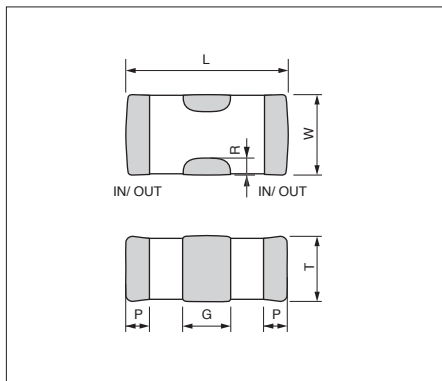

CODE	L	W	T
Dimensions	1.00±0.10	0.50±0.10	0.35±0.05
CODE	G	P	R
Dimensions	0.30±0.05	0.15±0.075	≥0.01

Specifications

Part Number	Capacitance (+50/ -20%)	Rated Current	Rated Voltage	Temp. Coefficient of Capacitance	Operating Temperature
KNH10C474DA20TS	470,000pF	2.0A	10VDC	±15%	-40 to +85°C
KNH10C224DA20TS	220,000pF	2.0A	10VDC	±15%	
KNH10C104DA20TS	100,000pF	2.0A	10VDC	±15%	

• Storage condition
Temperature: -10 to +45°C
Humidity: 45 to 75%RH

Attenuation Characteristics

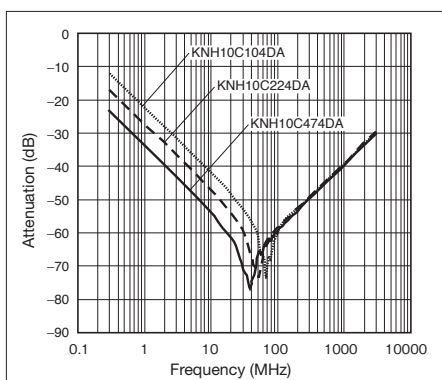

Recommended Land Pattern

(Unit: mm)

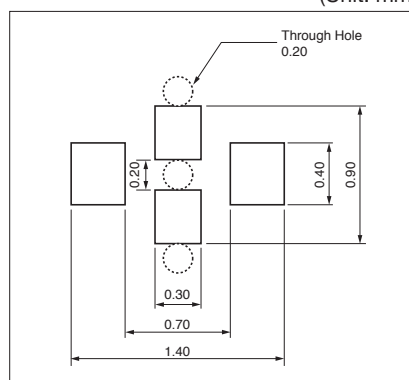

Packaging Specification

• Taping (20,000/ reel)

(Unit: mm)

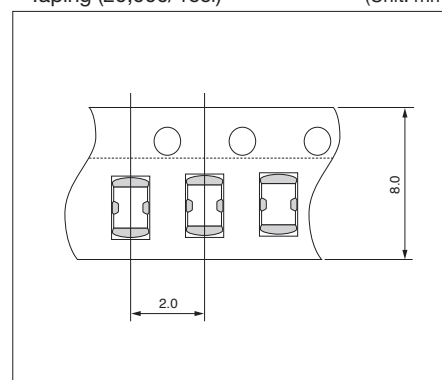



RoHS Compliant

Features

- 0603 Size. Rated current up to 2A MAX.
- Effective for filtering noise on power (Vcc) lines.

Applications

- PCs, Laser Printers, Cellular Phone, Power/ Signal Lines for LCD Display, Office Equipments
- AV Power Supply/ Signal Line, TV, VCR, etc.
- High Current Signal Lines

How to Order

KNH 16 C104 DA 5T S
 ① ② ③ ④ ⑤ ⑥

① Series	
② Size Code	16 1608 (EIA: 0603)
③ Capacitance	C105 1,000,000pF C104 100,000pF
④ Application	DA Digital Circuit in General (Std. Type) DB Digital Circuit in General (High Att. Type)
⑤ Packaging	5T T&R: 5000 pcs. (Std.)
⑥ Termination	S Std.

Specifications

Part Number	Capacitance (+50/ -20%)	Rated Current	Rated Voltage	Temp. Coefficient of Capacitance	Operating Temperature
KNH16C105DB5TS	1,000,000pF	2.0A	10VDC	±15%	-40 to +85°C
KNH16C104DA5TS	100,000pF	2.0A	25VDC	±15%	

• Storage condition
 Temperature: -10 to +45°C
 Humidity: 45 to 75%RH

Dimensions

(Unit: mm)

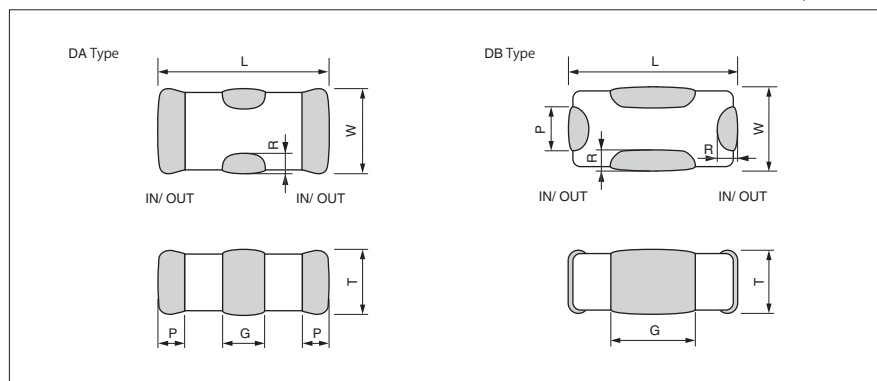

CODE	L	W	T
KNH16	1.60±0.10	0.80±0.10	0.60±0.10
CODE	G	P	R
DA Type	0.40±0.10	0.25±0.10	≥0.01
DB Type	0.85±0.15	0.40±0.10	≥0.01

Attenuation Characteristics

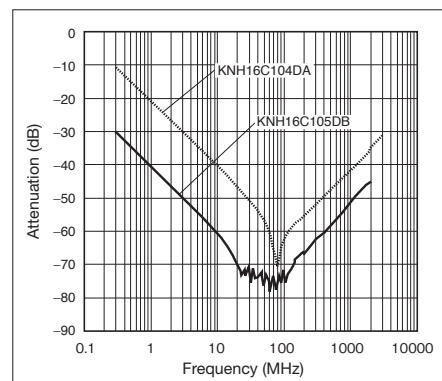

Recommended Land Pattern

(Unit: mm)

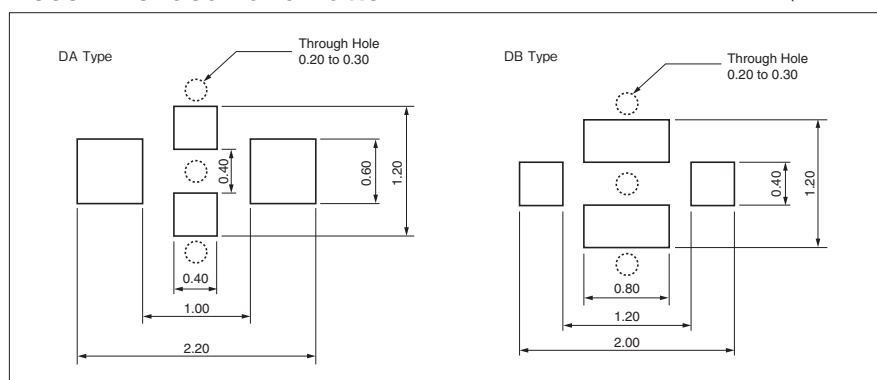

Packaging Specification

- Taping (5,000/ reel) (Unit: mm)

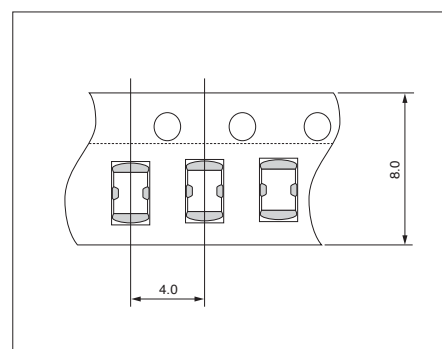

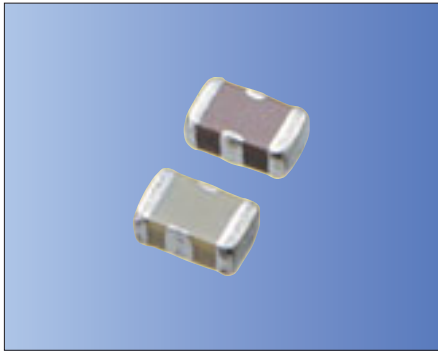

RoHS Compliant

Features

- 0805 Size. Rated current up to 6A MAX.
- Effective for filtering noise on power (Vcc) lines.

Applications

- PCs, Laser Printers, Cellular Phone, Power/ Signal Lines for LCD Display, Office Equipments
- AV Power Supply/ Signal Line, TV, VCR, etc.
- High Current Signal Lines

How to Order

KNH 21 C104 DA 3T S
① ② ③ ④ ⑤ ⑥

① Series

② Size Code

21	2012 (EIA: 0805)
-----------	------------------

③ Capacitance

C106	10,000,000pF	C473	47,000pF
C105	1,000,000pF	C471	470pF
C104	100,000pF	C221	220pF

④ Application

DA	Digital Circuit in General
-----------	----------------------------

⑤ Packaging

3T	T&R: 3000 pcs. (Std.)
-----------	-----------------------

⑥ Termination

S	Std.
----------	------

Dimensions

(Unit: mm)

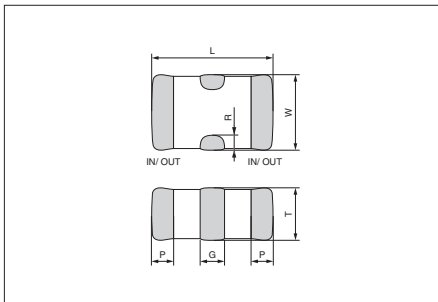

CODE	L	W
KNH21	2.0±0.2	1.25±0.2
CODE	T	G
KNH21	0.85±0.15	0.40±0.30
CODE	P	R
KNH21	0.30±0.20	≥0.01

Specifications

Part Number	Capacitance (+50/-20%)	Rated Current	Rated Voltage	Temp. Coefficient of Capacitance	Operating Temperature
KNH21C106DA3TS	10,000,000pF	6.0A	6.3VDC	±15%	-40 to +85°C
KNH21C105DA3TS	1,000,000pF	4.0A	10VDC	±15%	
KNH21C104DA3TS	100,000pF	2.0A	25VDC	±15%	
KNH21C473DA3TS	47,000pF	2.0A	50VDC	±15%	
KNH21C471DA3TS	470pF	1.0A	50VDC	±60ppm/°C	
KNH21C221DA3TS	220pF	1.0A	50VDC	±60ppm/°C	

• Storage condition
Temperature: -10 to +45°C
Humidity: 45 to 75%RH

Attenuation Characteristics

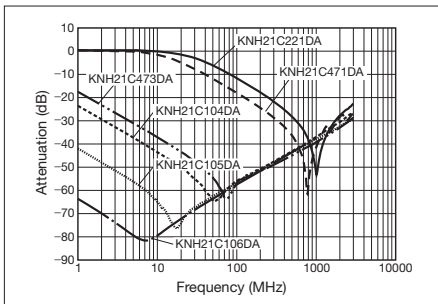

Recommended Land Pattern

(Unit: mm)

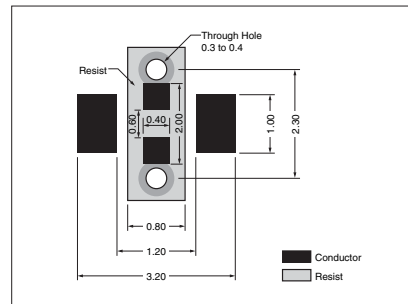

Packaging Specification

• Taping (3000/ reel)

(Unit: mm)

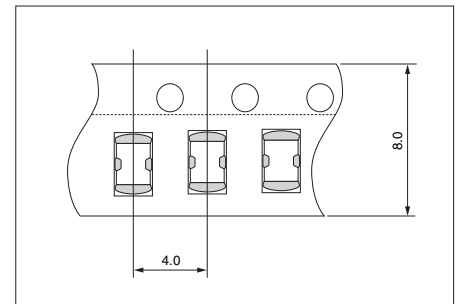

<Electrical Characteristics>

- Wide attenuation range including surrounding circuit.

Test Circuit

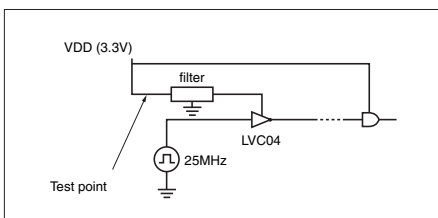

Attenuation Effect of Power Supply Noise

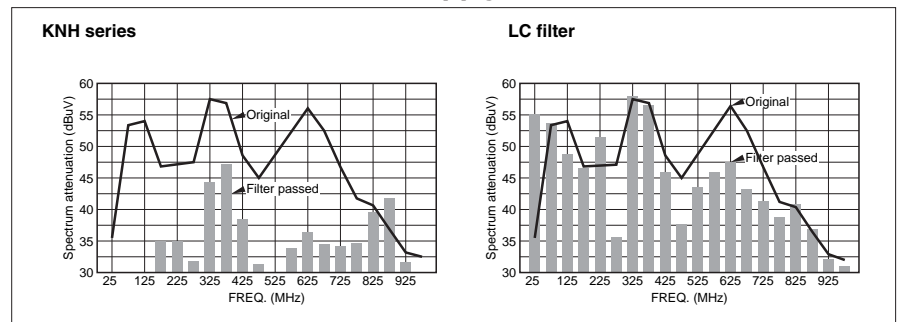

X-ON Electronics

Largest Supplier of Electrical and Electronic Components

Click to view similar products for [Feed Through Capacitors](#) category:

Click to view products by [Kyocera AVX](#) manufacturer:

Other Similar products are found below :

[PSM4-402Z-20B](#) [CKD110JB1E470S](#) [CKD510JB1E473S](#) [CKD510JB1H221S](#) [CKD510JB1H470S](#) [4700-003MLF](#) [4700-053LF](#) [4701-001MLF](#) [4701-002MLF](#) [SSM1-402E-10B](#) [SSM1-501P-10T1](#) [SSM1-402E-10T1](#) [SSM1-152P-05T1](#) [4700-009MLF](#) [SSM1-101Z-05B](#) [SSM1F-402E-10T1](#) [SSM1-202P-05T1](#) [0805J0500471MATE03](#) [PSM4-103Z-20T0](#) [0805J1000470MATE03](#) [SF0603C101SBNBB](#) [PSM4F-402Z-20T0](#) [CX0603MRX7R6BB104](#) [CX1206MKX7R9BB104](#) [CX0603MRX7R9BB103](#) [YFF15PC0J105MT000N](#) [NFM15CC222D1A3D](#) [NFM15CC223C1C3D](#) [NFM15CC223C1A3D](#) [NFM18PC225B1A3D](#) [CX0603MRX5R6BB224](#) [CX0603MRX7R9BB103](#) [CX0805MRX7R0BB103](#) [CX0805MRX7R8BB223](#) [CX1206MKX7R7BB224](#) [CX1206MKX7R9BB104](#) [NFM31HK104R1H3L](#) [NFM31HK223R1H3L](#) [NFM15PC224R1A3D](#) [DSS1NB32A223Q91A](#) [DSS1NB31H104Q91A](#) [NFE31PT101C1E9L](#) [NFE31PT220R1E9L](#) [NFE61PT330B1H9L](#) [NFE61PT681B1H9L](#) [NFM31KC104R1H3L](#) [NFM41CC223R2A3L](#) [DSS1NB32A103Q91A](#) [DSS1NB32A102Q91A](#) [NFE31PT471F1E9L](#)