

□ 回路図 : CIRCUIT

□ 概略図 : SCHEMATIC DIAGRAM

Dimension: [mm]

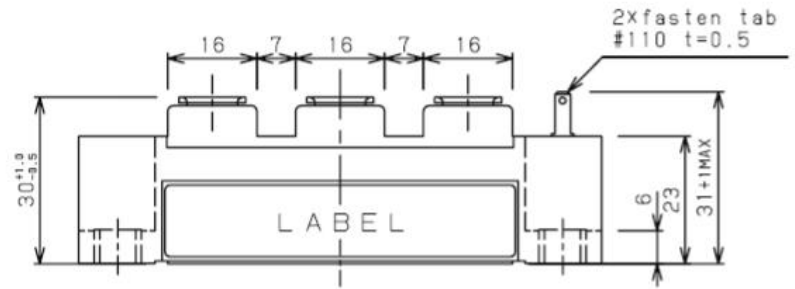
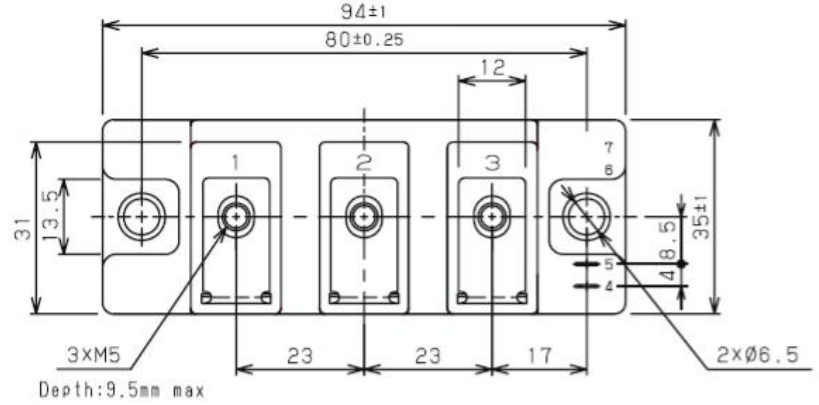
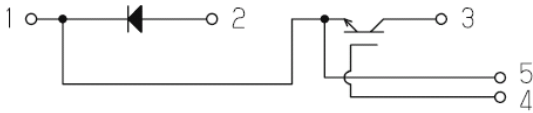

□ 最大定格 : MAXIMUM RATINGS (at Tc=25°C unless otherwise specified)

Item		Symbol	Condition	Rated Value	Unit
IGBT	コレクタ・エミッタ間電圧 Collector-Emitter Voltage	V _{CES}	G-E Short	1200	V
	ゲート・エミッタ間電圧 Gate-Emitter Voltage	V _{GES}	C-E Short	±20	V
	コレクタ電流 Collector Current	I _C	DC T _c =85°C	75	A
		I _{CP}	Pulse ≤ 1ms	150	
コレクタ損失 Collector Power Dissipation	P _C	T _j =175°C	348	W	
		T _j =150°C	290		
Diode	繰り返しピーク逆電圧 Repetitive peak reverse voltage	V _{RRM}		1200	V
	順電流 Forward Current	I _F		75	A
		I _{FM}	Pulse ≤ 1ms	150	
最大接合温度 Maximum Junction Temperature		T _{jMAX}	瞬時動作(過負荷) Instantaneous Overload	175	°C
接合温度範囲 Junction Temperature Range		T _j		-40~+150	°C
保存温度範囲 Storage Temperature Range		T _{stg}		-40~+125	°C
絶縁耐圧 Isolation Voltage		V _{ISO}	Terminal to Base AC, 1minute	2,500	V (RMS)
締め付けトルク Mounting Torque	Module Base to Heatsink	F _{tor}	M6	3	N・m
	Busbar to Main Terminal		M5	2	

□ 電 氣 的 特 性 : **ELECTRICAL CHARACTERISTICS** (at $T_j=25^\circ\text{C}$ unless otherwise specified)

Characteristic		Symbol	Test Condition	Min.	Typ.	Max.	Unit	
IGBT	コレクタ遮断電流 Collector-Emitter Cut-Off Current	I_{CES}	$V_{CE}=1200V, V_{GE}=0V$	—	—	1.0	mA	
	ゲート漏れ電流 Gate-Emitter Leakage Current	I_{GES}	$V_{GE}=\pm 20V, V_{CE}=0V$	—	—	1.0	μA	
	コレクタ・エミッタ間飽和電圧 Collector-Emitter Saturation Voltage	$V_{CE(sat.)}$	$I_c=75A, V_{GE}=15V$ (chip level)	$T_j=25^\circ\text{C}$	—	1.50	2.00	V
				$T_j=125^\circ\text{C}$	—	1.70	—	
				$T_j=150^\circ\text{C}$	—	1.80	—	
	ゲートしきい値電圧 Gate-Emitter Threshold Voltage	$V_{GE(th.)}$	$V_{CE}=10V, I_c=2.5mA$	4.8	—	7.0	V	
	入力容量 Input Capacitance	C_{ies}	$V_{CE}=25V, V_{GE}=0V, f=1MHz$	—	8.0	—	nF	
	出力容量 Output Capacitance	C_{oes}		—	0.23	—		
	帰還容量 Reverse Transfer Capacitance	C_{res}		—	0.20	—		
	ゲート電荷量 Gate Charge	Q_g	$V_{CC}=600V, I_c=75A, V_{GE}=-15\sim+15V$	—	830	—	nC	
スイッチング時間 Switching Time	上昇時間 Rise Time	t_r	$V_{CC}=600V, L_s=38nH$ $I_c=75A$ Inductive Load $R_g=10\Omega$ $V_{GE}=\pm 15V$ $T_j=150^\circ\text{C}$	—	60	—	ns	
	ターンオン遅延時間 Turn-on Delay Time	$t_d(on)$		—	110	—		
	下降時間 Fall Time	t_f		—	180	—		
	ターンオフ遅延時間 Turn-off Delay Time	$t_d(off)$		—	500	—		
Diode	順電圧 Peak Forward Voltage	V_F	$I_F=75A, V_{GE}=0V$ (chip level)	$T_j=25^\circ\text{C}$	—	2.00	2.60	V
	逆回復時間 Reverse Recovery Time	t_{rr}		$T_j=125^\circ\text{C}$	—	1.98	—	
$T_j=150^\circ\text{C}$				—	1.95	—		
			$V_{CC}=600V, L_s=38nH$ $I_c=75A$ Inductive Load $R_g=10\Omega$ $V_{GE}=\pm 15V$ $T_j=150^\circ\text{C}$	—	150	—	ns	
内部配線抵抗 Internal Lead Resistance		R_{CC+EE}	主端子—チップ間 / 1素子 Main Terminal - Chip / Per 1 Arm	—	—	1	$m\Omega$	
内部インダクタンス Stray Inductance		L_{SCE}	メイン端子3—2間 Main Terminal 3 - Main Terminal 2	—	30	—	nH	

 □ 熱 的 特 性 : **THERMAL CHARACTERISTICS**

Characteristic		Symbol	Test Condition	Min.	Typ.	Max.	Unit
熱 抵 抗 Thermal Resistance	IGBT	$R_{th(j-c)}$	Junction to Case Per 1 Arm (T _c 測定点:チップ直下)	—	—	0.43	$^\circ\text{C}/\text{W}$
	Diode			—	—	0.80	
接 触 熱 抵 抗 Thermal Resistance	IGBT	$R_{th(c-f)}$	Case to heatsink Per 1 Arm Paste=1W/(m ² ·°C)	—	0.10	—	
	Diode			—	0.17	—	

特性图 : CHARACTERISTICS CURVES

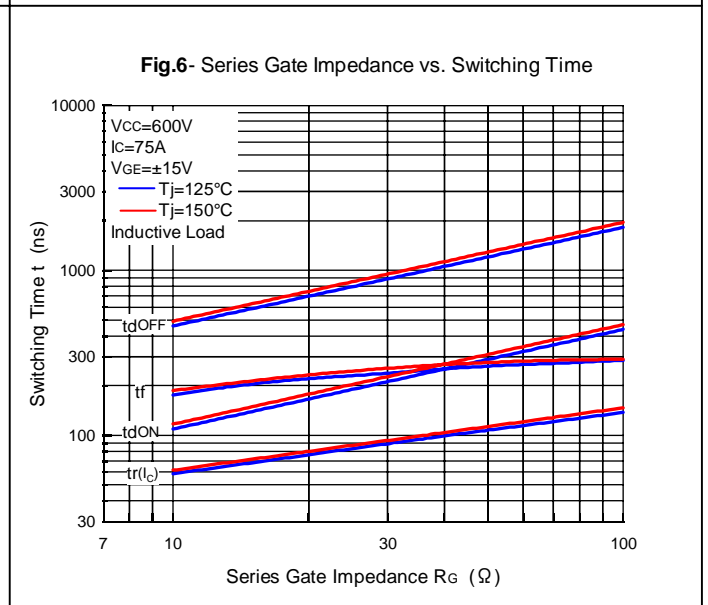
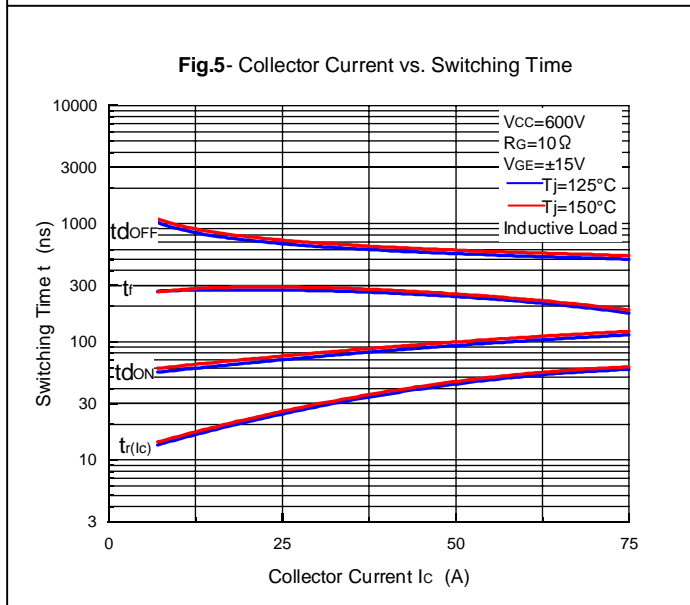
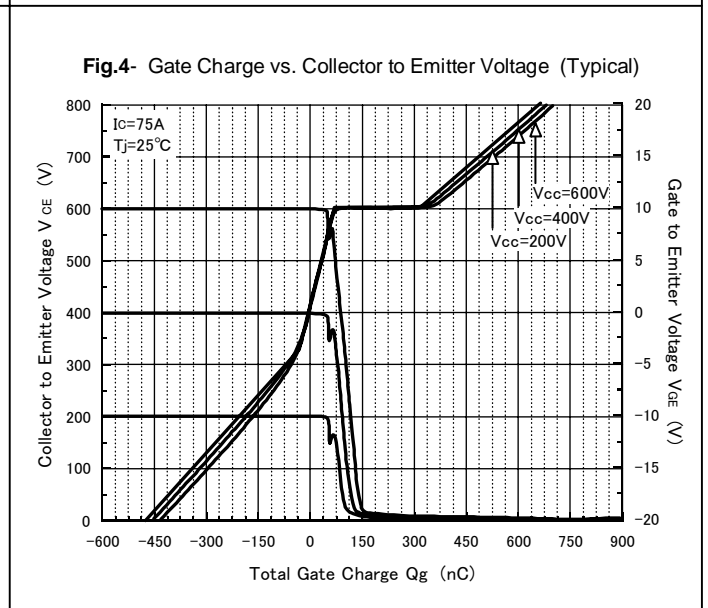
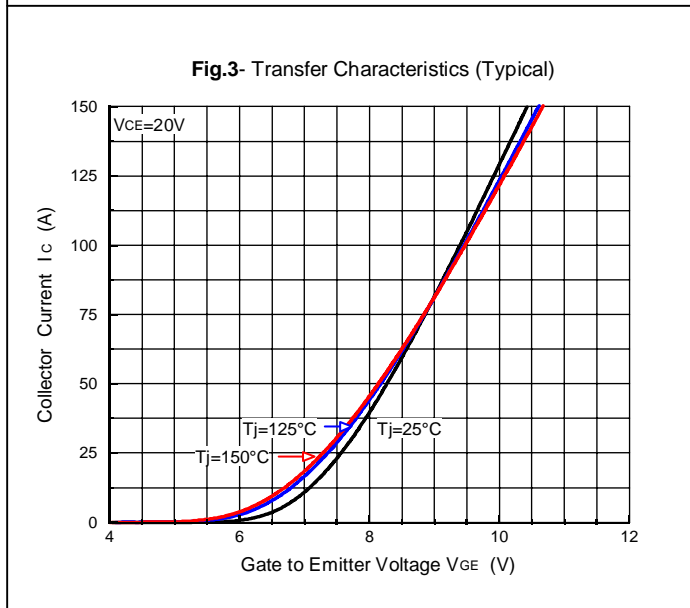
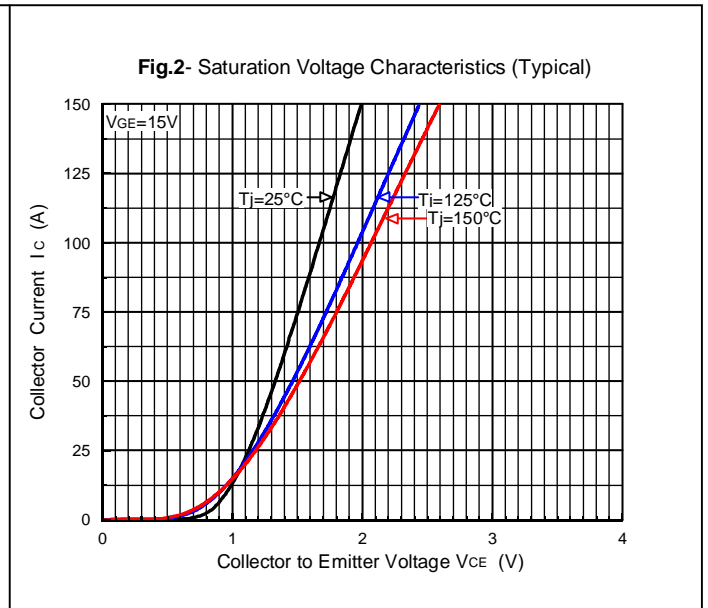
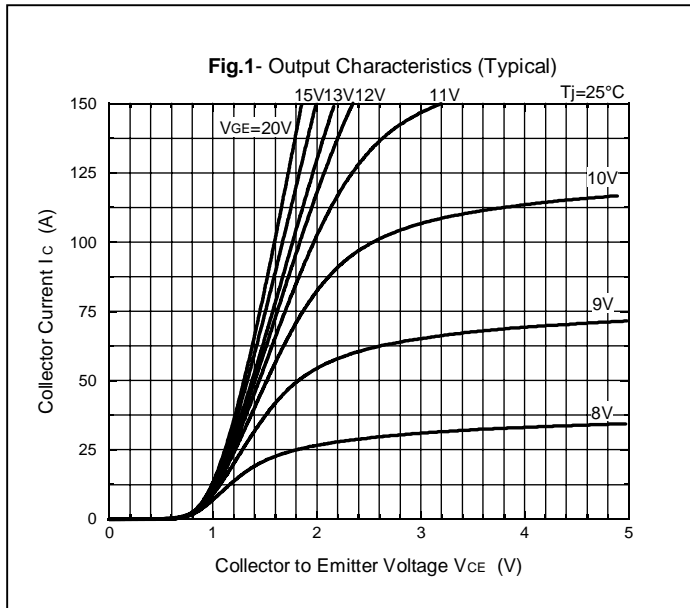

特図 : CHARACTERISTICS CURVES

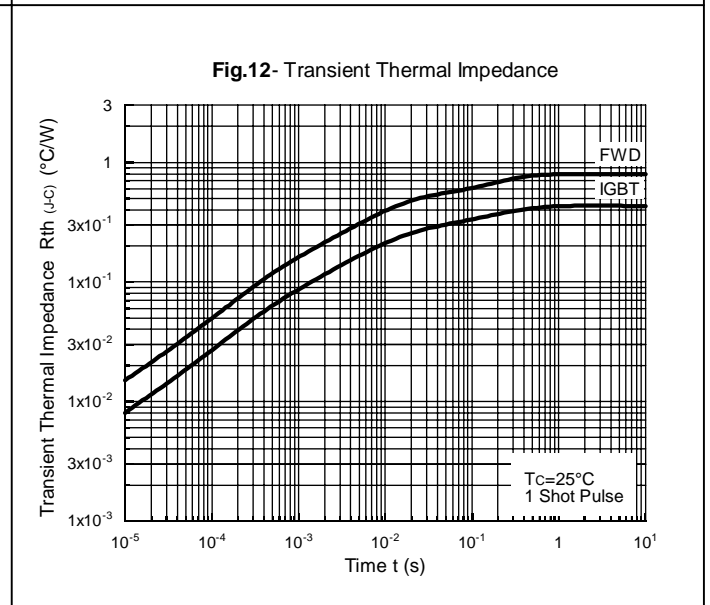
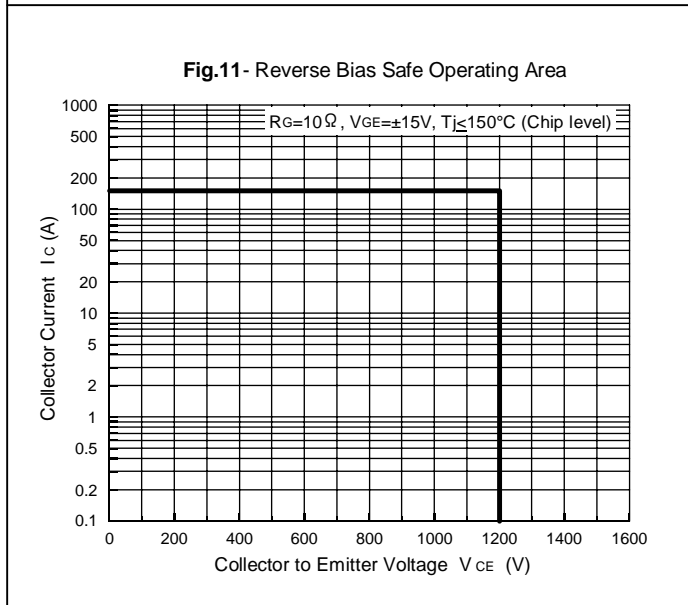
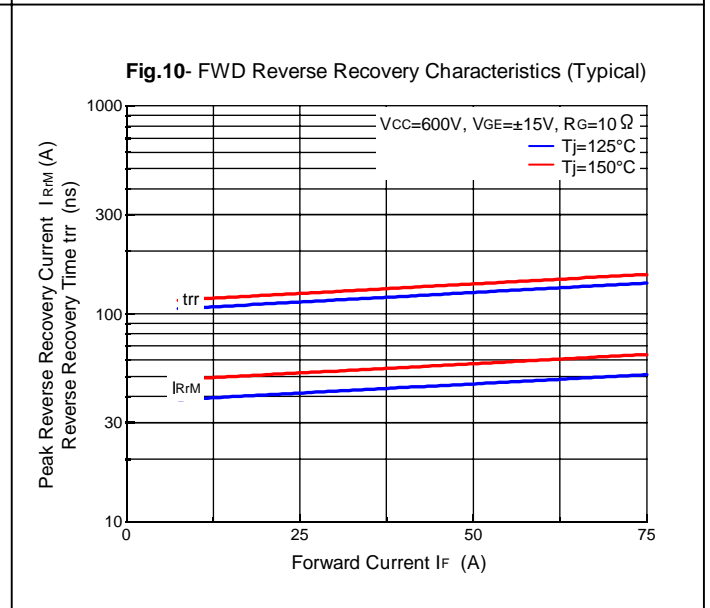
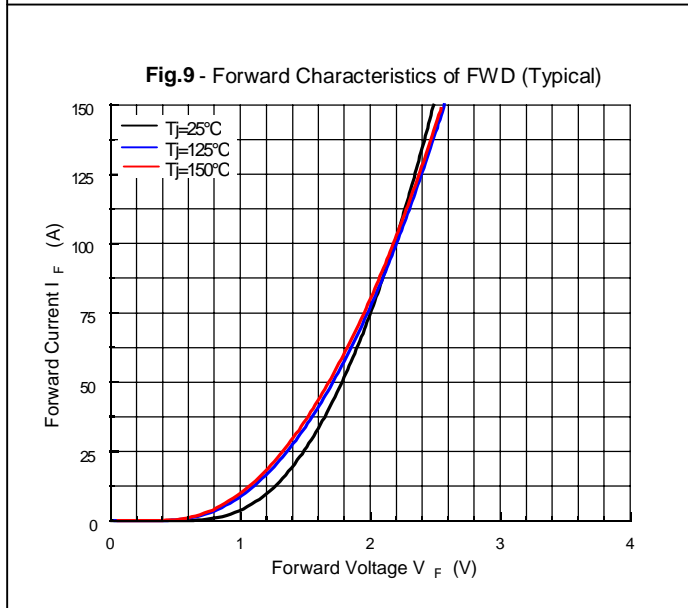
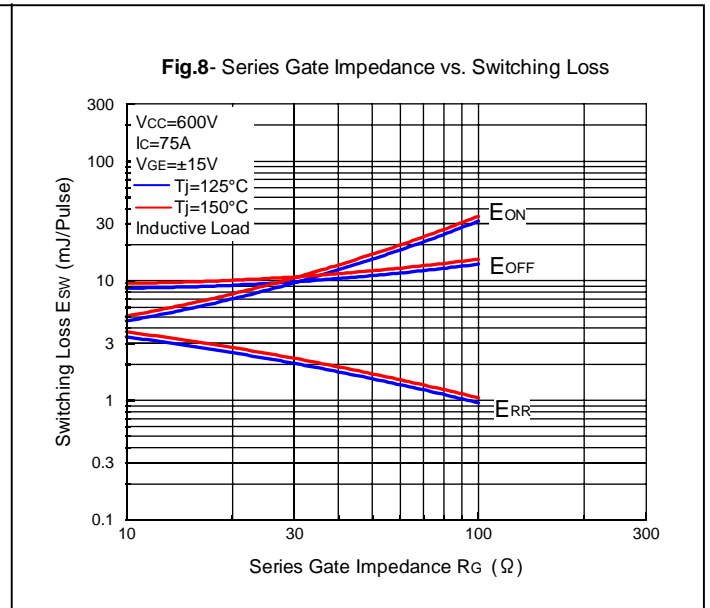
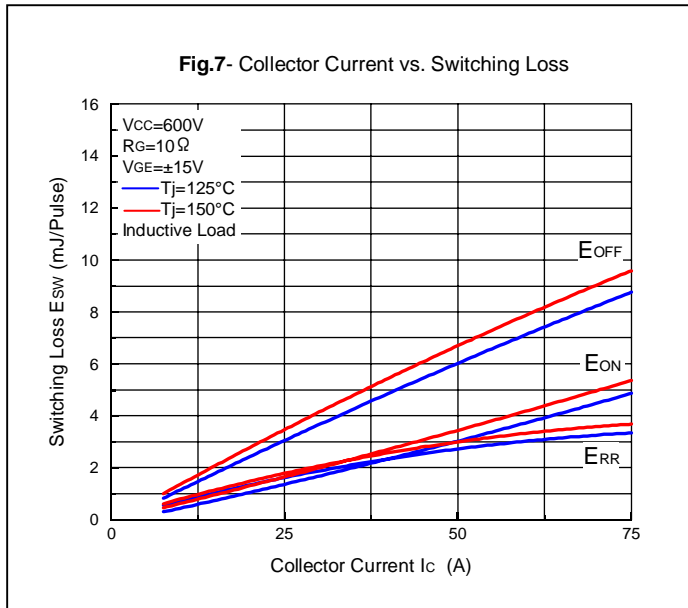

X-ON Electronics

Largest Supplier of Electrical and Electronic Components

Click to view similar products for [IGBT Modules category](#):

Click to view products by [Kyocera AVX manufacturer](#):

Other Similar products are found below :

[F3L400R07ME4_B22](#) [F3L400R12PT4_B26](#) [FB20R06W1E3_B11](#) [FD300R12KE3](#) [FD300R12KS4_B5](#) [FD400R12KE3](#) [FF100R12KS4](#)
[FF150R12KE3G](#) [FF200R06KE3](#) [FF200R06YE3](#) [FF300R06KE3_B2](#) [FF600R12IP4V](#) [FF800R17KP4_B2](#) [FF900R12IE4V](#)
[FP06R12W1T4_B3](#) [FP100R07N3E4](#) [FP100R07N3E4_B11](#) [FP10R06W1E3_B11](#) [FP10R12W1T4_B11](#) [FP10R12YT3](#) [FP15R12W2T4](#)
[FP15R12YT3](#) [FP20R06W1E3](#) [FP30R06W1E3](#) [FP40R12KT3G](#) [FP75R06KE3](#) [FS10R12YE3](#) [FS150R07PE4](#) [FS150R12PT4](#)
[FS150R17N3E4_B11](#) [FS20R06W1E3_B11](#) [FS30R06W1E3_B11](#) [FS75R12KE3G](#) [FS75R12W2T4_B11](#) [FZ1600R17HP4_B2](#)
[FZ300R12KE3G](#) [FZ400R17KE3](#) [FZ400R17KE4](#) [FZ600R65KE3](#) [DF1000R17IE4D_B2](#) [APTGT75DA60T1G](#) [DZ800S17K3](#) [F12-](#)
[25R12KT4G](#) [F3L200R12W2H3_B11](#) [F3L300R12ME4_B22](#) [F3L75R07W2E3_B11](#) [F4-150R12KS4](#) [F475R07W1H3B11ABOMA1](#)
[FD1400R12IP4D](#) [FD400R12KE3_B5](#)